

SMARTCAP®

BYD SHARK (0100)

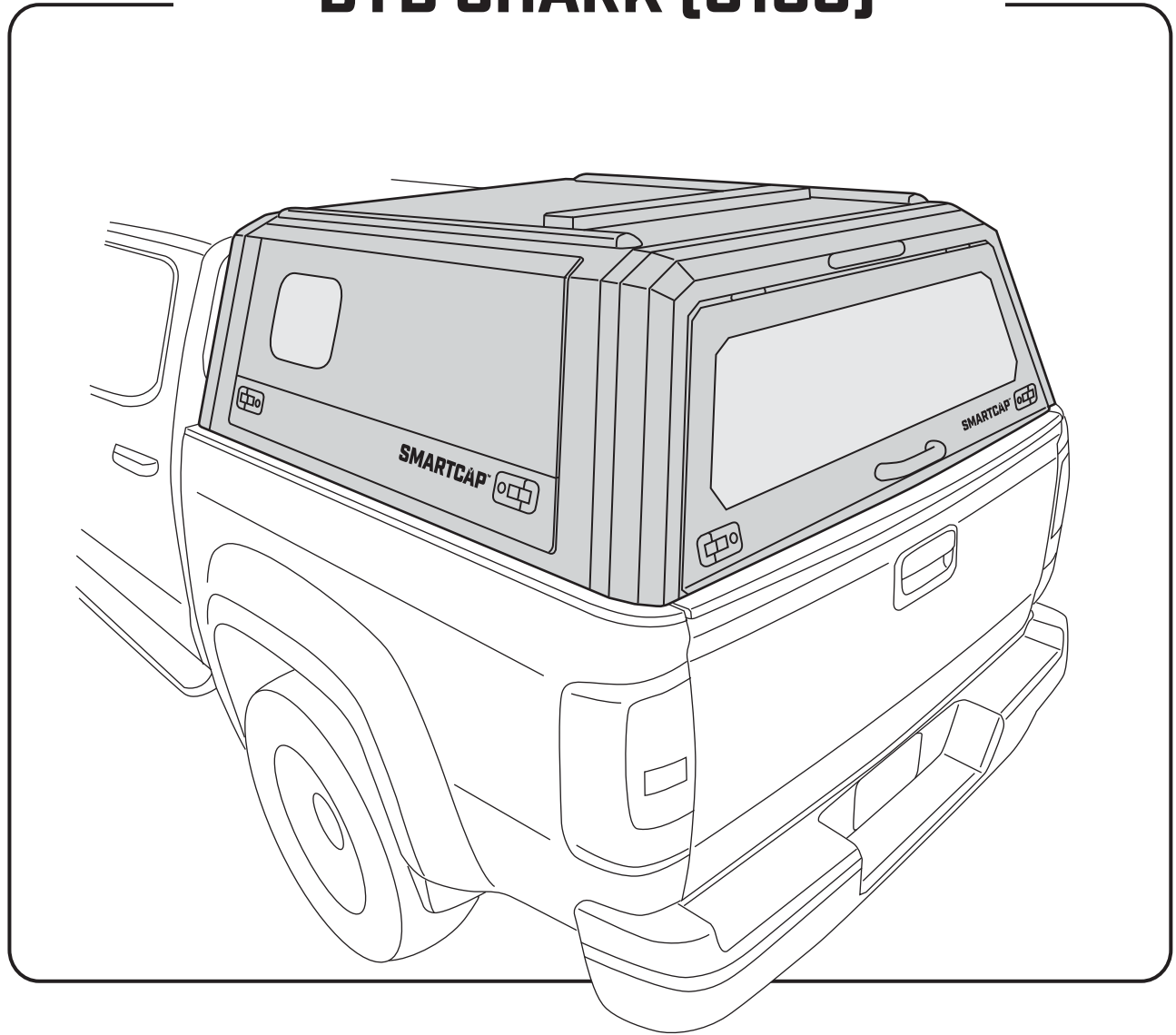

- ▼ **PREPARE A CLEAN WORK AREA.**
- ▼ **WE RECOMMEND A MINIMUM OF 2 PEOPLE FOR ASSEMBLY.**
- ▼ **ENSURE THE REQUIRED TOOLS ARE PRESENT AND ALL HARDWARE CONTENTS ARE ACCOUNTED FOR.**
- ▼ **NEVER USE ACETONE OR THINNERS ON PAINTED PARTS.**
- ▼ **READ THROUGH THE ENTIRE INSTRUCTION GUIDE BEFORE STARTING THIS PROCEDURE AND FOLLOW THE STEPS CAREFULLY TO AVOID ANY DAMAGE TO THE COMPONENTS OR THE VEHICLE.**

SMARTCAP.COM

SUPPORT.SA@SMARTCAP.COM - REST OF WORLD



TOOLS REQUIRED

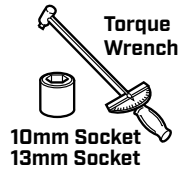
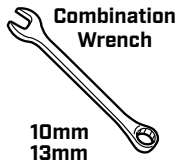
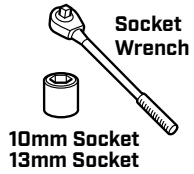

LAND CRUISER ONLY



IMPORTANT

- ▼ USE ONLY THE TOOLS RECOMMENDED ABOVE.
- ▼ USE ONLY THE HARDWARE PROVIDED IN THIS KIT.
- ▼ ASSISTANCE WILL BE NEEDED FOR THIS INSTALLATION.
FOUR PEOPLE ARE RECOMMENDED TO LIFT THE SMARTCAP ONTO THE VEHICLE.
- ▼ AVOID PINCHING OR CRUSHING HANDS AND FINGERS.
- ▼ INSPECT ALL KIT COMPONENTS FOR DAMAGE BEFORE ASSEMBLY.
- ▼ NEVER USE ACETONE OR THINNERS ON PAINTED PARTS.

COMPONENTS

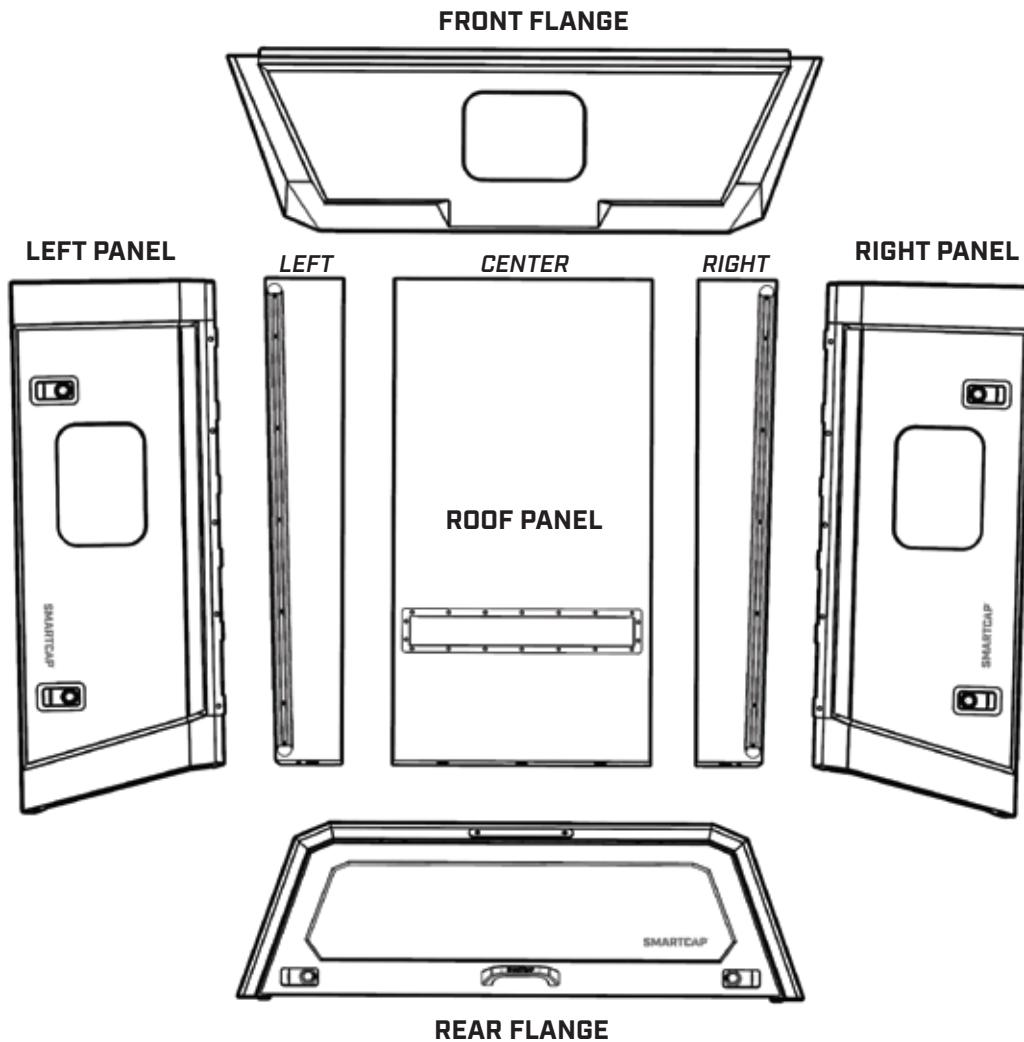

ASSEMBLY HARDWARE

FITMENT KIT

M6 BOLT

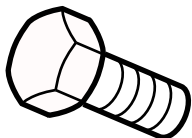

42X

**FASTENER
BLOCK CLAMP**

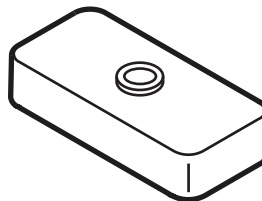

42X

**M6 LOCK
WASHER**



42X

**FASTENER
BLOCK**

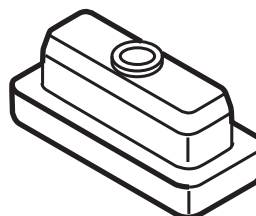

42X

D - RUBBER



1X

SPARE PARTS

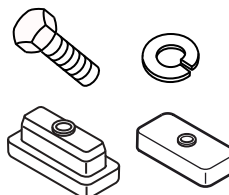

2X

PRE-FASTENED TO ROOF PANEL

**M6 FENDER
WASHER**



12X

SHORT BED

14X

STANDARD BED

**M6 LOCK
NUT**



12X

SHORT BED

14X

STANDARD BED

STEP 1



IMPORTANT

BE SURE TO REMOVE ALL SEVEN PANELS FROM THEIR PACKAGING AND INSPECT THE PAINTED SURFACES PRIOR TO ASSEMBLY, AS SMARTCAP WILL NOT ACCEPT WARRANTY CLAIMS AFTER ASSEMBLY IS COMPLETED. IF MANUFACTURING IMPERFECTIONS OR SHIPPING DAMAGES ARE FOUND, DO NOT CONTINUE WITH THE ASSEMBLY PROCESS AND CONTACT SUPPORT.SA@SMARTCAP.COM.

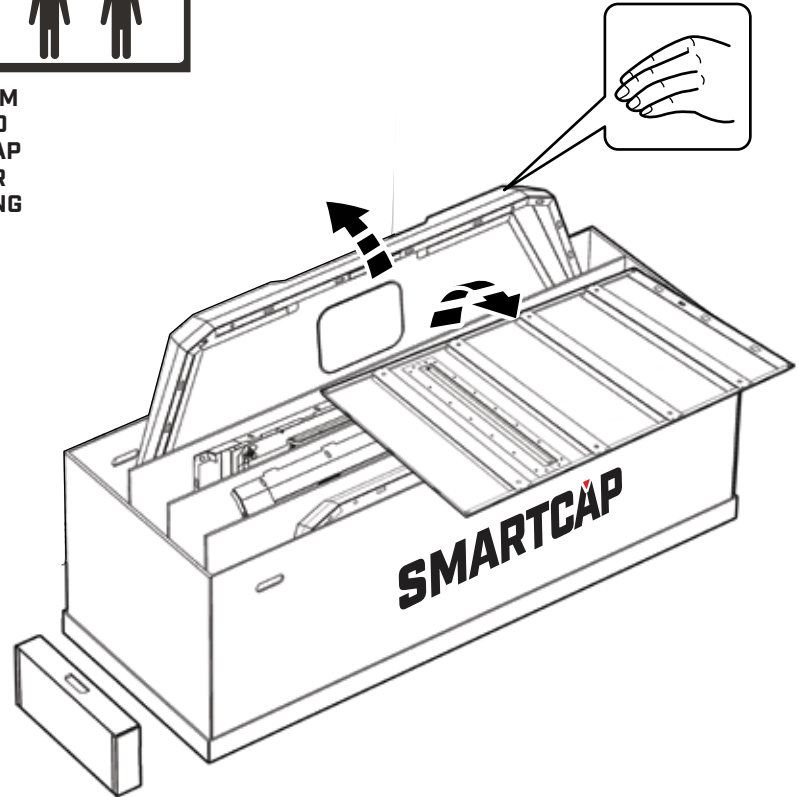

STEP 2

REMOVE THE FOUR CORNER STIFFENERS AND ONE OF THE CARDBOARD DIVIDERS TO BE USED AS A PROTECTIVE SURFACE DURING ASSEMBLY.

UNFOLD THE CARDBOARD DIVIDER AND PLACE IT WHERE YOU PLAN TO ASSEMBLE YOUR CAP.

PLACE THE FOUR CORNER STIFFENERS AS SHOWN BELOW.

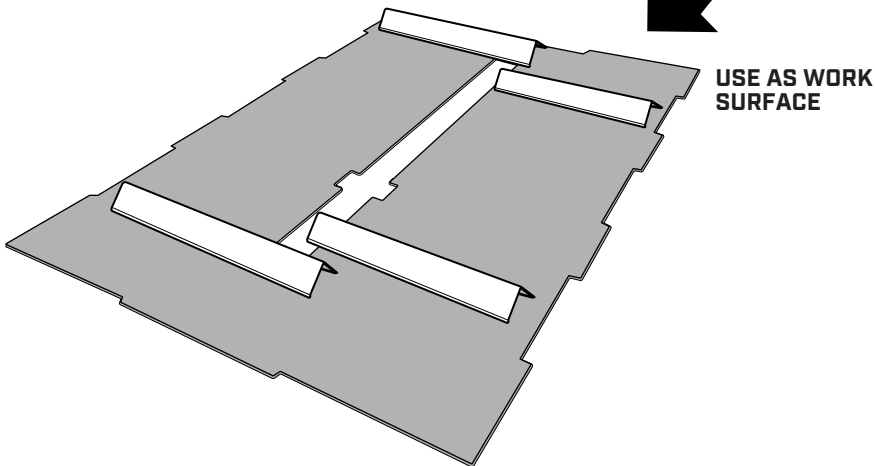
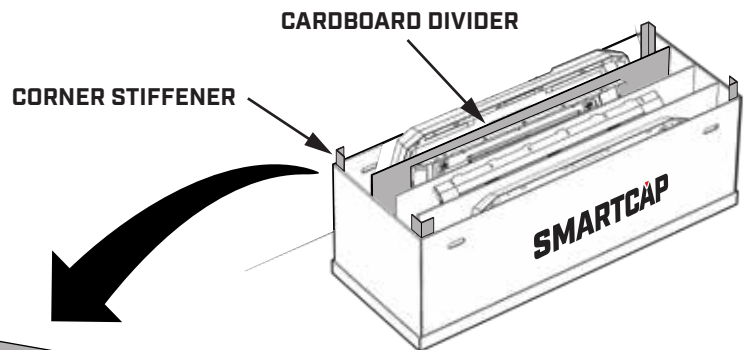

STEP 3

PLACE THE ROOF PANELS ON TOP OF THE CORNER STIFFENERS, WITH THE BOTTOM OF THE ROOF PANELS FACING UP.

ALIGN THE PANELS SO THAT THE PROFILE OF THE FRONT AND REAR EDGES MATCH.

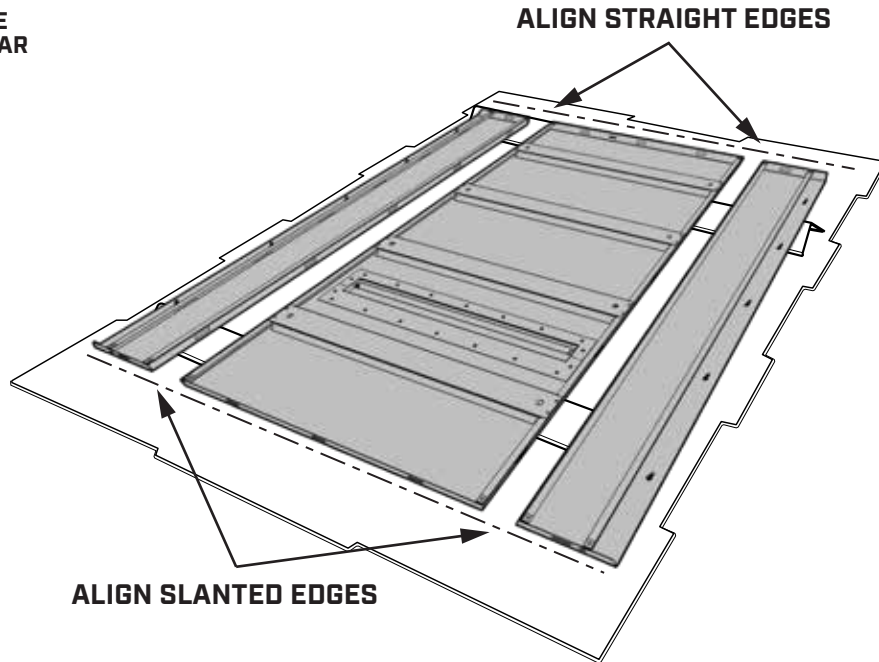

STEP 4

ASSEMBLE THE FASTENER BLOCKS TO THE ROOF PANELS USING A TORQUE WRENCH AND 10MM SOCKET TO 3.7 FT. LBS [5 NEWTON METERS].

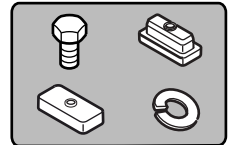

MAKE SURE ROOF PANELS ARE LEVEL

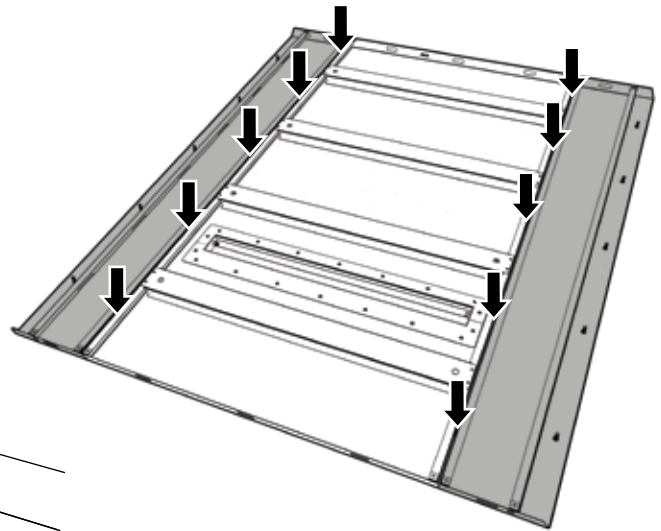

12X SHORT BED

14X STANDARD BED

10mm



M6 BOLT

BLOCK CLAMP

M6 LOCK WASHER

FASTENER BLOCK

[3.7 ft. lbs]/[5 Nm]

STEP 5

USE A 10MM COMBINATION WRENCH TO REMOVE THE LOCK NUTS AND FENDER WASHERS FROM THE ROOF BOLTS AND SAVE FOR REUSE.



AIR VENT INDICATES REAR OF CANOPY

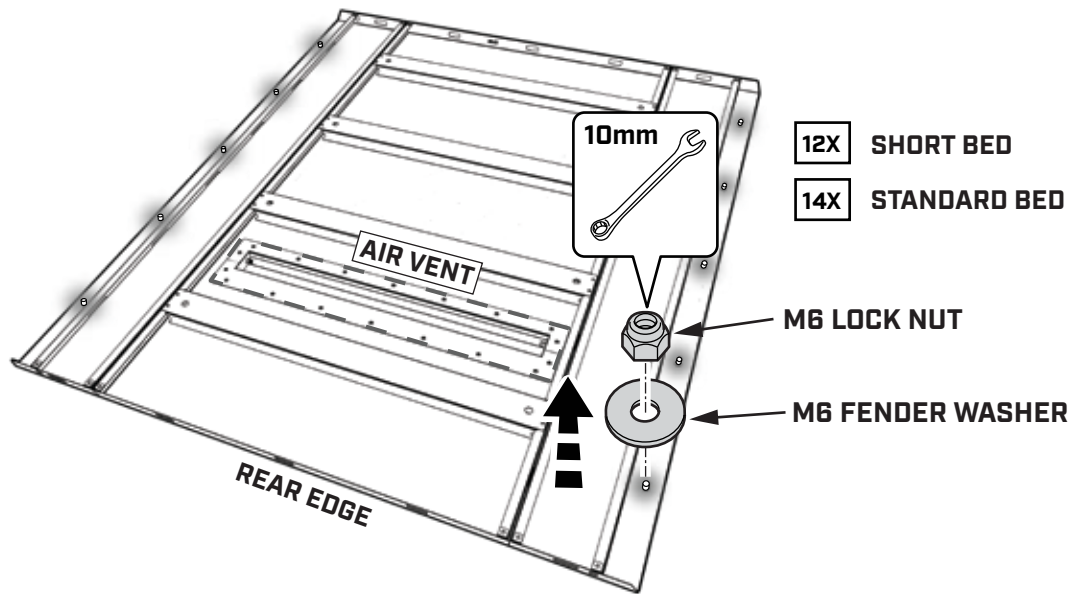

STEP 6

RETRIEVE THE FASTENER BLOCKS FROM THE FITMENT KIT AND PLACE 15 ON EACH SIDE OF THE ROOF PANEL.

TAKE APART THE FASTENER BLOCKS SO THEY ARE READY TO USE DURING ASSEMBLY.

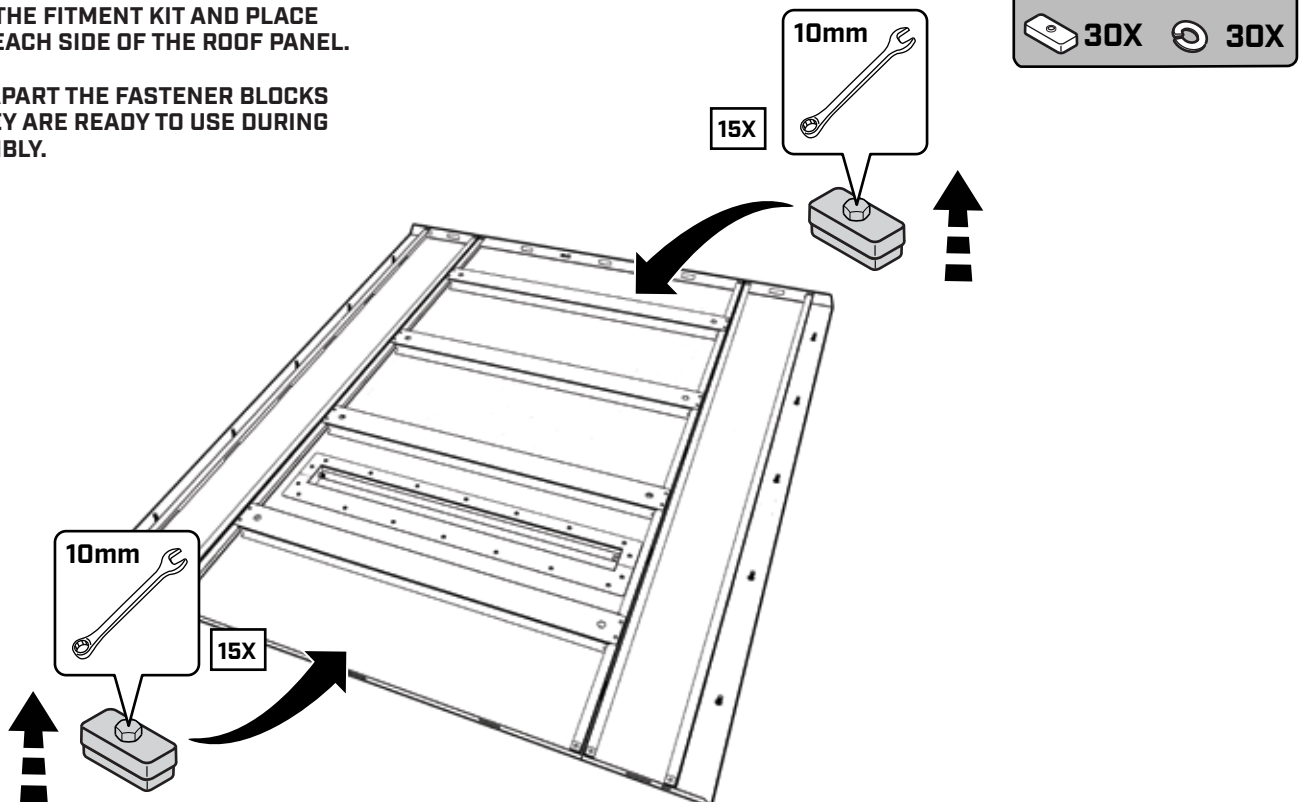

STEP 7

LOCATE THE RIGHT PANEL IN THE SMARTCAP PACKAGE AND BRING IT TO YOUR WORK AREA.



SLANTED EDGE INDICATES REAR OF CANOPY

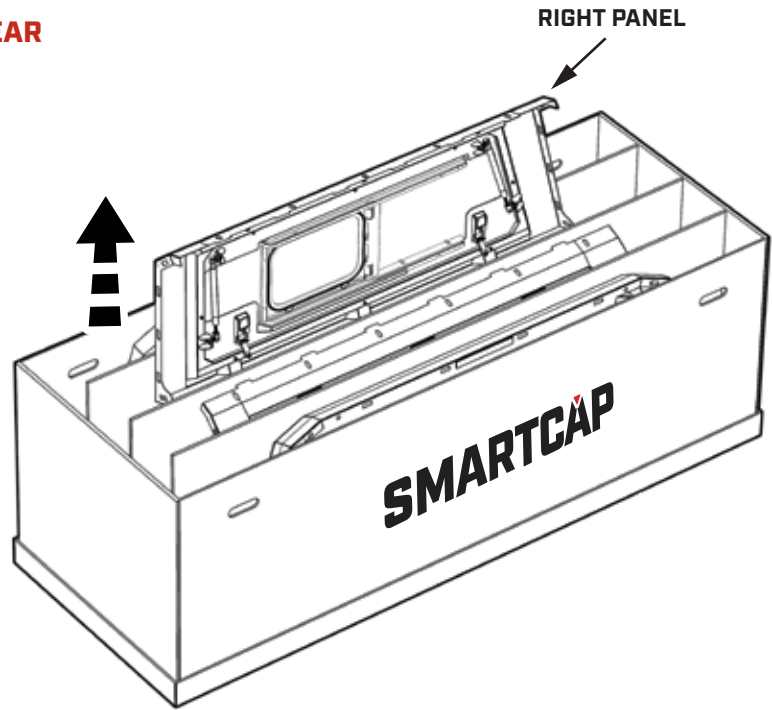

STEP 8

INSERT PANEL TABS INTO THE NARROW SLOTS JUST ABOVE FOAM PADDING ON ROOF PANEL.



TAP FIRMLY WITH PALM OF HAND UNTIL THERE IS A 2-3MM GAP.

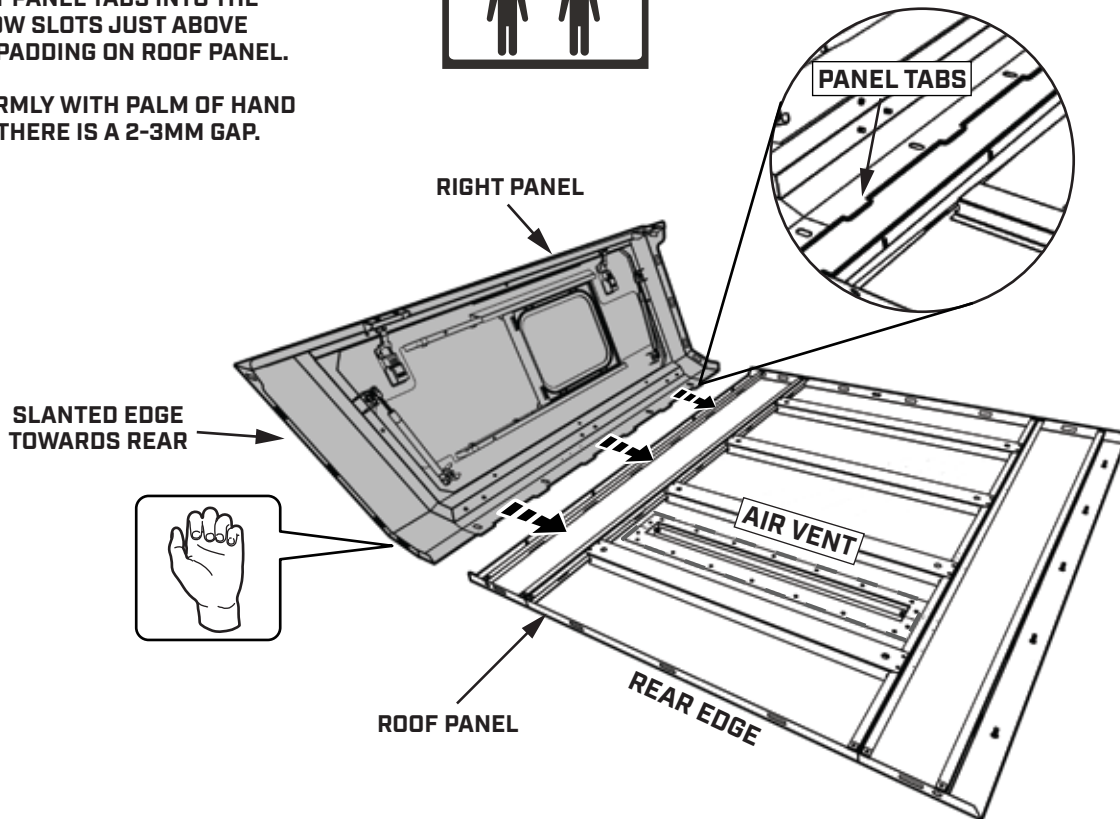

STEP 9

HAND TIGHTEN M6 LOCK NUT WITH M6 FENDER WASHER TO ALL BOLTS.

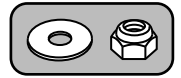

SUPPORT RIGHT PANEL UNTIL ASSEMBLED TO FRONT FLANGE

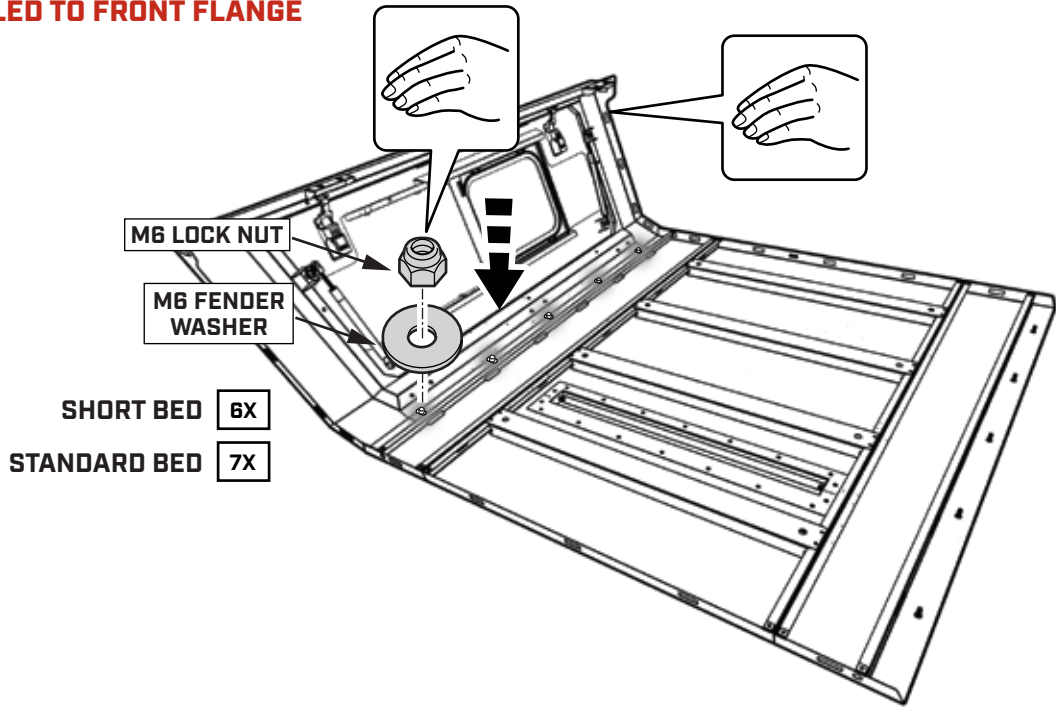

STEP 10

LOCATE THE FRONT FLANGE IN THE SMARTCAP PACKAGE AND BRING IT TO YOUR WORK AREA.

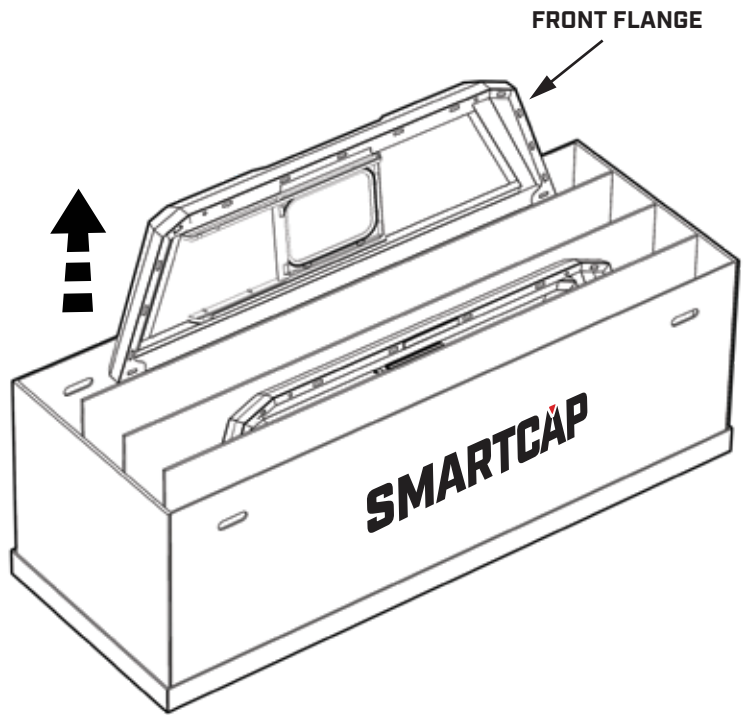

STEP 11

PLACE FRONT FLANGE AS SHOWN BELOW.

HAND TIGHTEN TWO FASTENER BLOCKS AT THE INDICATED LOCATIONS TO SUPPORT THE RIGHT PANEL AND FRONT FLANGE.

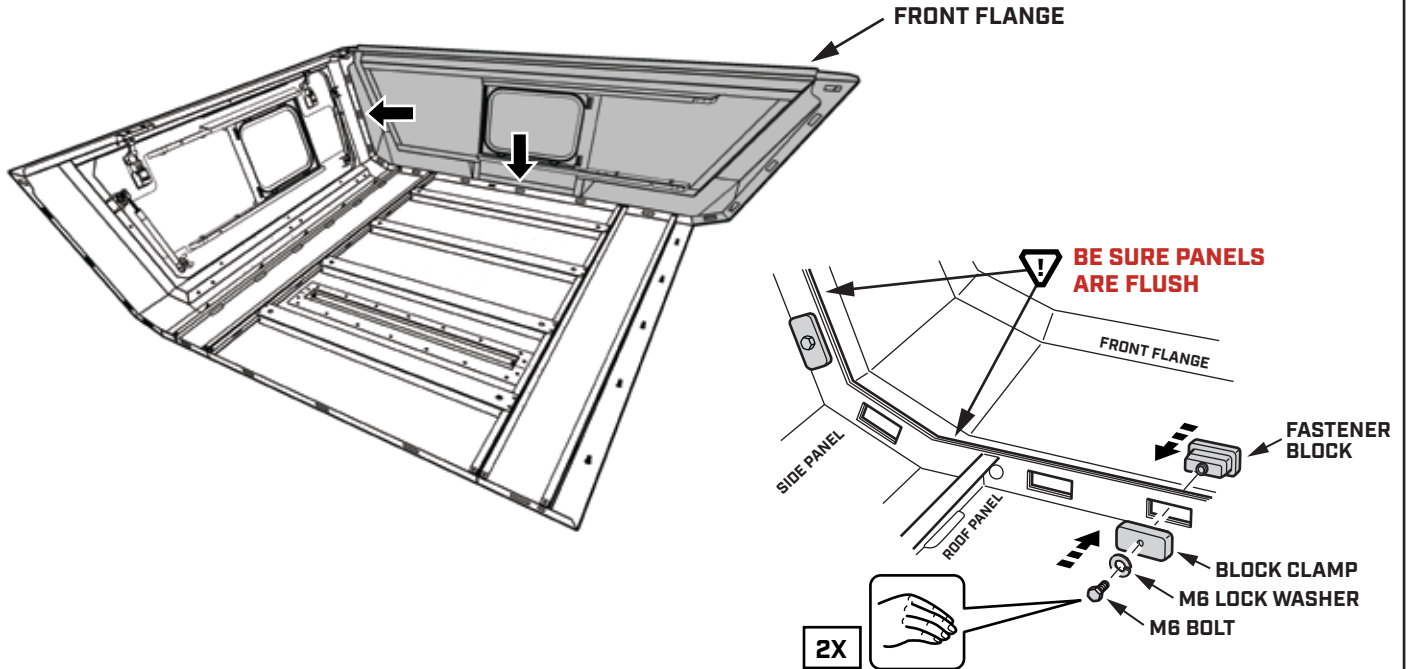

STEP 12

LOCATE THE LEFT PANEL IN THE SMARTCAP PACKAGE AND BRING IT TO YOUR WORK AREA.



SLANTED EDGE INDICATES REAR

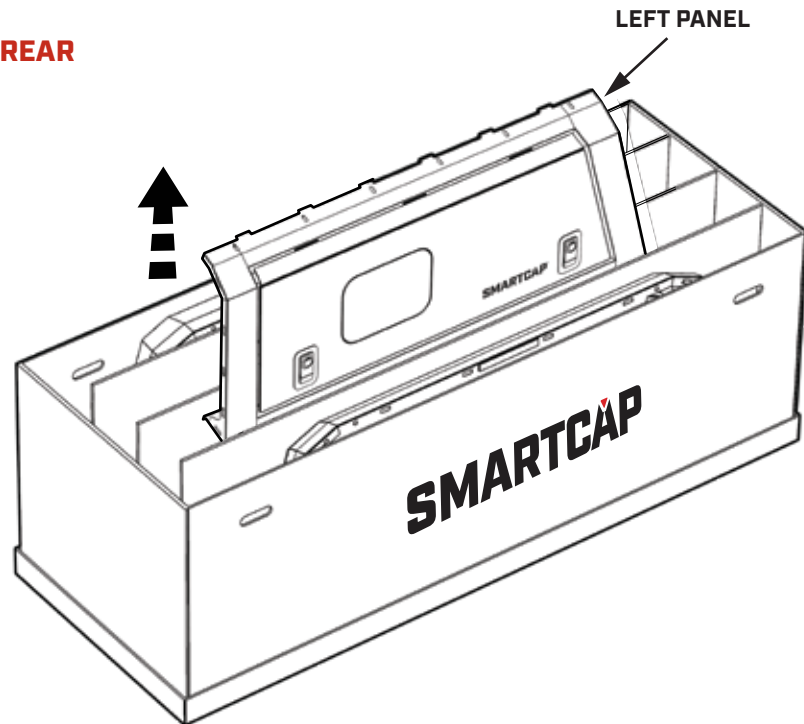

STEP 13

INSERT PANEL TABS INTO THE NARROW SLOTS JUST ABOVE FOAM PADDING ON ROOF PANEL.

TAP FIRMLY WITH PALM OF HAND UNTIL THERE IS A 2-3MM GAP.

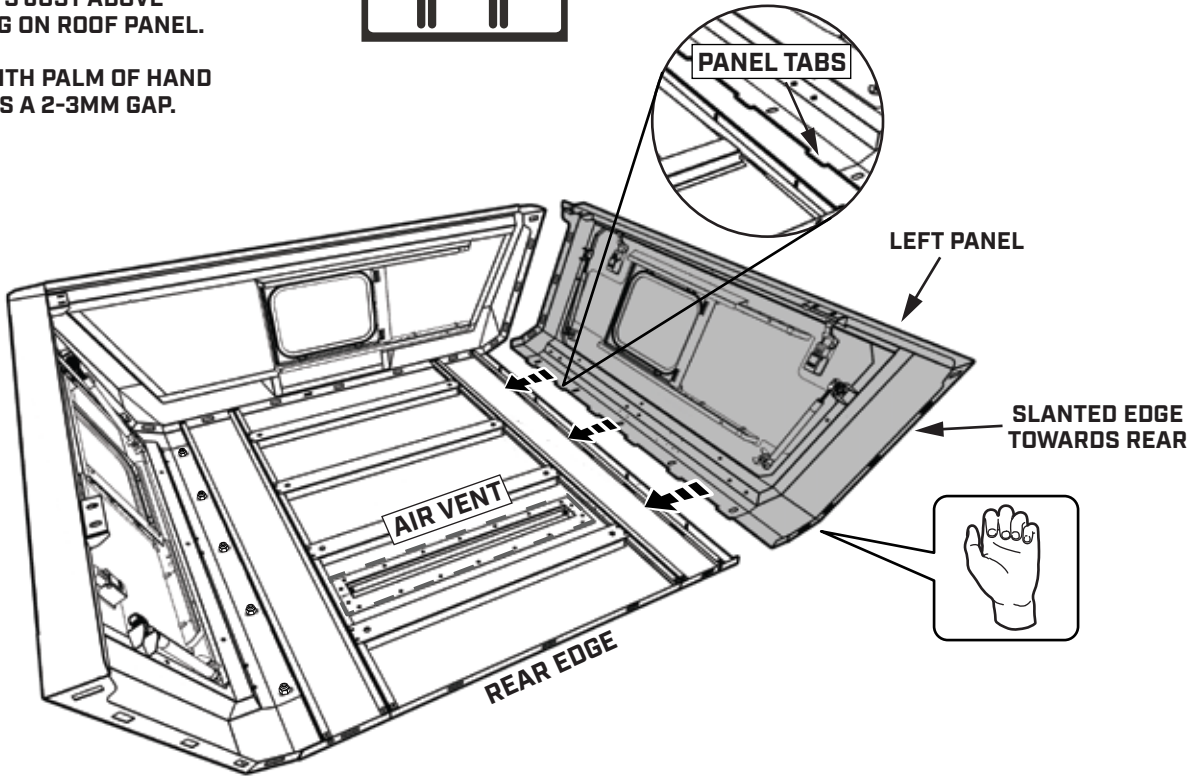

STEP 14

HAND TIGHTEN M6 LOCK NUT WITH M6 FENDER WASHER TO ALL BOLTS.

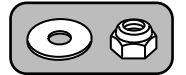

 **SUPPORT LEFT PANEL UNTIL ASSEMBLED TO FRONT FLANGE**

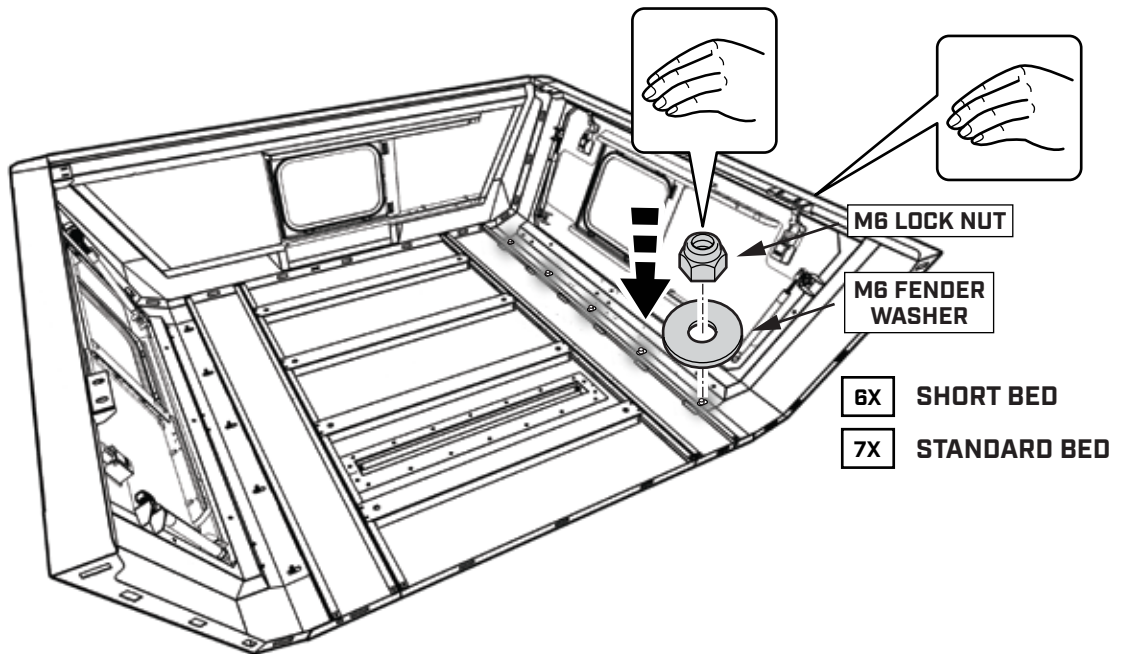

STEP 15

INSTALL HARDWARE ALONG FRONT FLANGE WITH BOLT ON INSIDE.

START AT CENTER OF THE FRONT FLANGE AND WORK YOUR WAY OUTWARDS.

ADJUST LEFT AND RIGHT PANELS TO ALIGN THE FASTENER BLOCK HOLES.

HAND TIGHTEN ONLY.

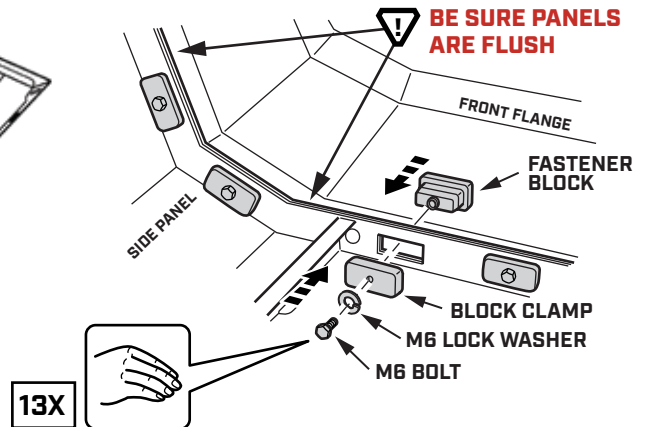
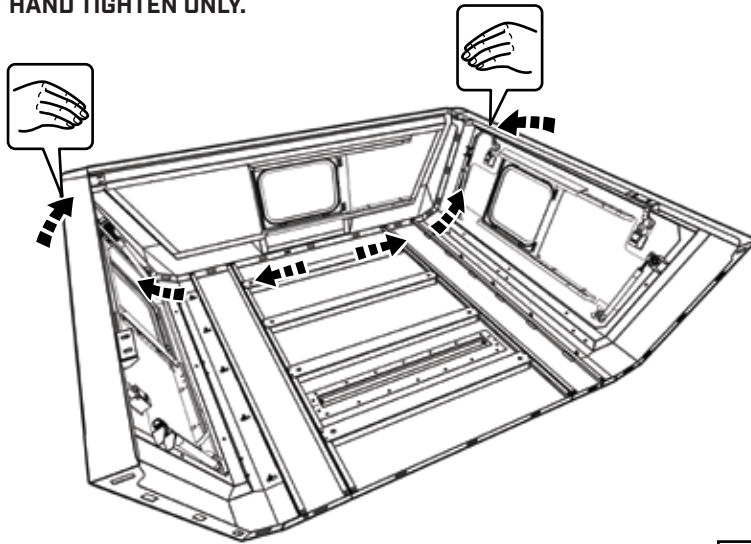

STEP 16

LOCATE THE REAR FLANGE IN THE SMARTCAP PACKAGE AND BRING IT TO YOUR WORK AREA.

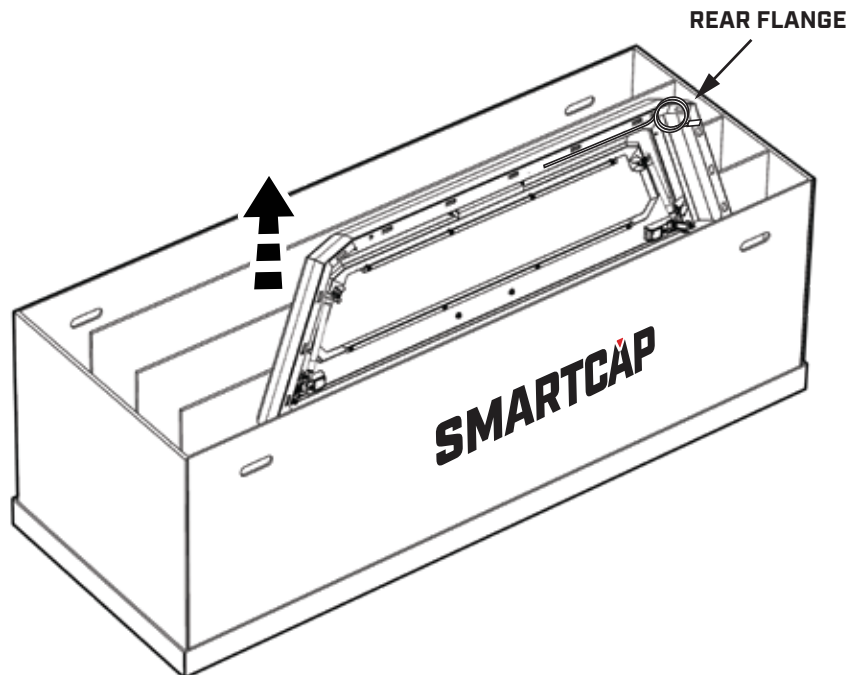

STEP 17

PLACE REAR FLANGE AS SHOWN BELOW.

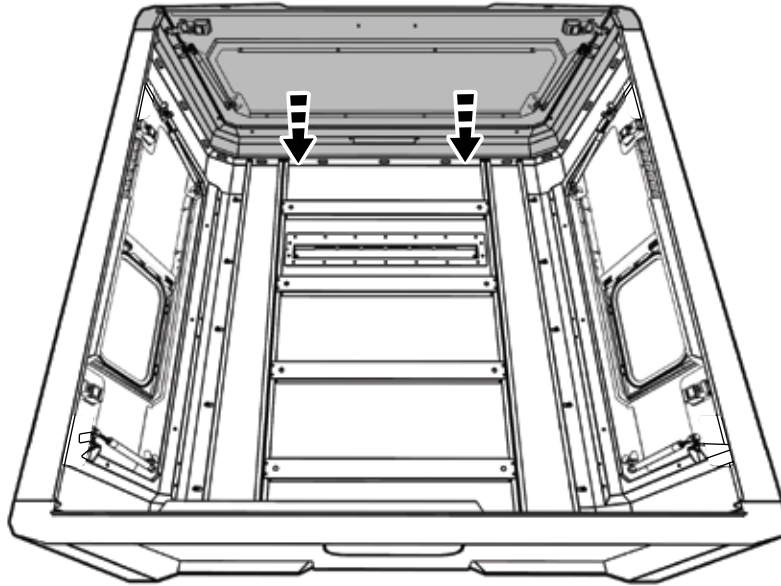

STEP 18

INSTALL HARDWARE ALONG REAR FLANGE WITH BOLT ON INSIDE.



START AT CENTER OF THE REAR FLANGE AND WORK YOUR WAY OUTWARDS.

ADJUST LEFT AND RIGHT PANELS TO ALIGN THE FASTENER BLOCK HOLES.

HAND TIGHTEN ONLY.

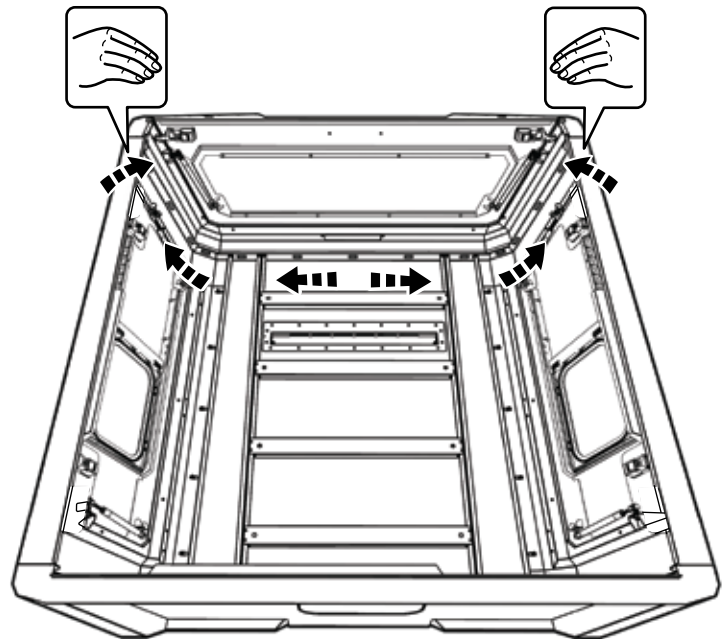
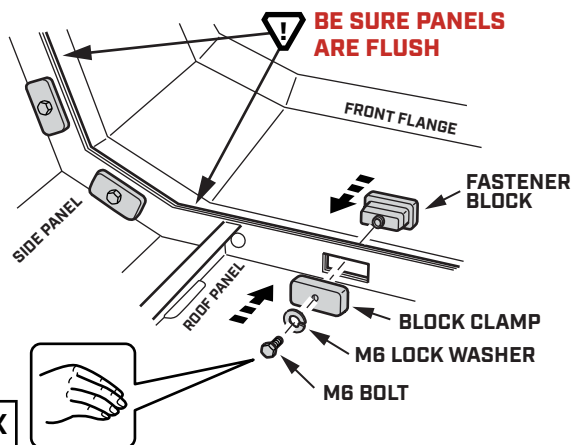

STEP 19

TIGHTEN ALL HARDWARE WITH TORQUE WRENCH
AND 10MM SOCKET TO 3.7 FT. LBS. (5 NEWTON METERS)

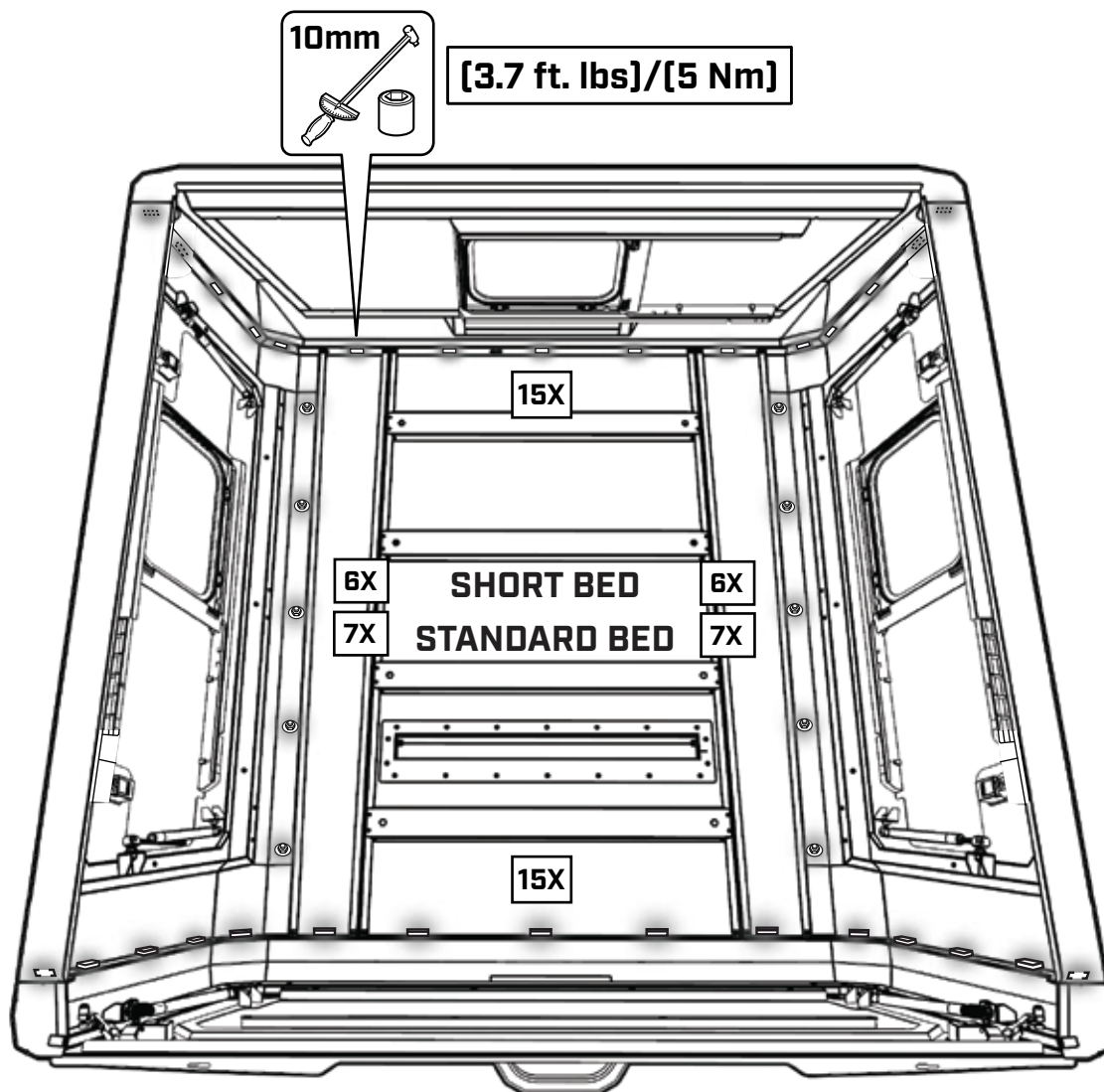

STEP 20

ENSURE THE ENTIRE BOTTOM EDGE OF THE SMARTCAP IS CLEAN.

LOCATE BOTH RETENTION TABS ON THE REAR FLANGE AND BEND EACH TO A 45-DEGREE ANGLE FOR D-RUBBER FITMENT.

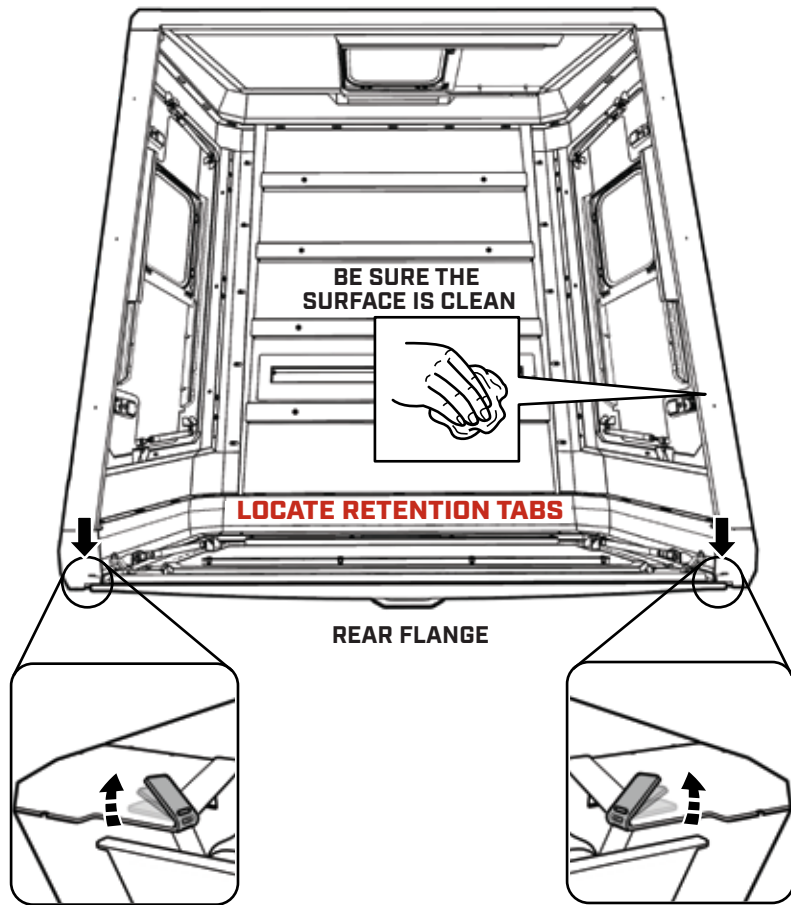

STEP 21

TRIM THE D-RUBBER WITH A CLEAN, STRAIGHT CUT.

APPLY 2-3 INCHES SUPER GLUE NEAR THE RETENTION TABS, ALONG THE BOTTOM EDGE OF THE REAR FLANGE

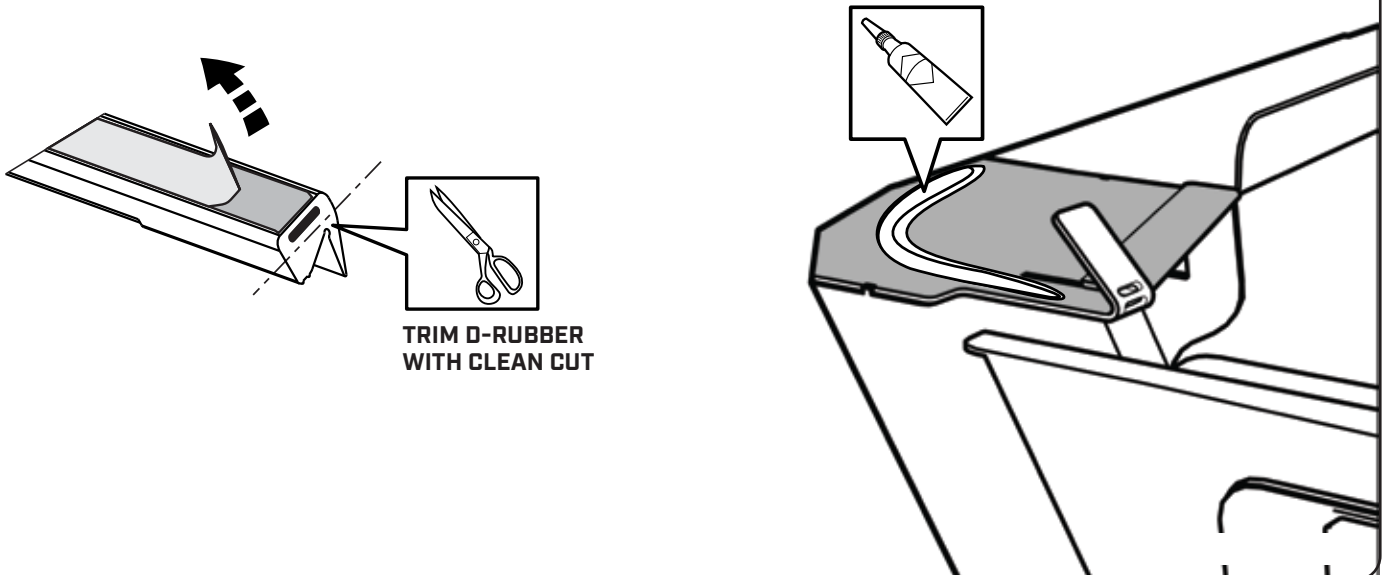
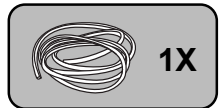

STEP 22

FULLY INSERT THE RETENTION TAB INTO THE SLOT ON THE D-RUBBER. ENSURE THE D-RUBBER IS ORIENTED CORRECTLY WITH ITS PROFILE MATCHING THE CONTOUR OF THE REAR FLANGE.

PRESS DOWN FIRMLY ON THE TAB AND THE D-RUBBER TO BOND IT TO THE REAR FLANGE, CREATING A TIGHT SEAL.

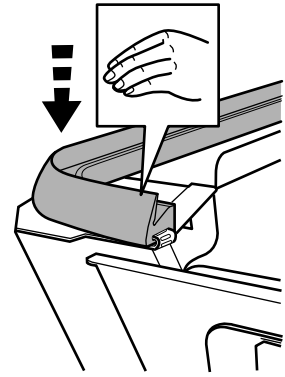
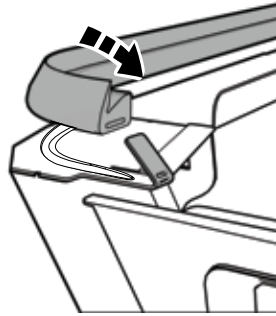

CORRECT D-RUBBER ORIENTATION

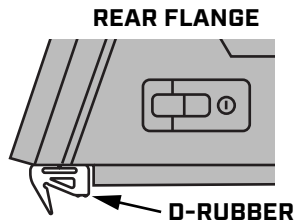

INCORRECT D-RUBBER ORIENTATION

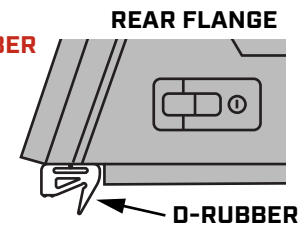

STEP 23

ALIGN THE D-RUBBER ALONG THE SMARTCAP'S EDGE, MAINTAINING A CONSISTENT 1/8 INCH GAP FROM THE EDGE.

START FROM ONE CORNER AND WORK YOUR WAY AROUND THE CAP TO ENSURE PROPER PLACEMENT AND ALIGNMENT.

REINFORCE CORNERS WITH SUPER GLUE.

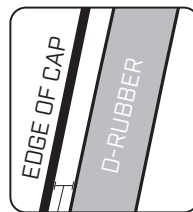

1/8 INCH FROM EDGE

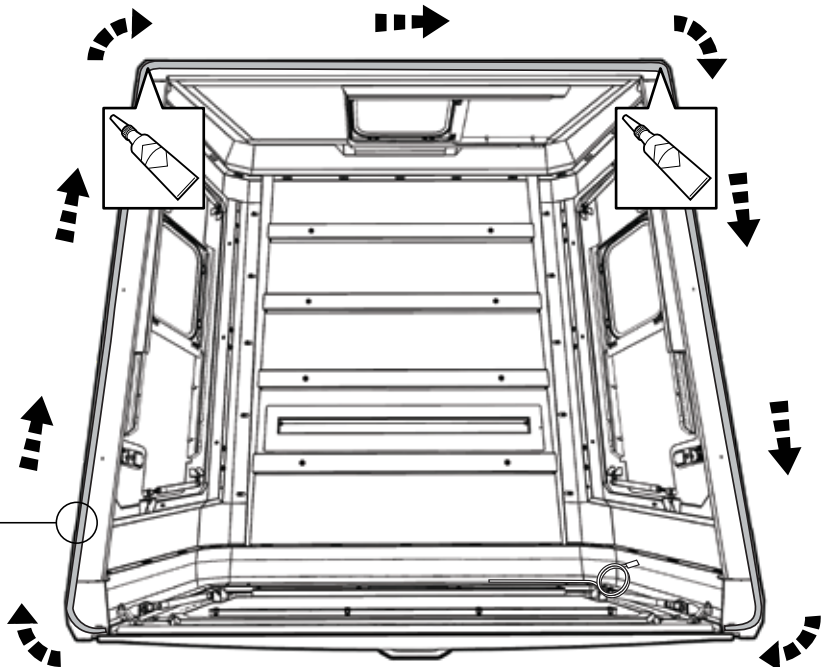

STEP 24

VERSION A

TRIM ANY EXCESS D-RUBBER BEYOND THE EDGE FOR A NEAT FINISH.

APPLY 2-3 INCHES OF SUPER GLUE NEAR THE RETENTION TAB, ALONG THE BOTTOM EDGE OF THE REAR FLANGE. FULLY INSERT THE RETENTION TAB INTO THE SLOT ON THE D-RUBBER.

PRESS DOWN FIRMLY ON THE TAB AND THE D-RUBBER TO BOND IT TO THE REAR FLANGE, CREATING A TIGHT SEAL.

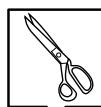

TRIM D-RUBBER WITH CLEAN CUT

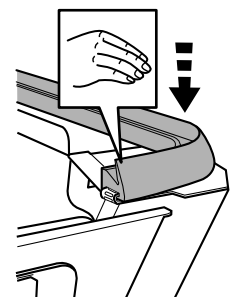
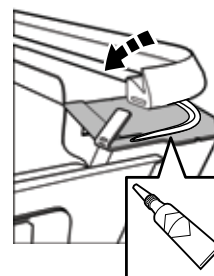
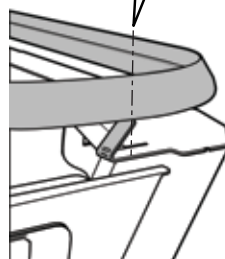

INSTALLATION HARDWARE AND TOOLS REQUIRED



M8 BOLT X 22



UTILITY KNIFE



M8 FENDER WASHER X 30



SCISSORS



M8 SPRING WASHER X 12

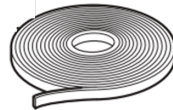

FOAM SEAL X 1



M8 LOCK NUT X 10

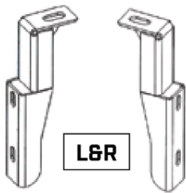

FRONT BRACKET
1 X LEFT SIDE
1 X RIGHT SIDE



2 X REAR BRACKET



SOCKET WRENCH
M10 SOCKET
M13 SOCKET



COMBINATION WRENCH



TORQUE WRENCH
M10 SOCKET
M13 SOCKET

STEP 25

INSPECT THE TRUCK BED. IF FRONT EDGE IS LOWER THAN THE SIDES, ADD FOAM SEAL TAPE TO THE FRONT EDGE OF THE BED.

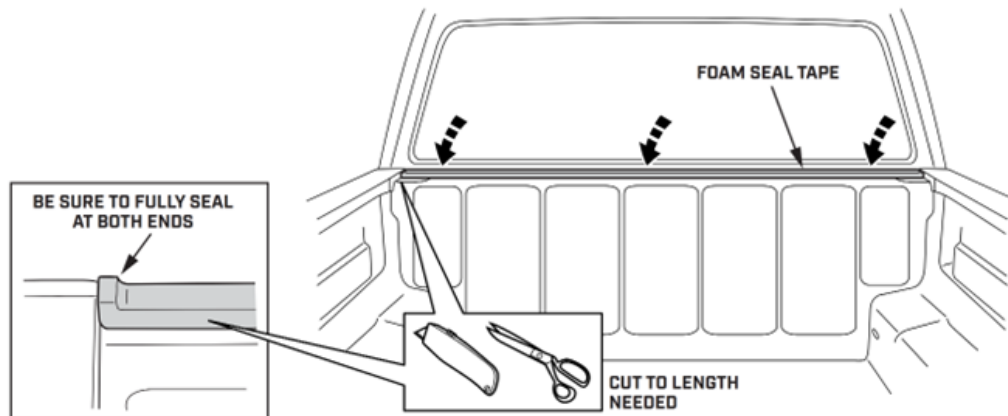
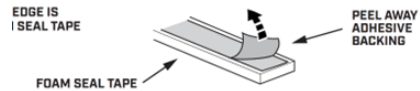

STEP 26

PLACE FRONT BRACKET AND FASTEN BOLTS BY HAND.

ENSURE TOP OF BRACKET MAX 13MM ABOVE TOP SILL OF BIN.

TIGHTEN BOLTS IN SET POSITION.

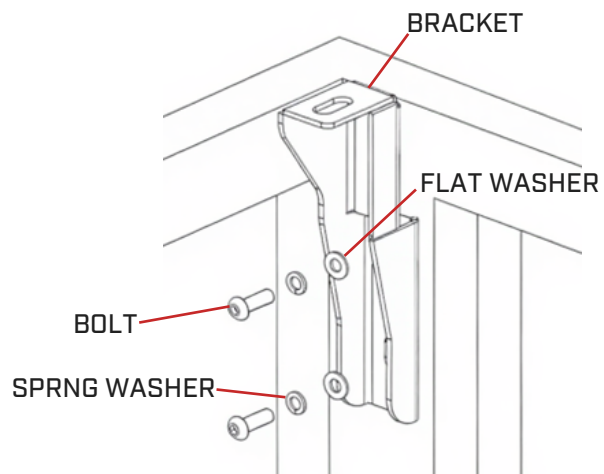

STEP 27

REMOVE THE REAR HARDWARE FROM THE INNER WALL OF THE TRUCK BED.

TIGHTEN BOTH REAR MOUNTING WITH M8 BOLT, M8 LOCK WASHER AND M8 FENDER WASHER AS SHOWN.

ADJUST REAR BRACKET HEIGHT FOR IMPROVED SEALING OF REAR DOOR TO TAILGATE.

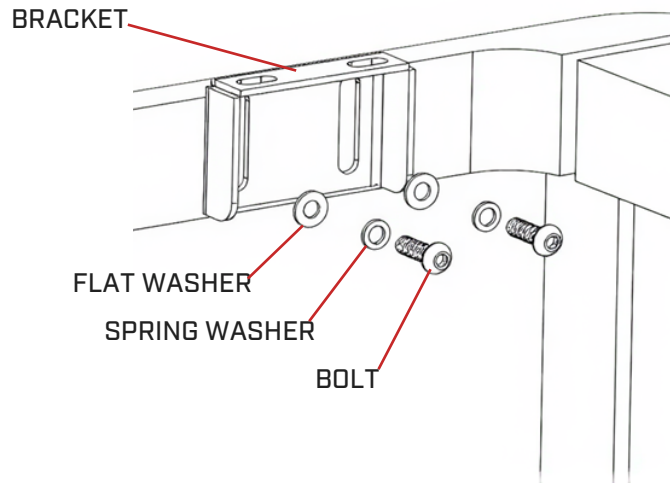

STEP 28

USE 4 PEOPLE TO LIFT THE ASSEMBLED SMARTCAP ONTO THE TRUCK BED.

TO AVOID DAMAGE TO THE D-RUBBER, DO NOT SLIDE THE SMARTCAP INTO PLACE.

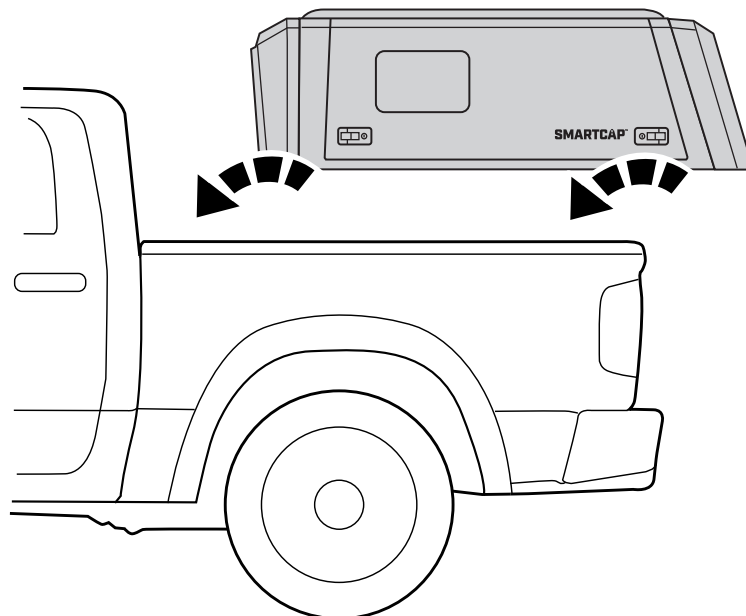

STEP 29



CHECK THAT THE SMARTCAP IS PROPERLY POSITIONED AND CENTERED ON THE TRUCK BED.

IT'S IMPORTANT THAT THE SMARTCAP IS NOT PUSHED TOO FAR FORWARD, LEAVING A GAP BETWEEN THE SMARTCAP AND THE CAB.

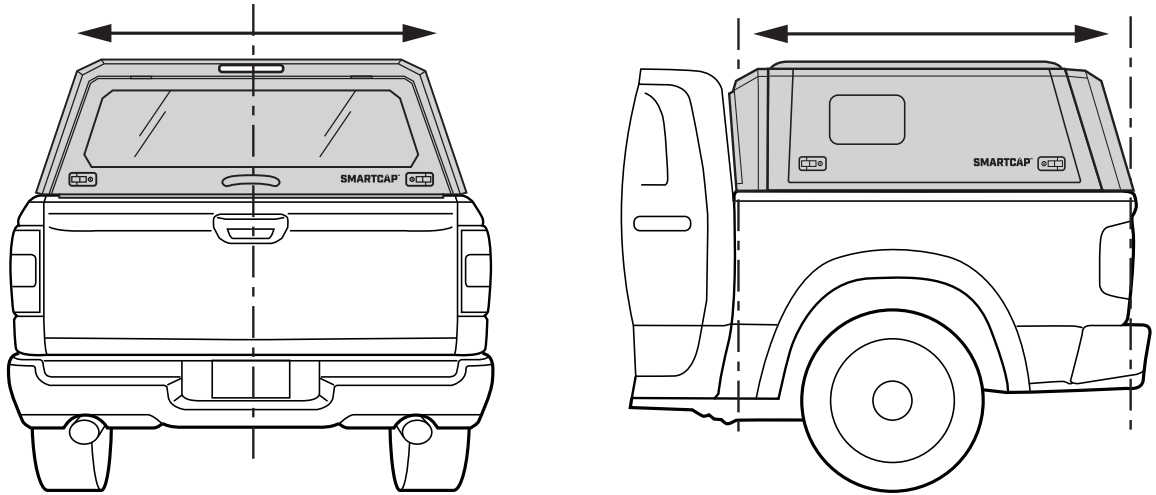

STEP 30

WALK AROUND THE TRUCK BED TO MAKE SURE THE D-RUBBER FITMENT IS CORRECT AND THAT THE RUBBER LIP IS PROPERLY TUCKED UNDERNEATH THE CAP.

CORRECT D-RUBBER ORIENTATION



D-RUBBER

REAR FLANGE

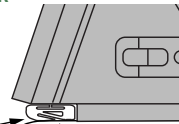

TAILGATE

INCORRECT D-RUBBER ORIENTATION



D-RUBBER

REAR FLANGE

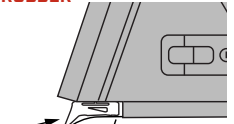

TAILGATE

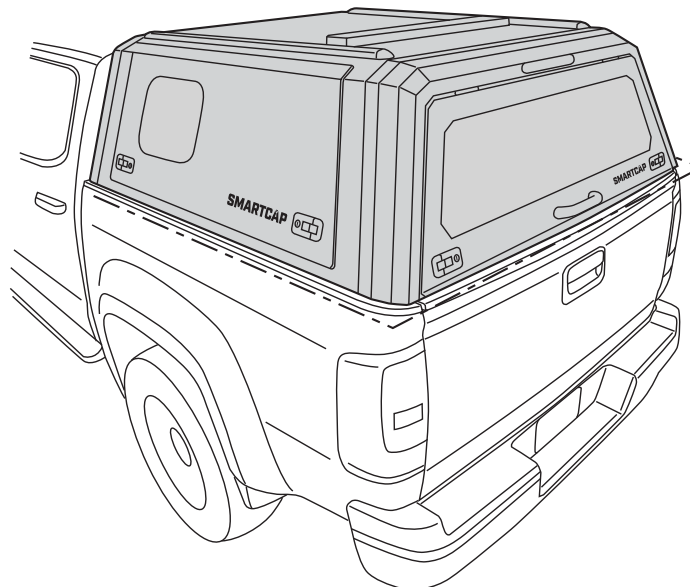

STEP 31

ONCE CANOPY POSITIONED, SECURE WITH HARDWARE PROVIDED AND TIGHTEN.

ENSURE FRONT SEALING OF CANOPY SUFFICIENT.

CHECK BIN CORNERS FOR ANY LEAK POINTS.

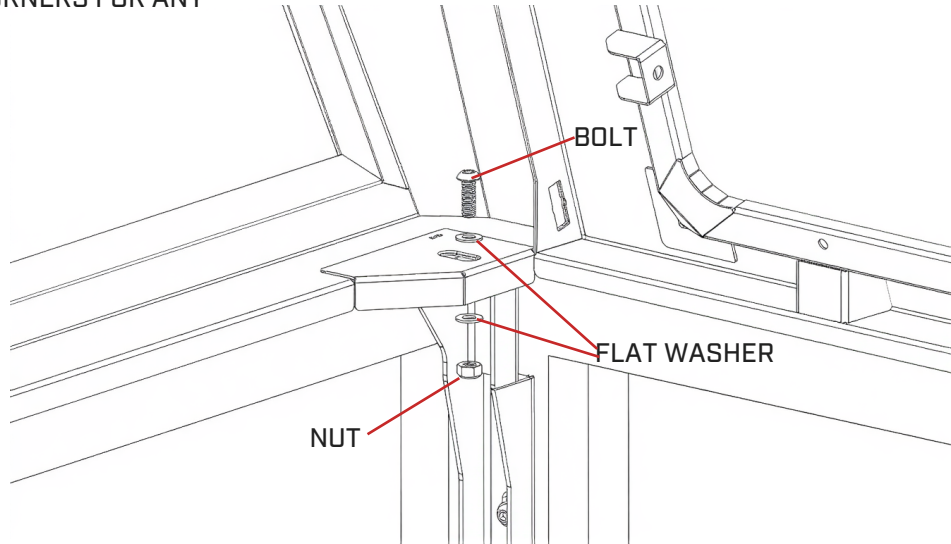

STEP 32

ONCE CANOPY POSITIONED, SECURE WITH HARDWARE PROVIDED AND TIGHTEN.

ENSURE FRONT SEALING OF CANOPY SUFFICIENT.

ADJUST REAR BRACKET HEIGHT TO ACHIEVE BEST SEALING POSITION.

