

**SMARTCAP®**

# **INSTRUCTION GUIDE**

## **TOYOTA TUNDRA**

### **2022-CURRENT (3rd Generation)**

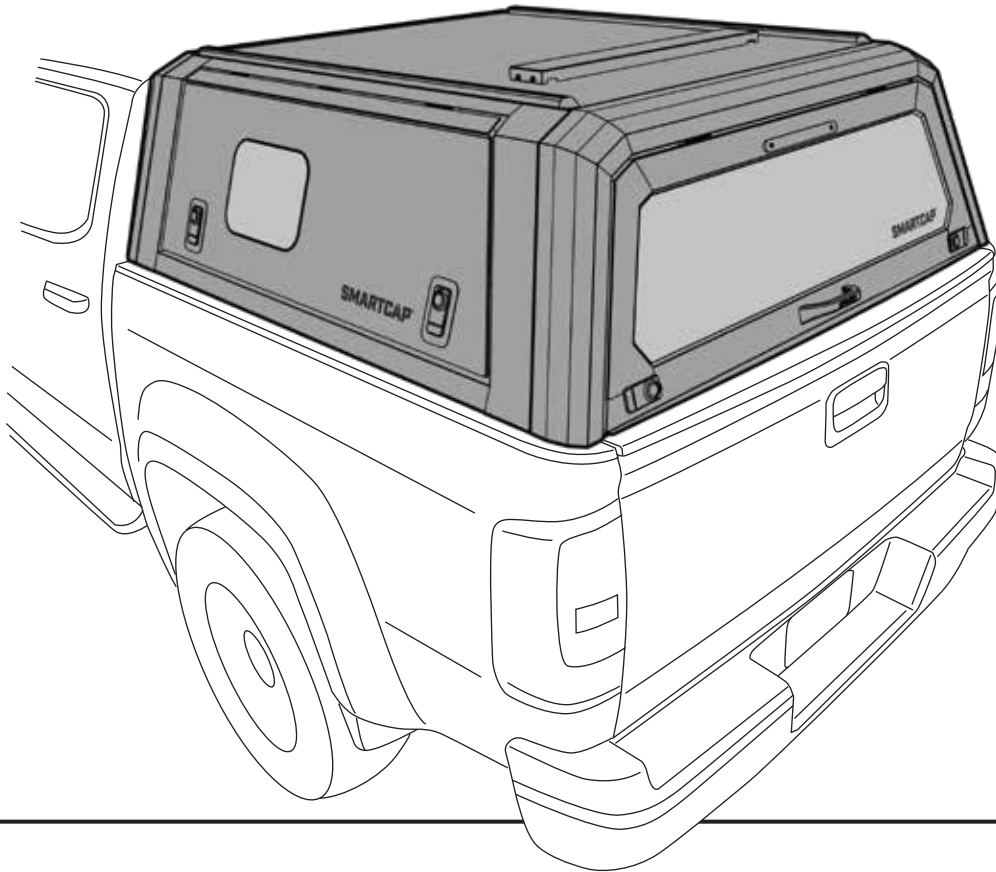

- ▼ **PREPARE A CLEAN WORK AREA.**
- ▼ **WE RECOMMEND A MINIMUM OF 2 PEOPLE FOR ASSEMBLY AND 4 PEOPLE FOR INSTALLATION.**
- ▼ **ENSURE THE REQUIRED TOOLS ARE PRESENT AND ALL HARDWARE CONTENTS ARE ACCOUNTED FOR.**
- ▼ **NEVER USE ACETONE OR THINNERS ON PAINTED PARTS.**
- ▼ **READ THROUGH THE ENTIRE INSTRUCTION GUIDE BEFORE STARTING THIS PROCEDURE AND FOLLOW THE STEPS CAREFULLY TO AVOID ANY DAMAGE TO THE COMPONENTS OR THE VEHICLE.**

**SUPPORT.NA@SMARTCAP.COM - NORTH AMERICA**  
**SUPPORT.SA@SMARTCAP.COM - REST OF WORLD**

**SMARTCAP.COM**



**I-SHEET-NA-TU3**

## TOOLS REQUIRED



### IMPORTANT

- ▼ USE ONLY THE TOOLS RECOMMENDED ABOVE.
- ▼ USE ONLY THE HARDWARE PROVIDED IN THIS KIT.
- ▼ ASSISTANCE WILL BE NEEDED FOR THIS INSTALLATION.  
FOUR PEOPLE ARE RECOMMENDED TO LIFT THE SMARTCAP ONTO THE VEHICLE.
- ▼ AVOID PINCHING OR CRUSHING HANDS AND FINGERS.
- ▼ INSPECT ALL KIT COMPONENTS FOR DAMAGE BEFORE ASSEMBLY.
- ▼ NEVER USE ACETONE OR THINNERS ON PAINTED PARTS.



### IMPORTANT WARRANTY NOTICE

THE 2022+ TOYOTA TUNDRA REQUIRES BED STIFFENERS/J-BRACES TO BE INSTALLED FOR ALL BED RAIL MOUNTED ACCESSORIES. FAILURE TO INSTALL THESE MAY AFFECT THE STRUCTURAL INTEGRITY OF THE TUNDRA'S BED WALLS. THIS NOT ONLY MAY DAMAGE YOUR TRUCK BED, BUT MAY ALSO LEAD TO SMARTCAP REAR FLANGE WELDING FAILURES AND OTHER CRITICAL DAMAGE. PLEASE NOTE, DAMAGE TO YOUR SMARTCAP THAT IS DIRECTLY ATTRIBUTABLE TO NOT HAVING BED STIFFENERS/J-BRACES INSTALLED WILL NOT BE COVERED UNDER THE SMARTCAP 3-YEAR WARRANTY. SMARTCAP DOES NOT OFFER BED STIFFENERS, BUT AN INTERNET SEARCH WILL SHOW MULTIPLE AVAILABLE OPTIONS.

#### BED STIFFENER BRACKETS (NOT INCLUDED WITH PURCHASE)

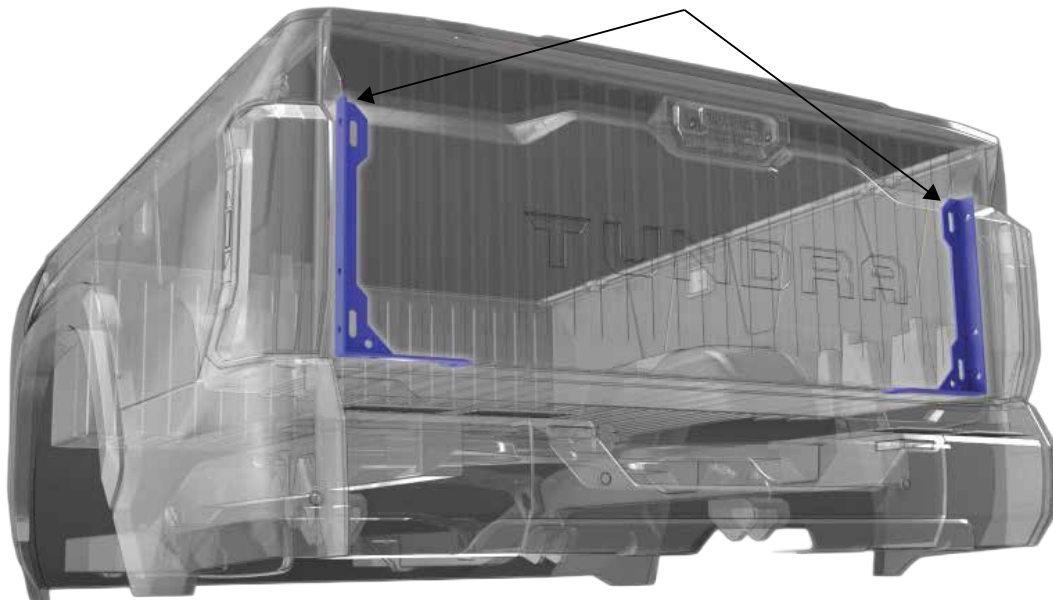

# COMPONENTS & ASSEMBLY HARDWARE

## COMPONENTS

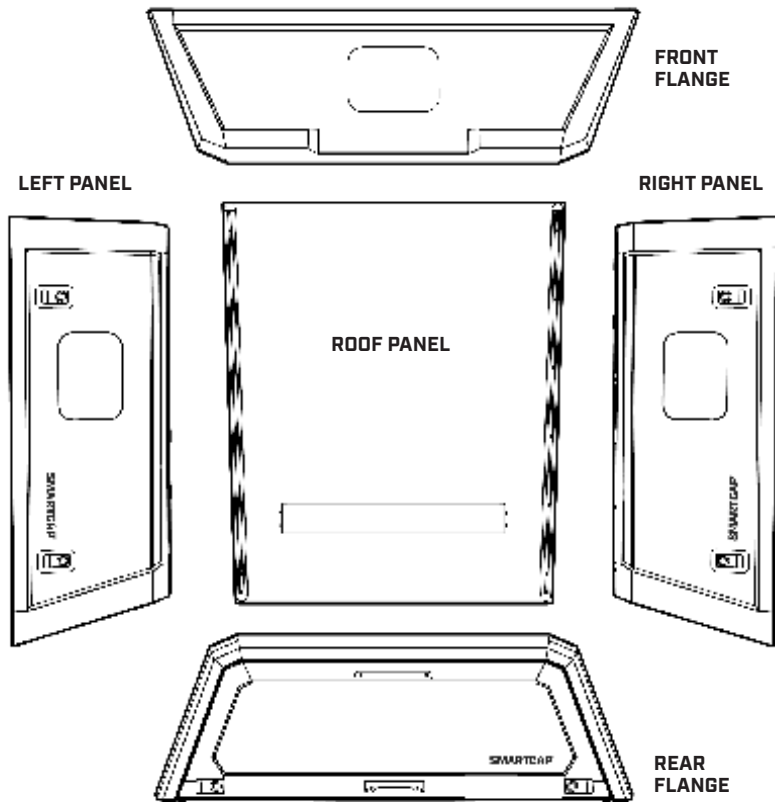

## FITMENT KIT

M6 BOLT



FASTENER  
BLOCK CLAMP

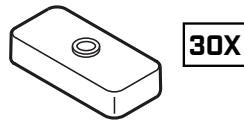

M6 LOCK  
WASHER



FASTENER  
BLOCK

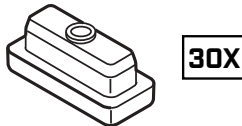

D - RUBBER



SPARE PARTS

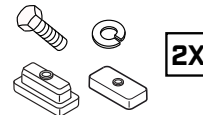

## PRE-FASTENED TO ROOF PANEL

M6 FENDER  
WASHER



12X SHORT BED  
14X STANDARD BED

M6 LOCK  
NUT



12X SHORT BED  
14X STANDARD BED

# STEP 1



## IMPORTANT

- ▼ BE SURE TO REMOVE ALL FIVE PANELS FROM THEIR PACKAGING AND INSPECT THE PAINTED SURFACES PRIOR TO ASSEMBLY, AS SMARTCAP WILL NOT ACCEPT WARRANTY CLAIMS AFTER ASSEMBLY IS COMPLETED. IF MANUFACTURING IMPERFECTIONS OR SHIPPING DAMAGES ARE FOUND, DO NOT CONTINUE WITH THE ASSEMBLY PROCESS AND CONTACT [SUPPORT.NA@SMARTCAP.COM](mailto:SUPPORT.NA@SMARTCAP.COM).

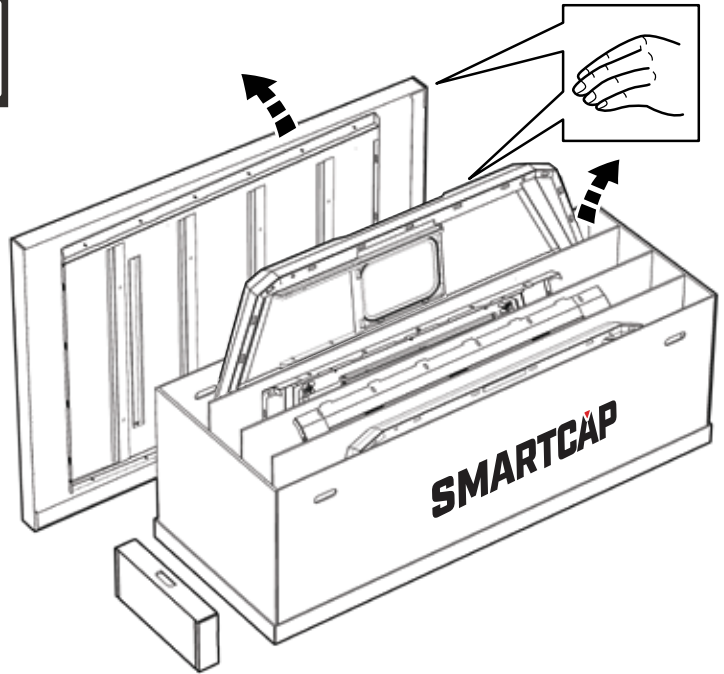

# STEP 2

PLACE THE ROOF PANEL WHERE YOU PLAN TO ASSEMBLE THE CAP. REMOVE THE LID FROM THE PACKAGING AND PLACE IT NEXT TO THE ROOF PANEL.

LOGO SIDE UP

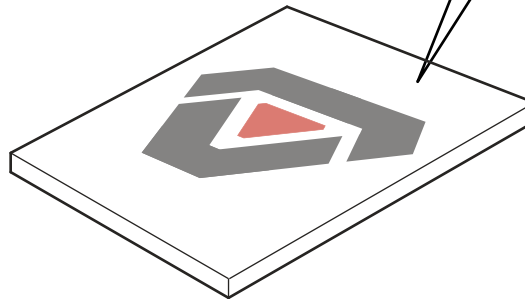

USE LID AS WORK SURFACE

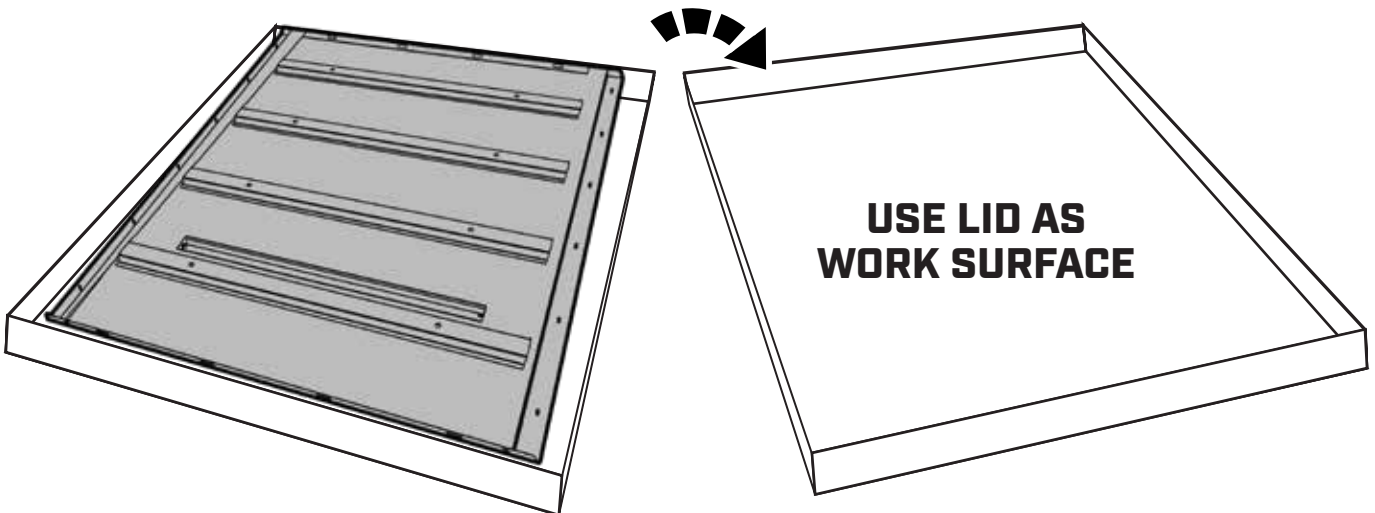

# STEP 3

USE A 10MM COMBINATION WRENCH TO REMOVE ALL HARDWARE FROM THE ROOF PANEL AND SAVE FOR REUSE.



**AIR VENT INDICATES REAR**

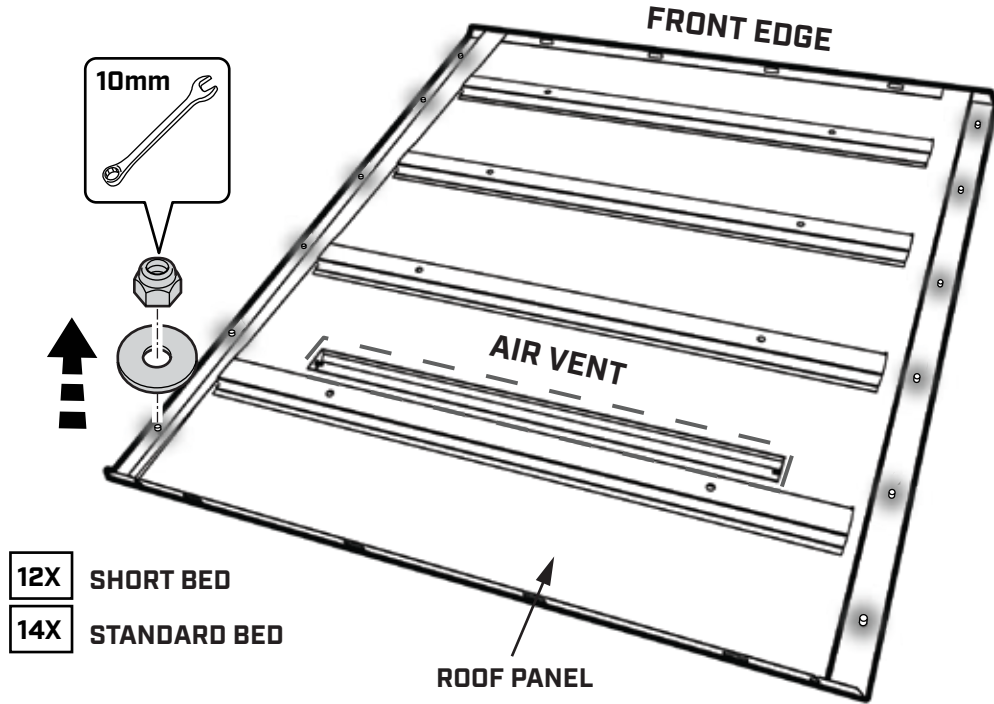

# STEP 4

LOCATE THE RIGHT PANEL IN THE SMARTCAP PACKAGE AND BRING IT TO YOUR WORK AREA.

2 PERSON JOB



**SLANTED EDGE INDICATES REAR**

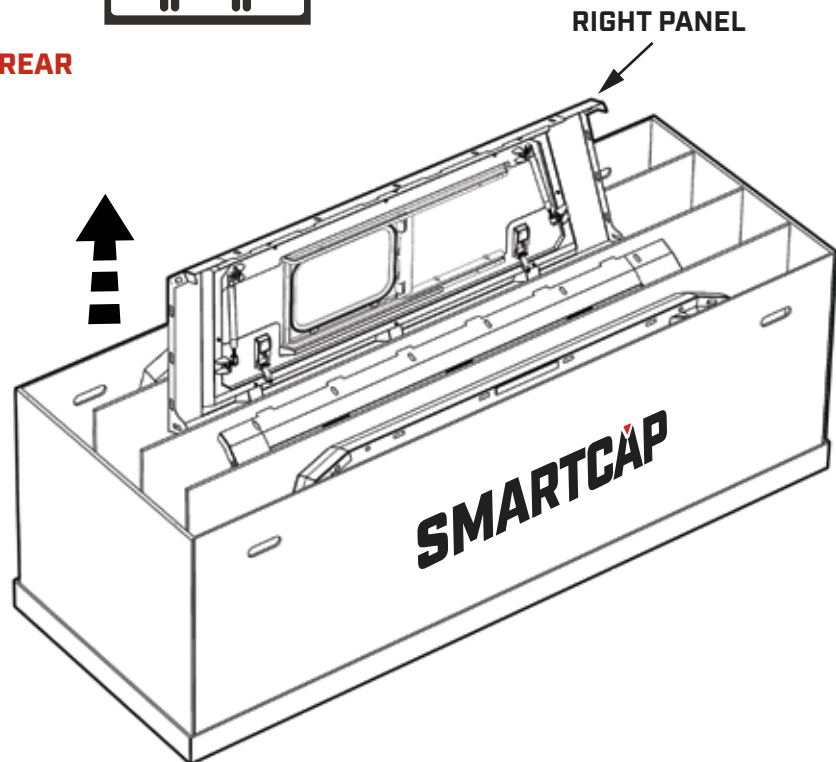

# STEP 5

INSERT PANEL TABS INTO NARROW SLOTS JUST ABOVE FOAM PADDING ON ROOF PANEL.

TAP FIRMLY WITH PALM OF HAND UNTIL THERE IS A 2-3MM GAP.

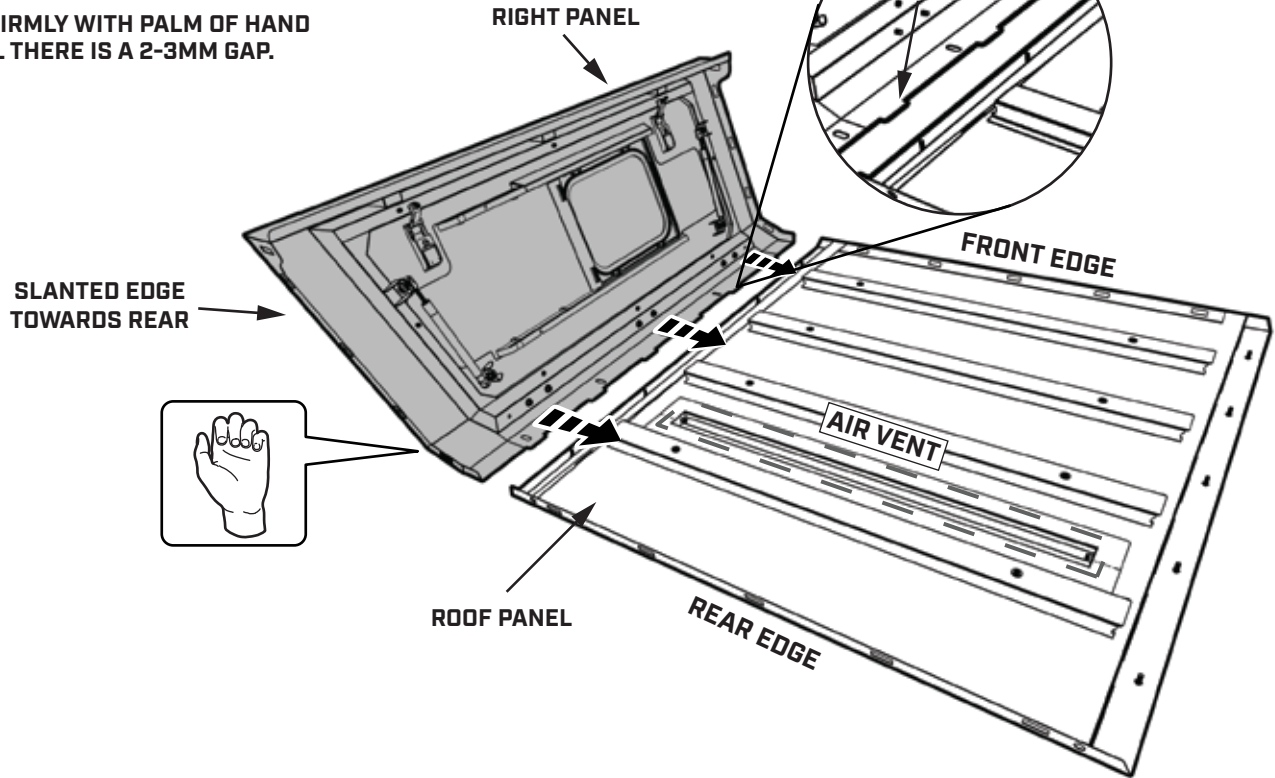

# STEP 6

HAND TIGHTEN M6 LOCK NUT WITH M6 FENDER WASHER TO ALL BOLTS.

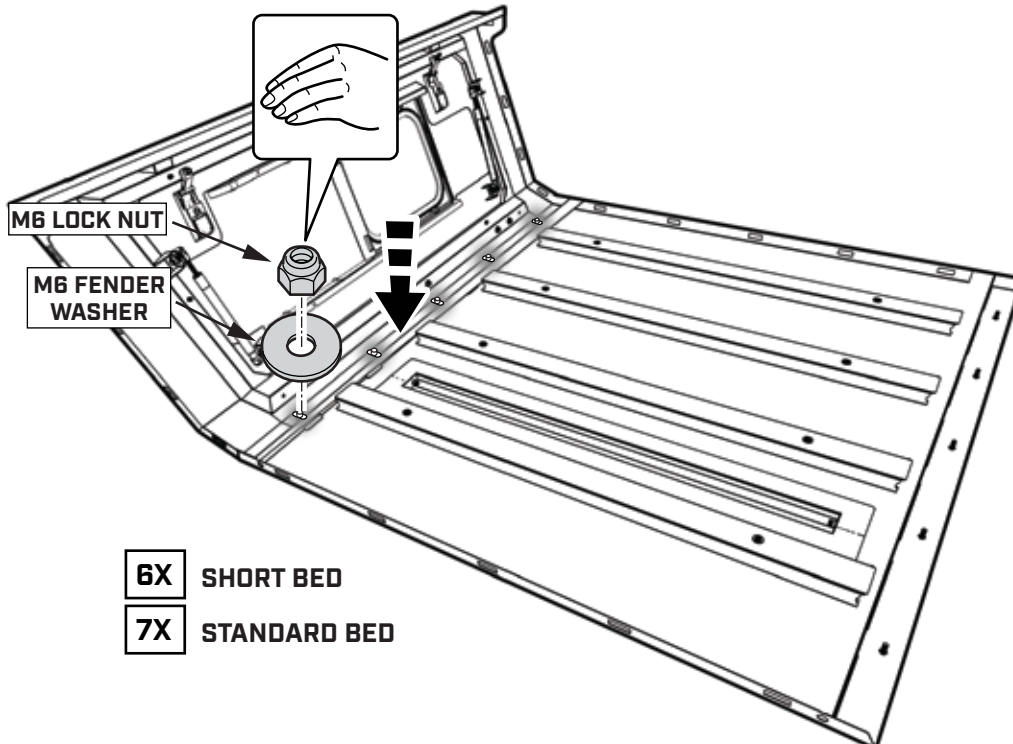
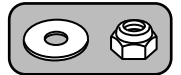

- 6X SHORT BED
- 7X STANDARD BED

# STEP 7

LOCATE THE LEFT PANEL IN THE SMARTCAP PACKAGE AND BRING IT TO YOUR WORK AREA.



**SLANTED EDGE INDICATES REAR**

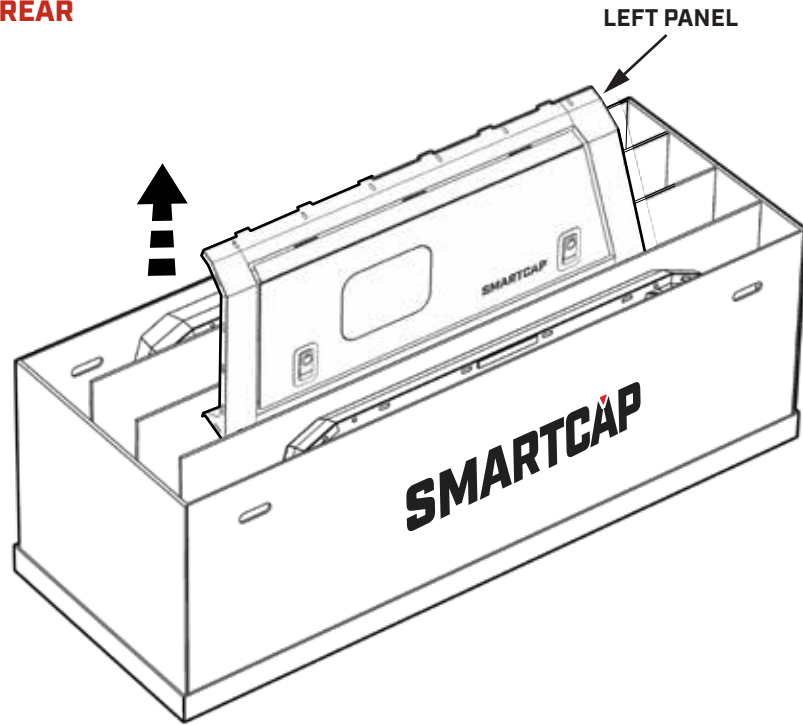

# STEP 8

INSERT PANEL TABS INTO NARROW SLOTS JUST ABOVE FOAM PADDING ON ROOF PANEL.



TAP FIRMLY WITH PALM OF HAND UNTIL THERE IS A 2-3MM GAP.

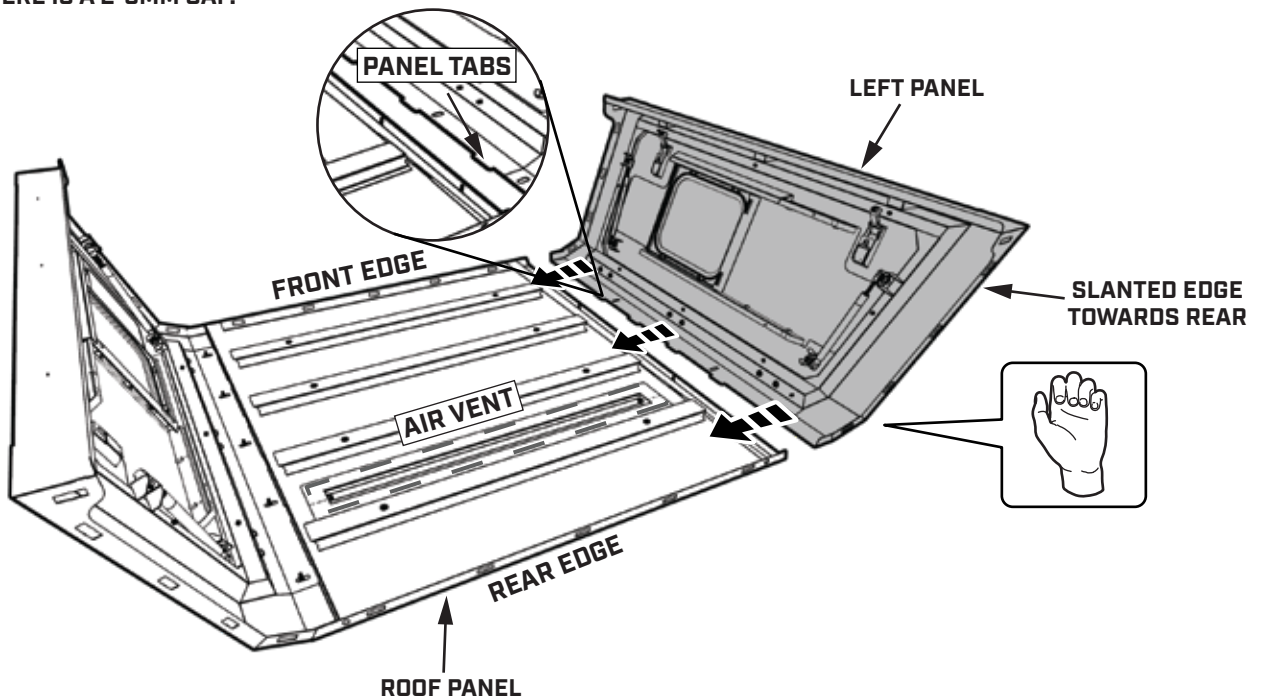

# STEP 9

HAND TIGHTEN M6 LOCK NUT WITH M6 FENDER WASHER TO ALL BOLTS.

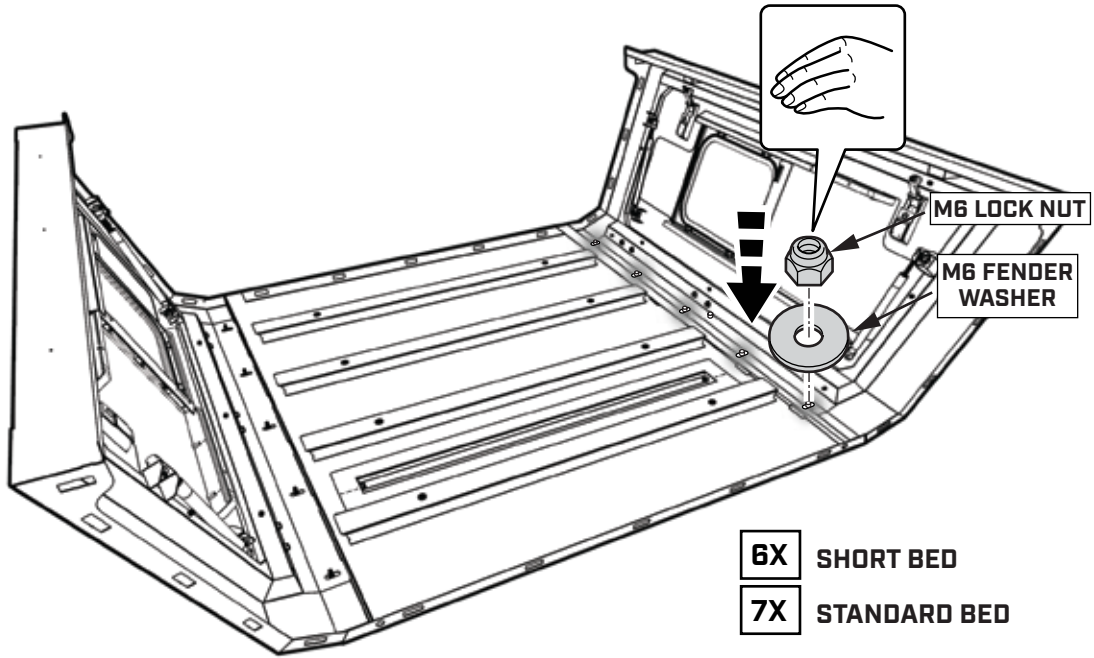
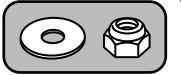

# STEP 10

PUSH THE SMARTCAP TO EXPOSE A FEW INCHES OF STYROFOAM UNDERNEATH THE ROOF PANEL TO PROVIDE SUPPORT FOR THE FRONT FLANGE.

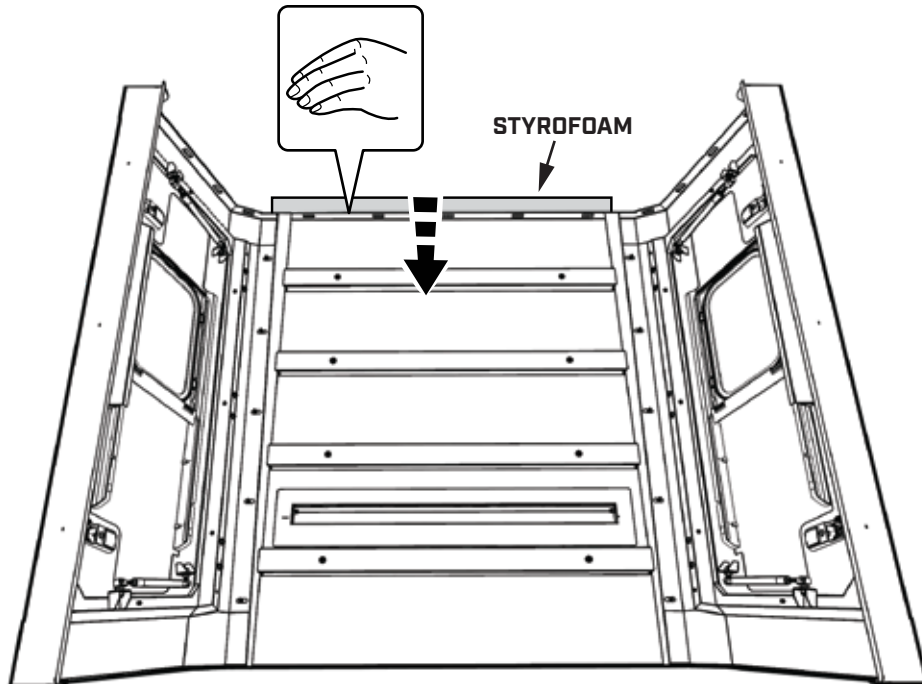

# STEP 11

RETRIEVE THE NECESSARY HARDWARE FROM THE FITMENT KIT.

LOCATE THE FRONT FLANGE IN THE SMARTCAP PACKAGE AND BRING IT TO YOUR WORK AREA.

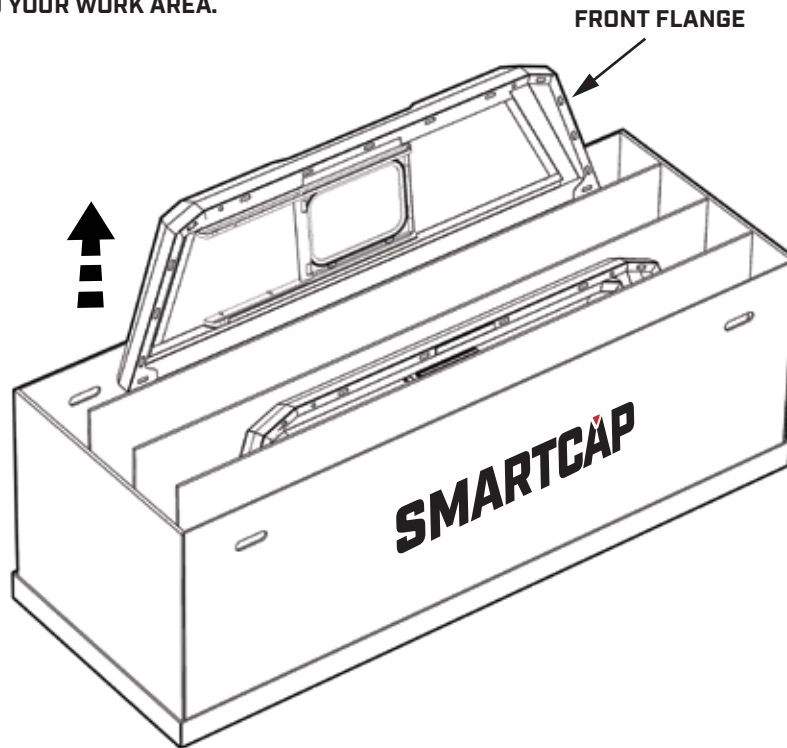
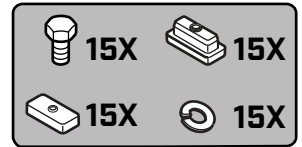

# STEP 12

PLACE FRONT FLANGE AS SHOWN BELOW.

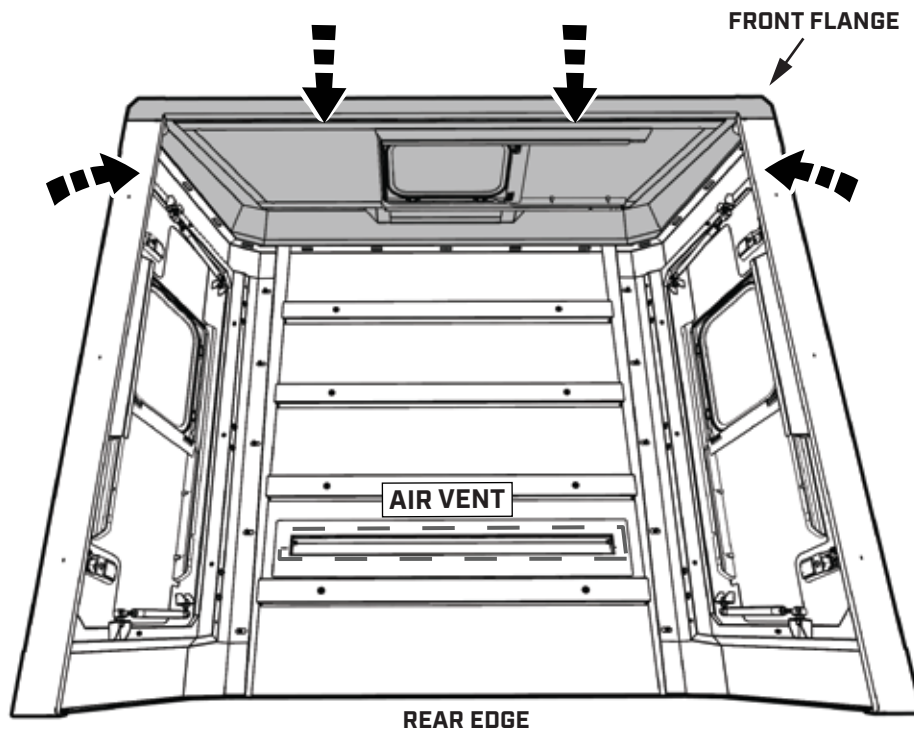

# STEP 13

INSTALL HARDWARE ALONG FRONT FLANGE WITH M6 BOLT ON INSIDE.

START WITH ASSEMBLING FASTENER BLOCKS 1-5.

ADJUST LEFT AND RIGHT PANELS TO ALIGN FASTENER BLOCKS 6-15 FOR ASSEMBLY.

HAND TIGHTEN IN THE SEQUENCE SHOWN.

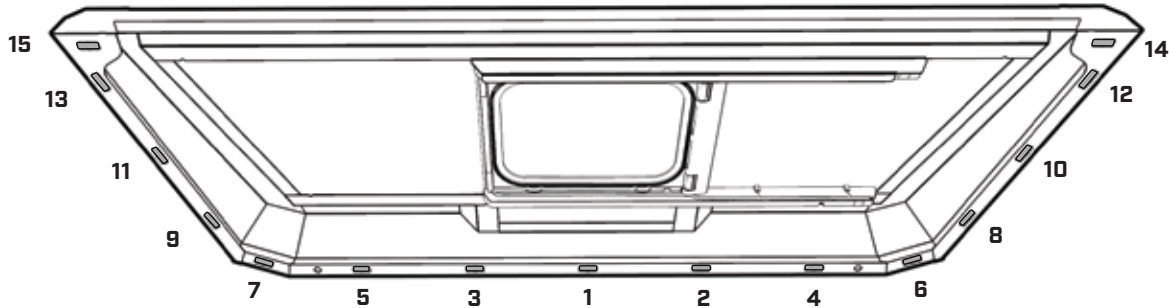
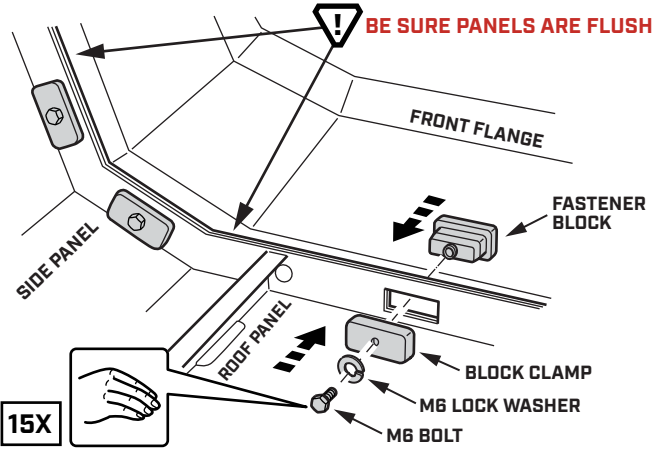

# STEP 14

PUSH THE SMARTCAP TO EXPOSE A FEW INCHES OF STYROFOAM UNDERNEATH THE ROOF PANEL TO PROVIDE SUPPORT FOR THE REAR FLANGE.

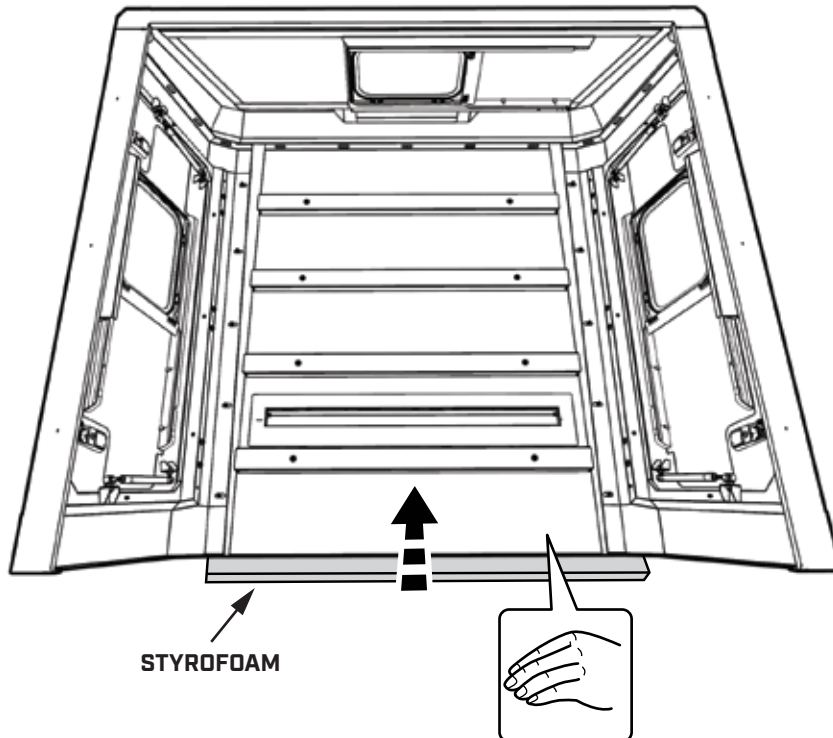

# STEP 15

RETRIEVE THE NECESSARY HARDWARE FROM THE FITMENT KIT.

LOCATE THE REAR FLANGE IN THE SMARTCAP PACKAGE AND BRING IT TO YOUR WORK AREA.

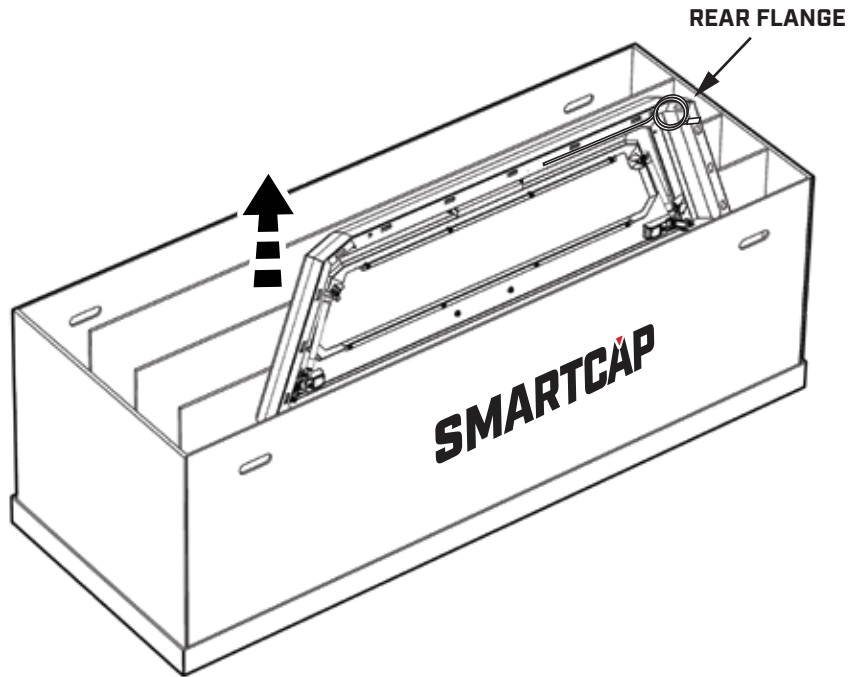
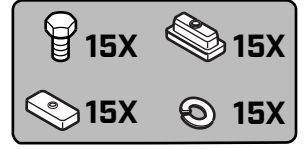

# STEP 16

PLACE REAR FLANGE AS SHOWN BELOW.

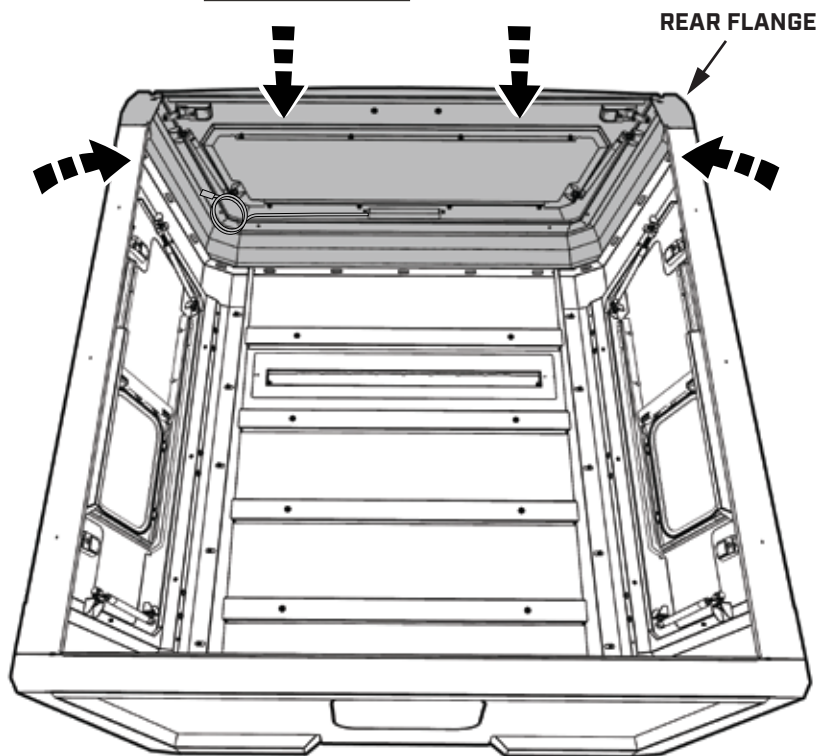

# STEP 17

INSTALL HARDWARE ALONG REAR FLANGE WITH BOLT ON INSIDE.

START WITH ASSEMBLING FASTENER BLOCKS 1-5.

ADJUST LEFT AND RIGHT PANELS TO ALIGN FASTENER BLOCKS 6-15 FOR ASSEMBLY.

HAND TIGHTEN IN THE SEQUENCE SHOWN.

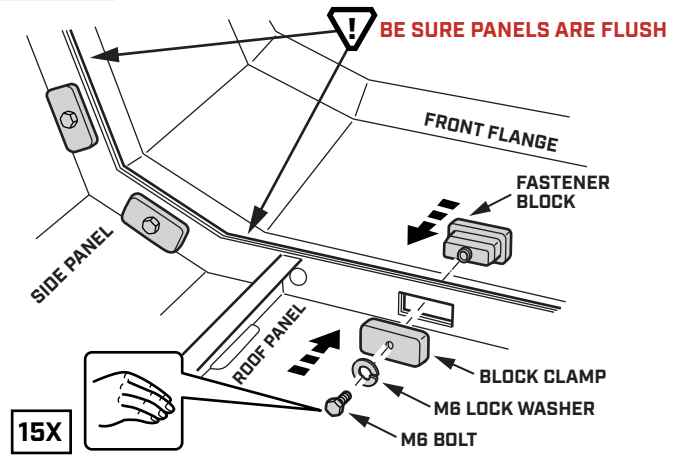

# STEP 18

TIGHTEN ALL HARDWARE WITH TORQUE WRENCH AND 10MM SOCKET TO 3.7 FT. LBS. [5 NEWTON METERS]



[3.7 ft. lbs]/[5 Nm]

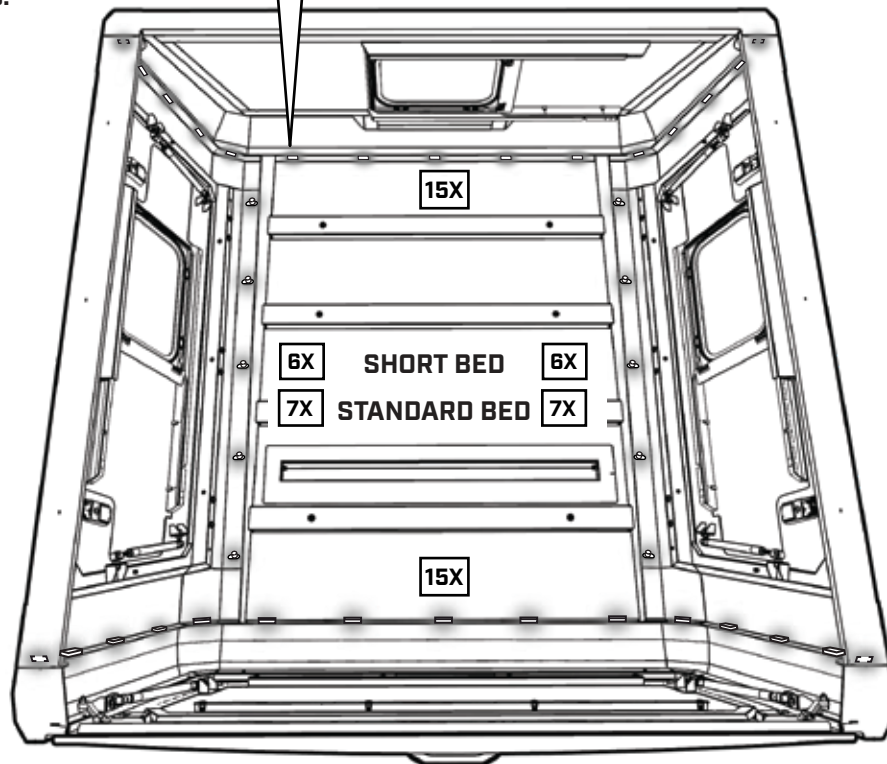

# STEP 19

ENSURE THE ENTIRE BOTTOM EDGE OF THE SMARTCAP IS CLEAN.

LOCATE BOTH RETENTION TABS ON THE REAR FLANGE AND BEND EACH TO A 45-DEGREE ANGLE FOR D-RUBBER FITMENT.



**LOCATE RETENTION TABS**

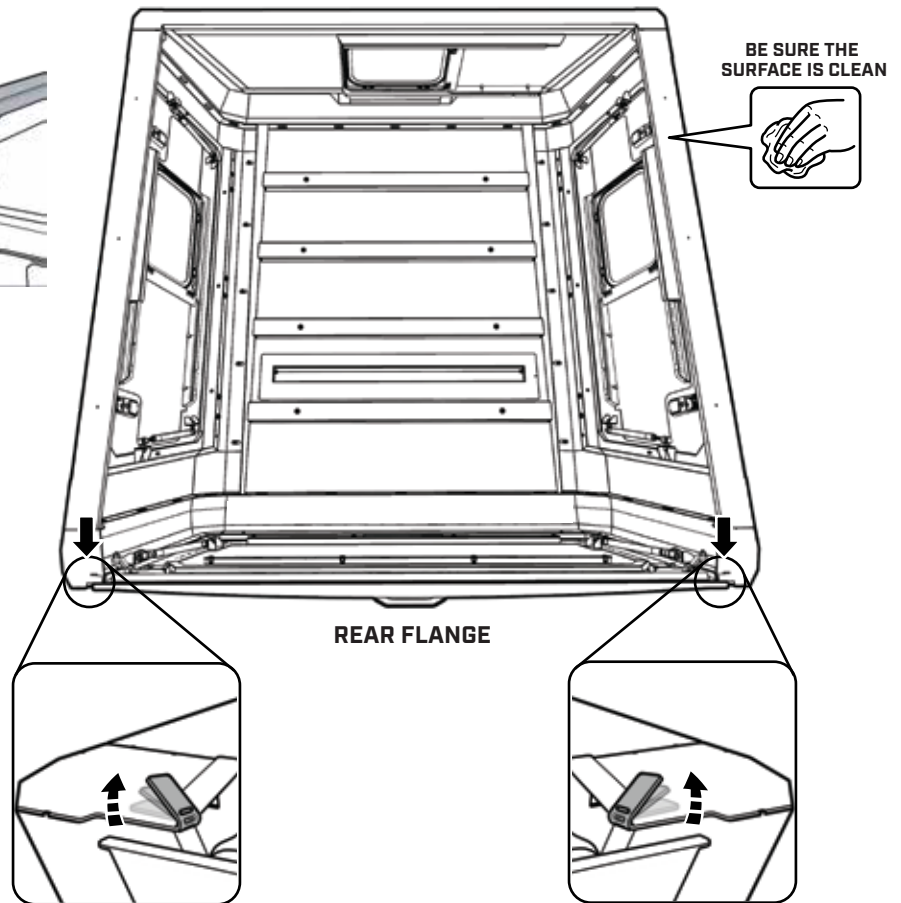

# STEP 20

TRIM THE D-RUBBER WITH A CLEAN, STRAIGHT CUT.

APPLY 2-3 INCHES OF GEL SUPER GLUE NEAR THE RETENTION TABS, ALONG THE BOTTOM EDGE OF THE REAR FLANGE

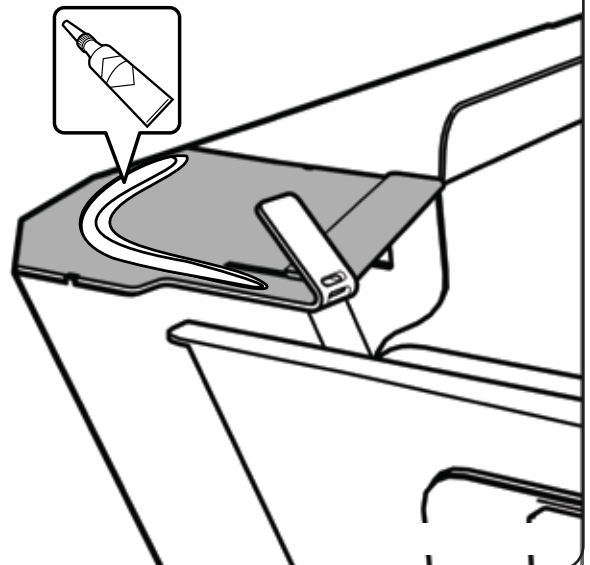
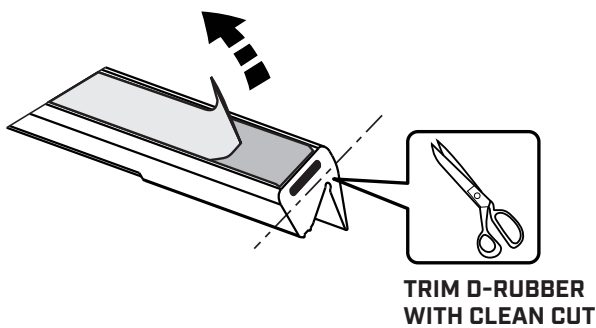

## STEP 21

FULLY INSERT THE RETENTION TAB INTO THE SLOT ON THE D-RUBBER. ENSURE THE D-RUBBER IS ORIENTED CORRECTLY WITH ITS PROFILE MATCHING THE CONTOUR OF THE REAR FLANGE.

PRESS DOWN FIRMLY ON THE TAB AND THE D-RUBBER TO BOND IT TO THE REAR FLANGE, CREATING A TIGHT SEAL.

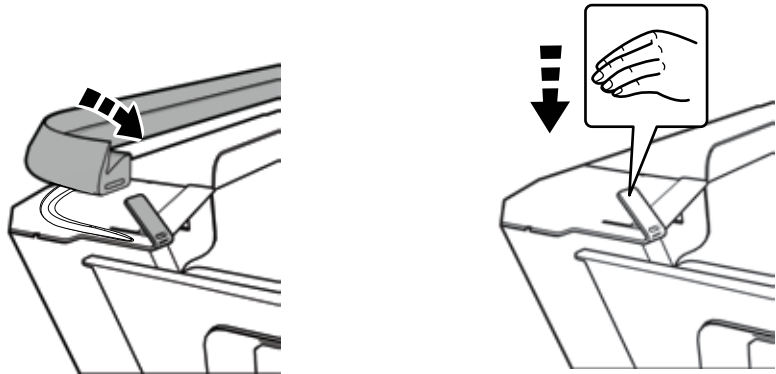

**CORRECT D-RUBBER ORIENTATION**

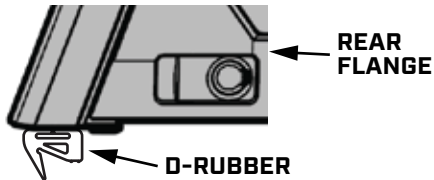

**INCORRECT D-RUBBER ORIENTATION**

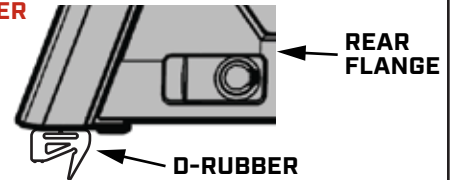

## STEP 22

ALIGN THE D-RUBBER ALONG THE SMARTCAP'S EDGE, MAINTAINING A CONSISTENT 1/8 INCH GAP FROM THE EDGE.

START FROM ONE CORNER AND WORK YOUR WAY AROUND THE CAP TO ENSURE PROPER PLACEMENT AND ALIGNMENT.

APPLY 2-3 INCHES OF GEL SUPER GLUE AT THE FRONT CORNERS OF THE SMARTCAP, ALONG THE BOTTOM EDGE OF THE FRONT FLANGE.

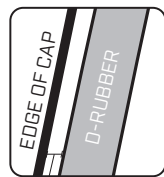

1/8 INCH FROM EDGE

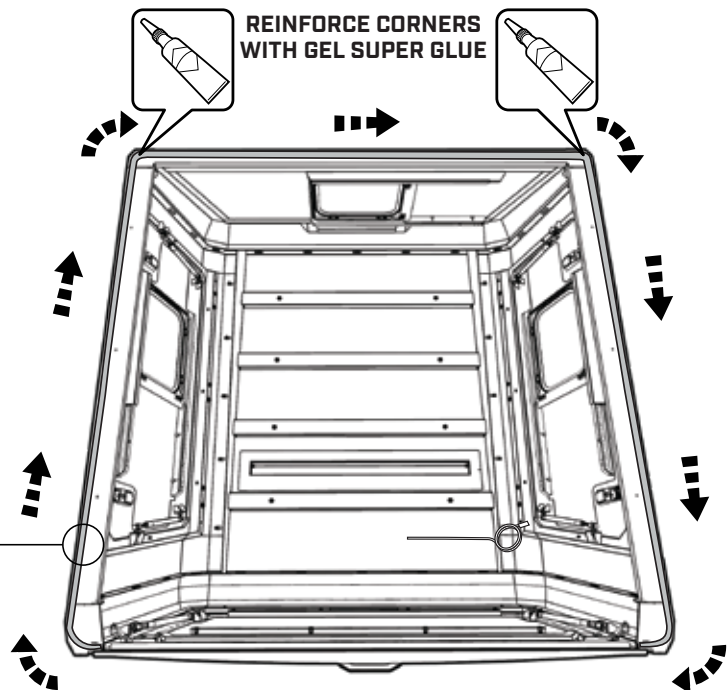

## STEP 23

TRIM ANY EXCESS D-RUBBER BEYOND THE EDGE FOR A NEAT FINISH.

APPLY 2-3 INCHES OF GEL SUPER GLUE NEAR THE RETENTION TAB, ALONG THE BOTTOM EDGE OF THE REAR FLANGE. FULLY INSERT THE RETENTION TAB INTO THE SLOT ON THE D-RUBBER.

PRESS DOWN FIRMLY ON THE TAB AND THE D-RUBBER TO BOND IT TO THE REAR FLANGE, CREATING A TIGHT SEAL.

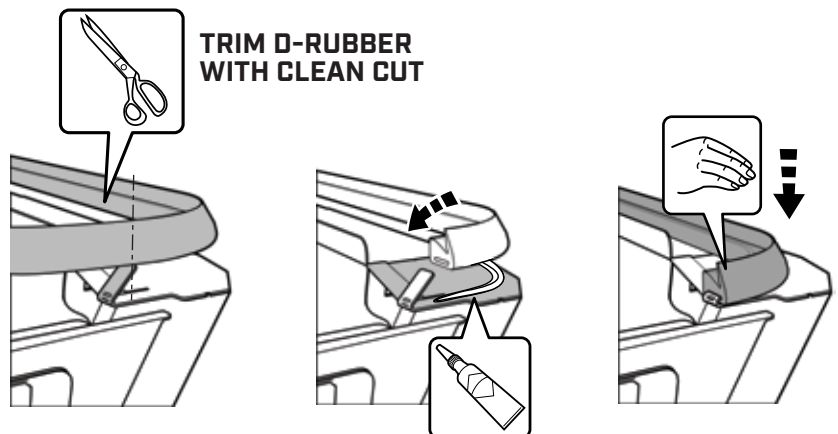

## INSTALLATION HARDWARE

### THIN RUBBER PAD

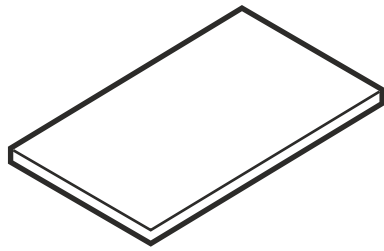

6X

### MOUNTING CLAMP

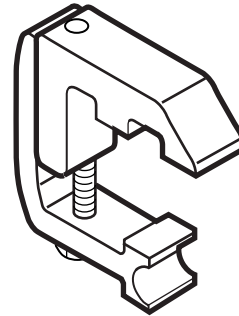

6X

### THICK RUBBER PAD

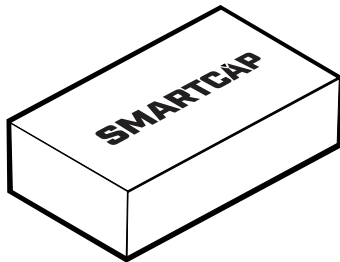

8X

### FOAM SEAL TAPE

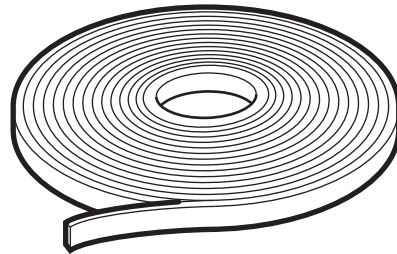

1X

## VEHICLE INSTALLATION



### IMPORTANT

- ▼ ASSISTANCE WILL BE NEEDED FOR THIS INSTALLATION. FOUR PEOPLE ARE RECOMMENDED TO LIFT THE SMARTCAP ONTO THE VEHICLE.
- ▼ AVOID PINCHING OR CRUSHING HANDS AND FINGERS.
- ▼ READ THROUGH THE ENTIRE PROCEDURE BEFORE STARTING.

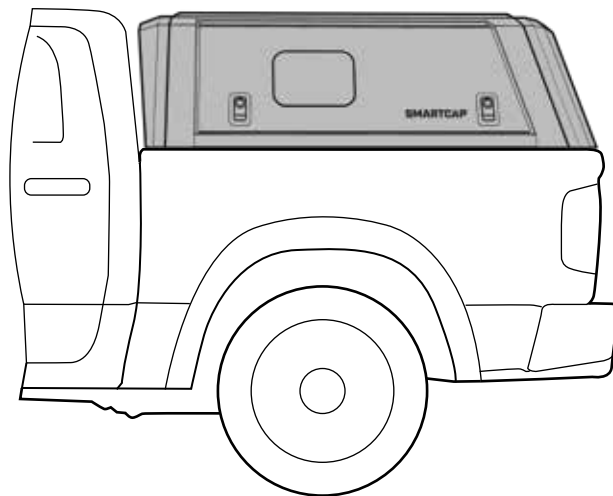

# STEP 24

REMOVE THE ADHESIVE BACKING FROM THE THICK RUBBER PAD.

PLACE THE PADS ALONG THE INSIDE OF THE D-RUBBER AT THE INDICATED LOCATIONS.

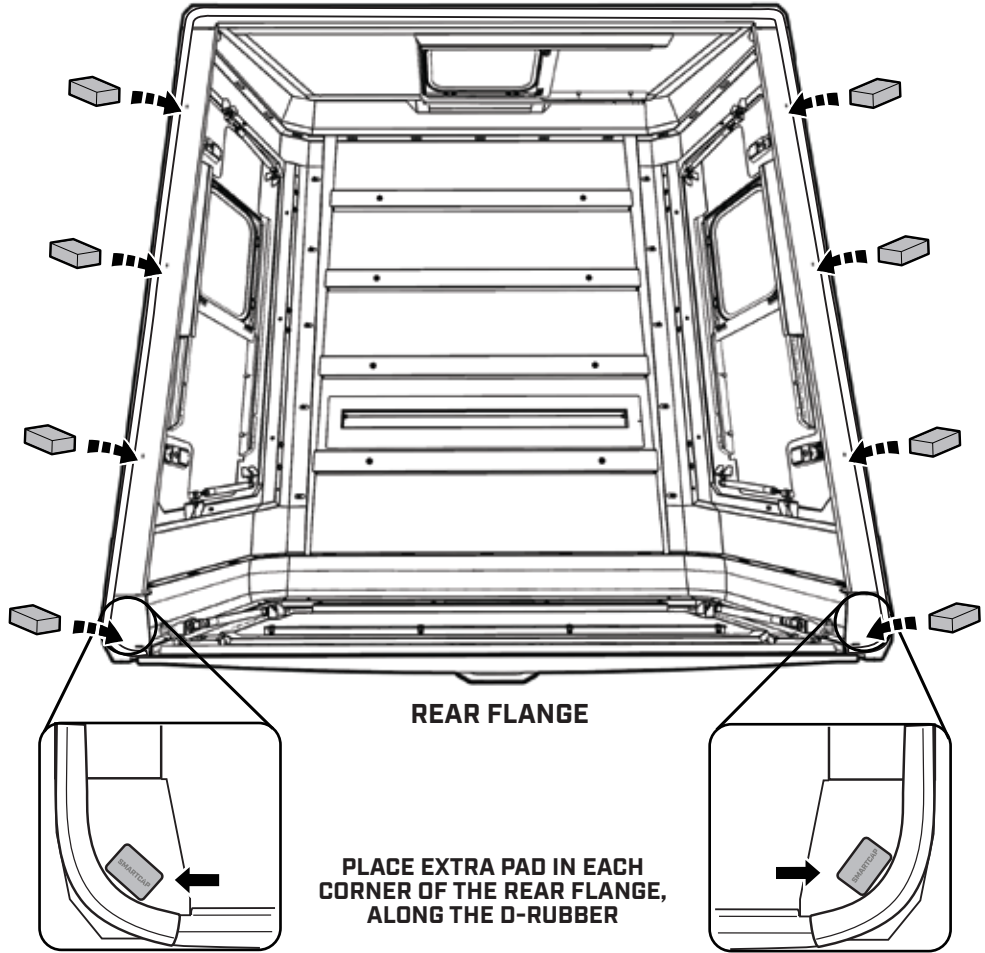
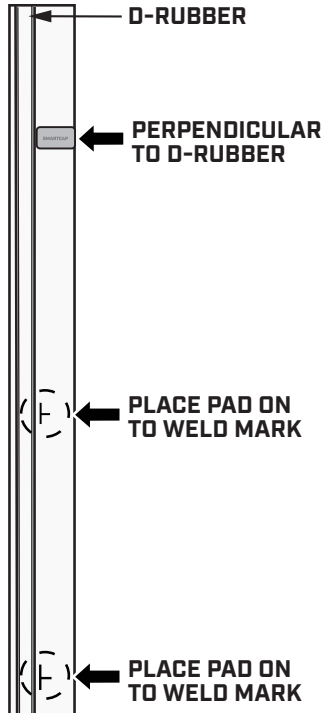

# STEP 25

INSPECT THE TRUCK BED. IF FRONT EDGE IS LOWER THAN THE SIDES, ADD FOAM SEAL TAPE TO THE FRONT EDGE OF THE BED.

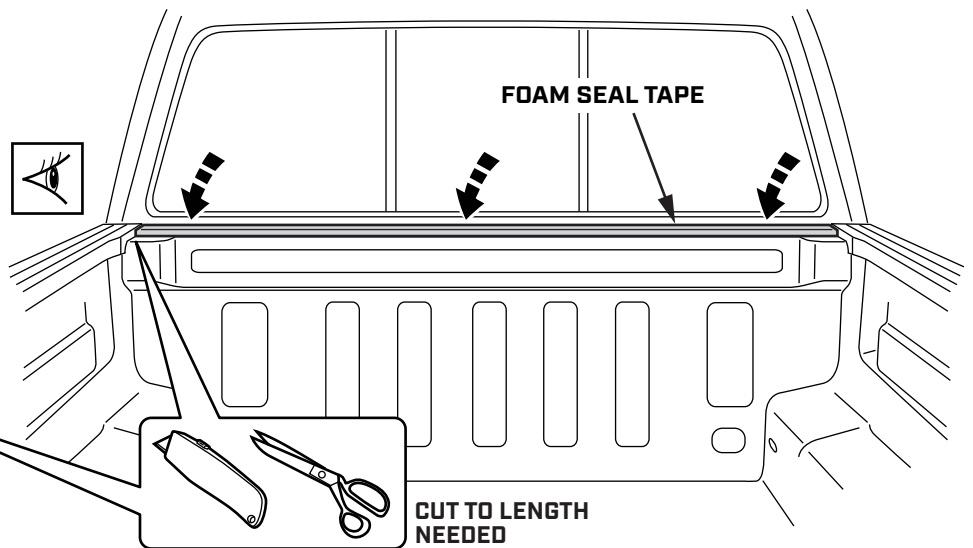
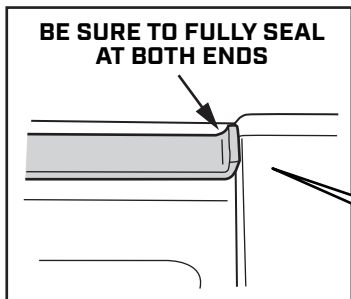
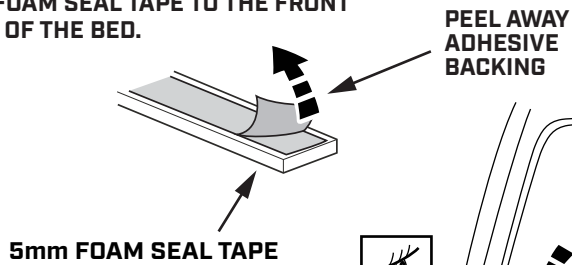
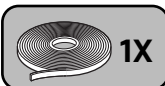

## STEP 26

CAREFULLY PULL UP ON THE PLASTIC PANEL OF THE TRUCK BED RAILING, EXPOSING THE SHEET METAL.

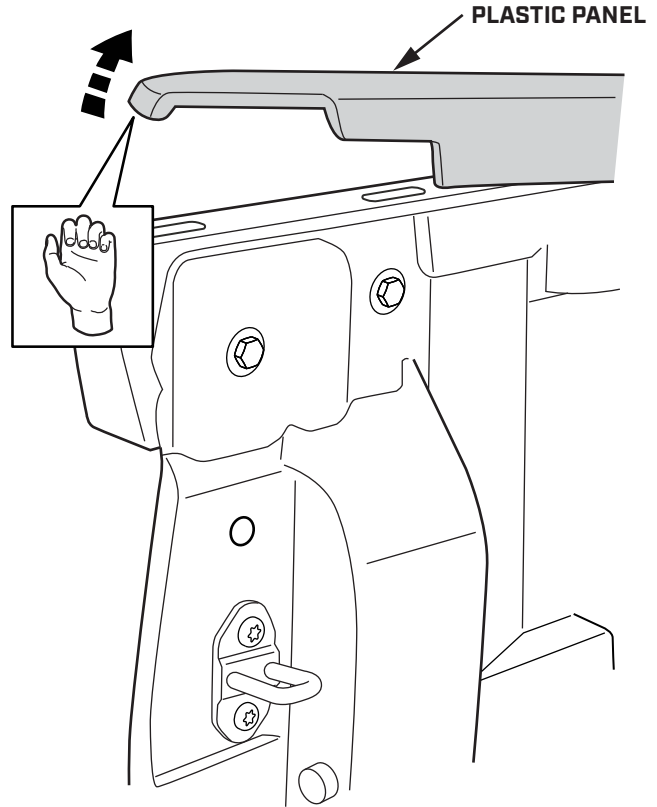

## STEP 27

RETRIEVE THE THIN RUBBER PADS FROM THE FITMENT KIT.

USING A PAIR OF SCISSORS, TRIM A 1/2" STRIP FROM EACH OF THE 6 THIN RUBBER PADS.

PLACE THE PADS ON THE SHEET METAL OF THE TRUCK BED RAILING AS SHOWN.

**REPEAT ON OPPOSITE SIDE**

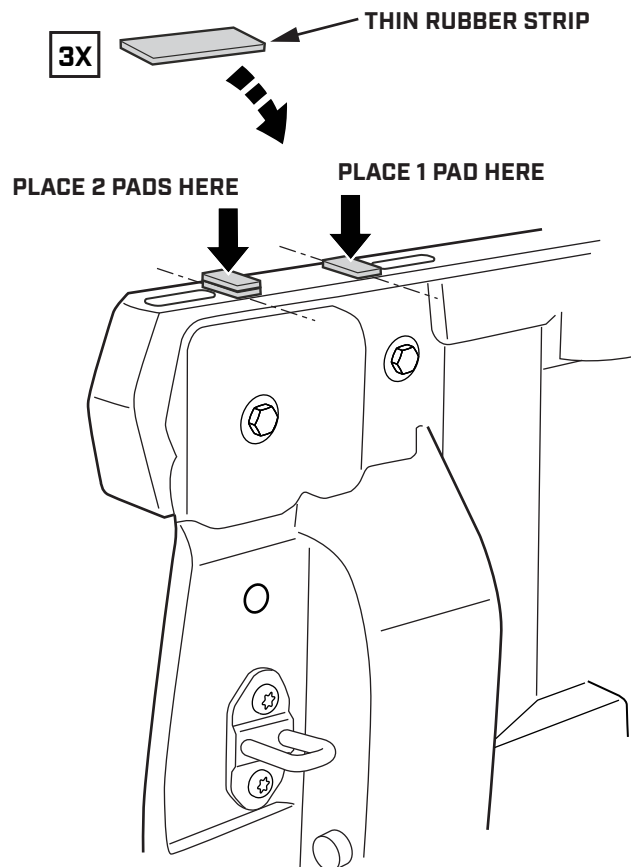
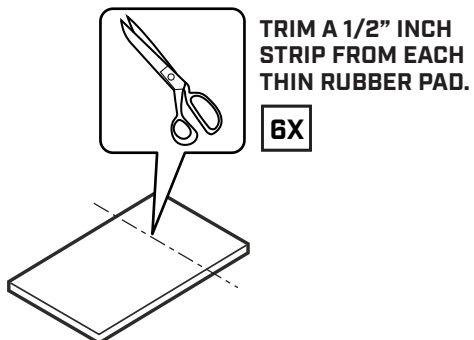

## STEP 28

FIRMLY SECURE THE PLASTIC PANELS OF THE TRUCK BED RAILING BACK IN PLACE.

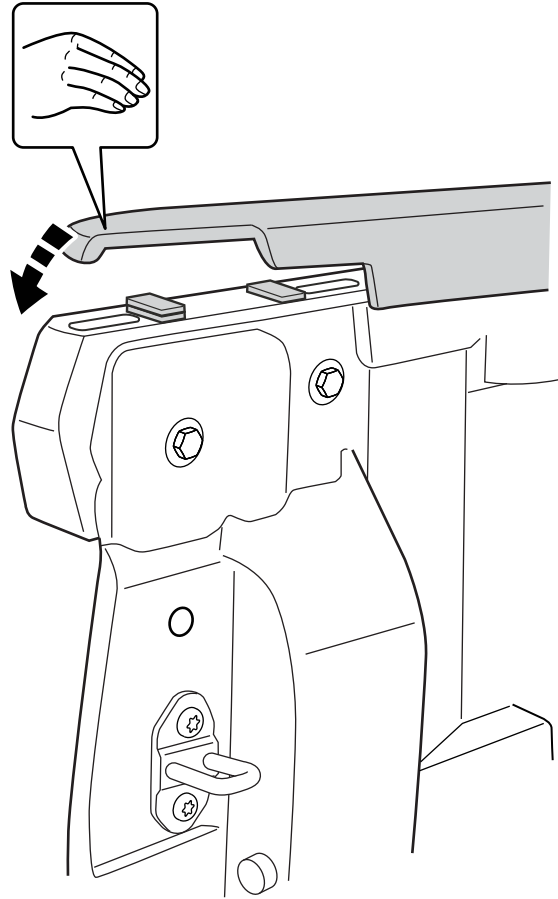

## STEP 29

USE 4 PEOPLE TO LIFT THE ASSEMBLED SMARTCAP ONTO THE TRUCK BED.

TO AVOID DAMAGE TO THE D-RUBBER, DO NOT SLIDE THE SMARTCAP INTO PLACE.

**4 PERSON JOB**

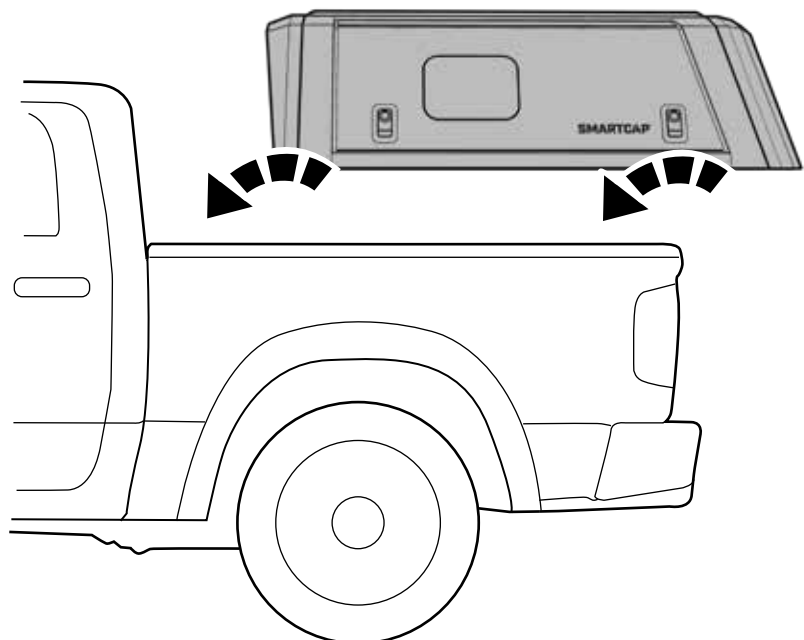

## STEP 30

CHECK THAT THE SMARTCAP IS PROPERLY POSITIONED AND CENTERED ON THE TRUCK BED.

IT'S IMPORTANT THAT THE SMARTCAP IS NOT PUSHED TOO FAR FORWARD, LEAVING A GAP BETWEEN THE SMARTCAP AND THE CAB.

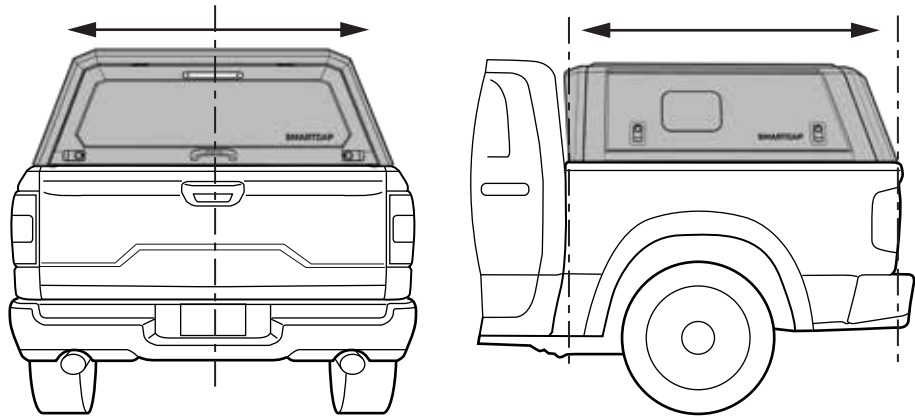

## STEP 31

WALK AROUND THE TRUCK BED TO MAKE SURE THE D-RUBBER FITMENT IS CORRECT AND THAT THE RUBBER LIP IS PROPERLY TUCKED UNDERNEATH THE CAP.



**USING A SHARP KNIFE, CUT AWAY THE BOTTOM SECTION OF THE D-RUBBER TO PROVIDE CLEARANCE FOR THE TAILGATE. MEASURE WHERE THE CAP OVERLAPS THE TAILGATE TO DETERMINE HOW FAR THE D-RUBBER BOTTOM SHOULD BE TRIMMED.**

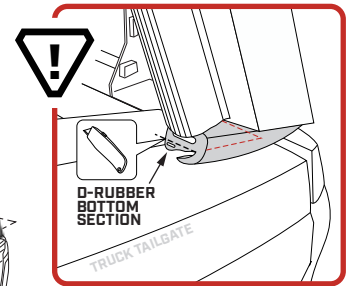
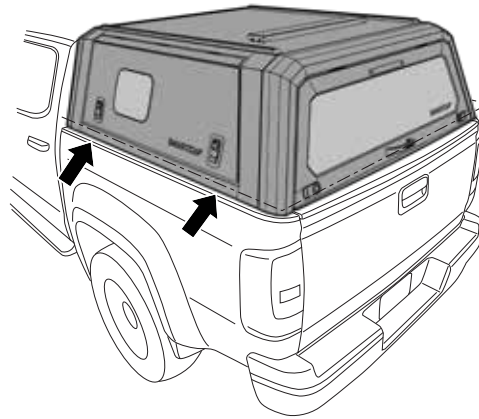

**\*DO NOT TRIM THE LIP**

*\*YOU MAY NOTICE THAT THE SEAL ON THE SLIDING PORTAL WINDOW MIGHT APPEAR WRINKLED. THIS IS DUE TO THE ANTI-SLIP COATING AND IS NOT A CAUSE FOR CONCERN.*

## STEP 32

WITH THE EXCEPTION OF THE REAR CORNERS, PLACE THE THIN RUBBER PADS NEXT TO THE GUSSETS ON BOTH SIDES OF THE CAP.

MAKE SURE THE THIN RUBBER PADS ARE PLACED DIRECTLY ABOVE WHERE THE THICK RUBBER PADS ARE LOCATED ALONG THE BOTTOM OF THE CAP.

**3 PADS PER SIDE**

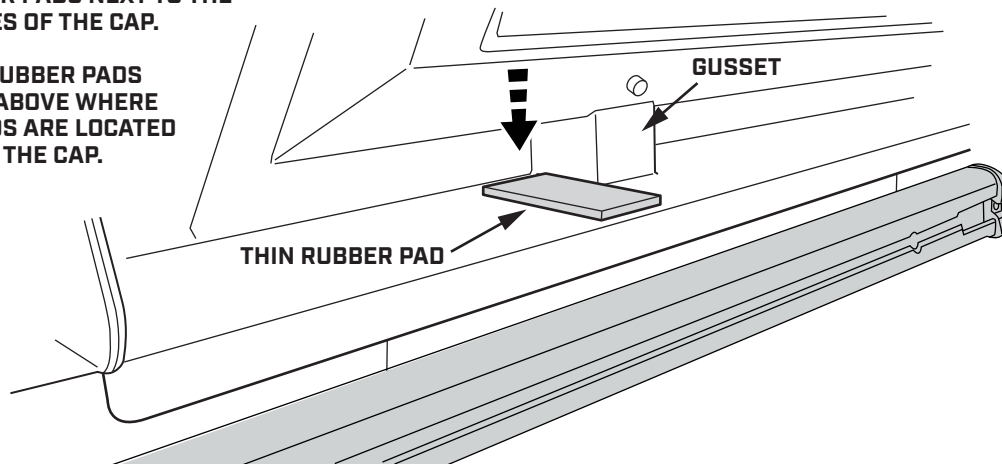

# STEP 33

DISASSEMBLE MOUNTING CLAMPS.

INSTALL LOWER CLAMP ARMS INTO RAIL  
INSIDE THE TRUCK BED AND SET THEM IN  
FRONT OF EVERY THIN RUBBER PAD.

**3 CLAMPS PER SIDE**



LOWER CLAMP ARM

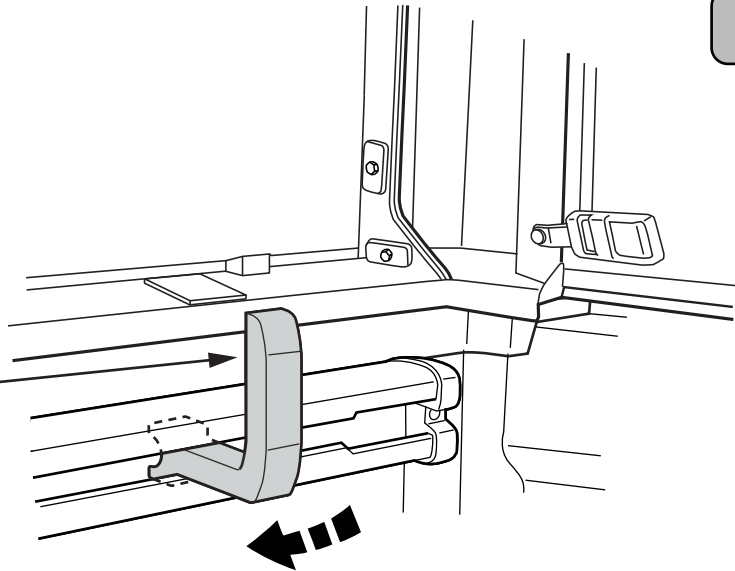

# STEP 34

REASSEMBLE UPPER AND LOWER  
CLAMP ARMS.

HAND TIGHTEN ALL MOUNTING CLAMPS  
ON TOP OF THIN RUBBER PADS.

UPPER CLAMP ARM

LOWER CLAMP ARM

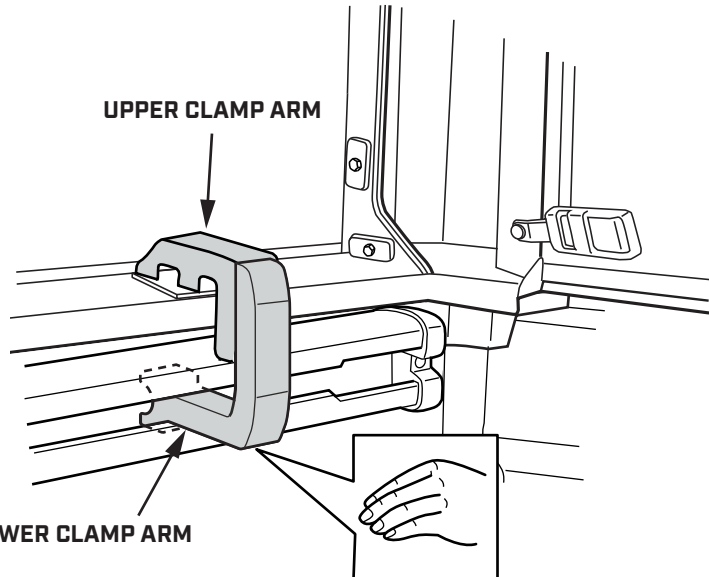

# STEP 35

TIGHTEN MOUNTING CLAMPS  
USING TORQUE WRENCH AND  
13MM SOCKET TO 4.4 FT. LBS.  
[6 NEWTON METERS]

GAP REQUIRED =  
13mm [1/2 INCH]

SMARTCAP

TRUCK BED

13mm

[4.4 ft. lbs.]  
[6 Nm]

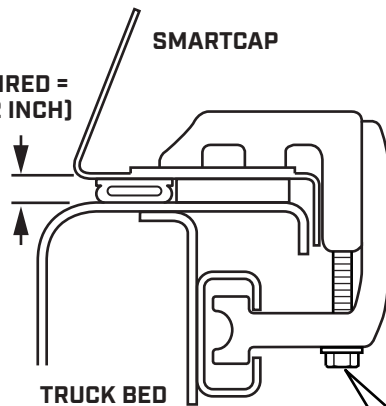

## THIRD BRAKE LIGHT HARDWARE

### T-HARNESS

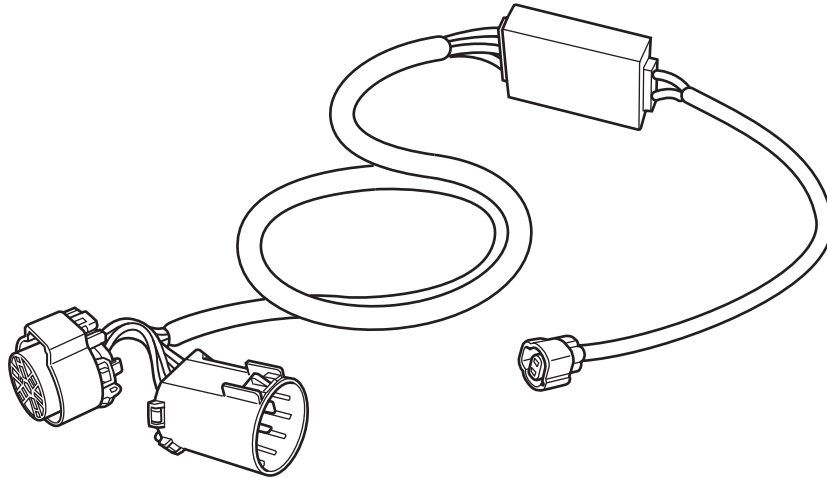

1X

### CABLE TIE

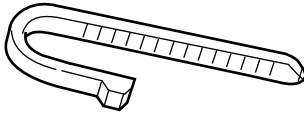

8X

### CABLE TIE BASE

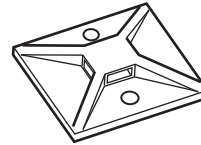

2X



### IMPORTANT

- ▼ BE SURE THE VEHICLE IS TURNED OFF FOR THIS INSTALLATION.
- ▼ READ THROUGH THE ENTIRE PROCEDURE BEFORE STARTING AND FOLLOW THE STEPS CAREFULLY TO ENSURE THE THIRD BRAKE LIGHT WILL FUNCTION PROPERLY.
- ▼ USE A TEST LIGHT TO CHECK FOR SUCCESSFUL INSTALLATION.

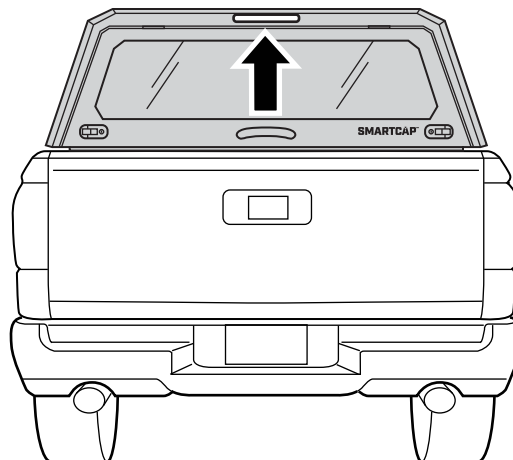

## STEP 36

REMOVE THE BOLTS HOLDING THE DRIVER SIDE TAILLIGHT ASSEMBLY.

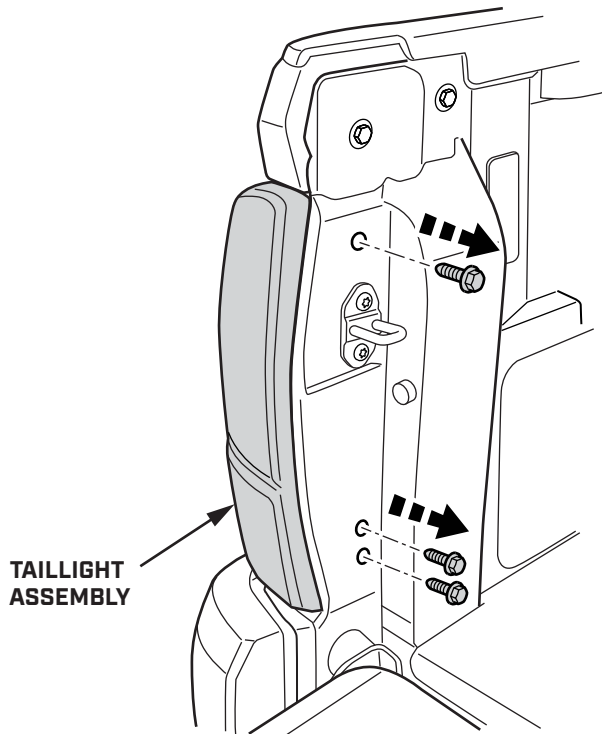

## STEP 37

PLACE THE TAILLIGHT ASSEMBLY CAREFULLY ON THE TAILGATE. DO NOT UNPLUG ANY CONNECTORS.

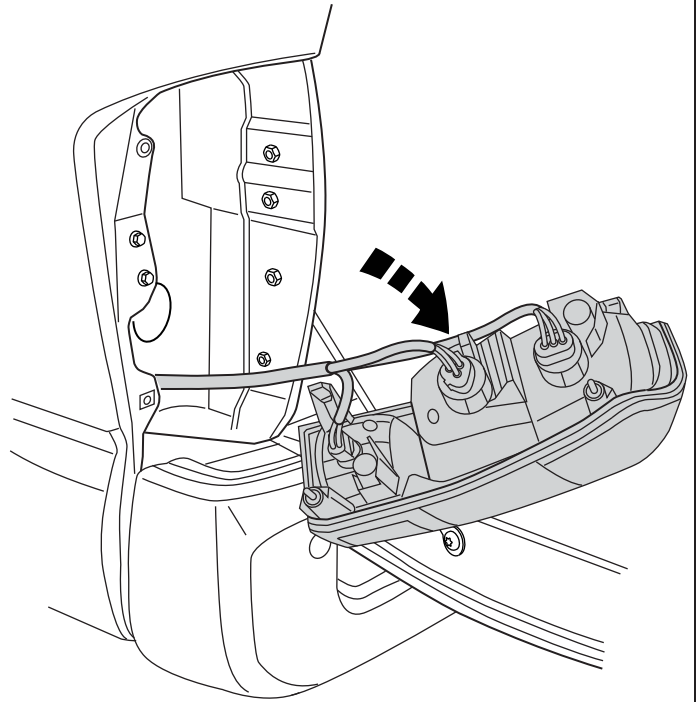

## STEP 38

USING A 3/8 INCH DRILL BIT, DRILL A GUIDE HOLE IN THE LEFT REAR CORNER OF THE TRUCK BED. MAKE SURE THE HOLE IS DRILLED WITHIN A HALF INCH FROM THE BEND IN THE PANEL.

ONCE COMPLETE, USE THE 3/4 INCH DRILL BIT TO BORE OUT THE HOLE.

IF NECESSARY, REMOVE ANY BURRS OR SHARP EDGES WITH A METAL FILE.

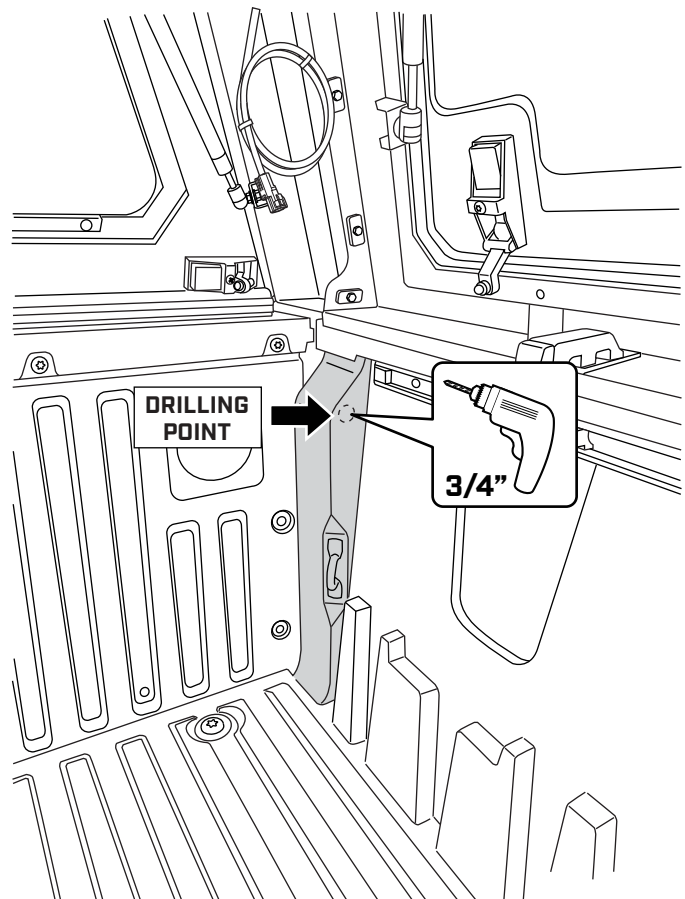

## STEP 39

ROUTE THE THIRD BRAKE LIGHT EXTENSION HARNESS FROM THE INSIDE OF THE CAP AND THROUGH THE 3/4" DRILLED HOLE. CAREFULLY FEED THE HARNESS PAST THE TAILLIGHT CAVITY, ENSURING THAT IT EXTENDS TOWARDS THE REAR BUMPER OF THE TRUCK.

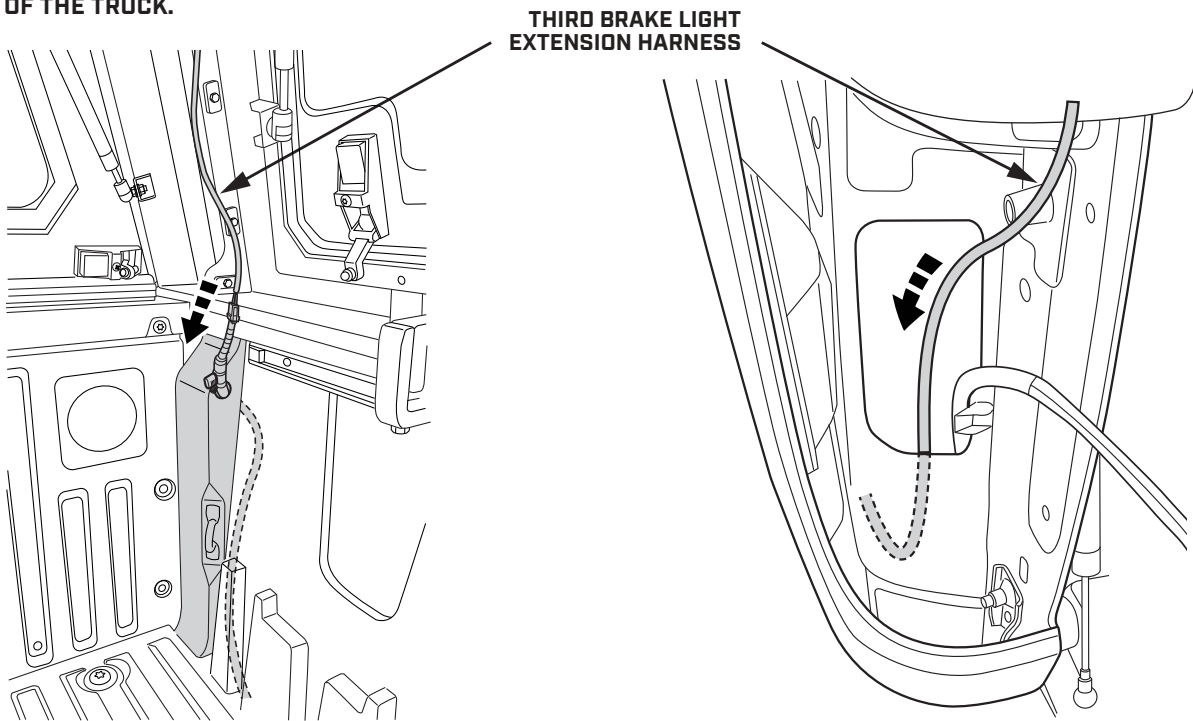

## STEP 40

RETRIEVE THE SUPPLIED T-HARNESS FROM YOUR FITMENT KIT.

CONNECT THE 2-PIN FEMALE PLUG OF THE T-HARNESS INTO THE MALE 2-PIN PLUG OF THE THIRD BRAKE LIGHT EXTENSION HARNESS.

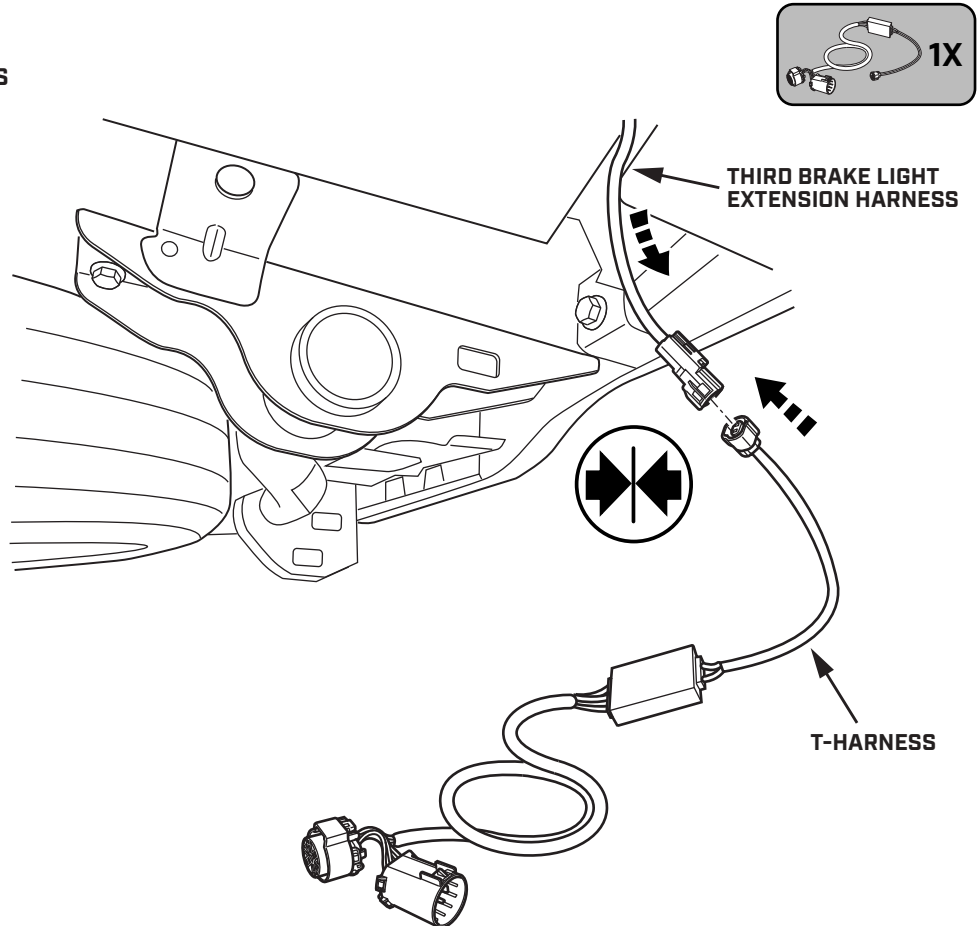

## STEP 41

FROM UNDERNEATH THE VEHICLE, ROUTE THE T-HARNESS ABOVE THE FRAME, ALONG THE INSIDE OF THE REAR BUMPER AND TOWARD THE 7 WAY TRAILER HITCH CONNECTOR NEAR THE TRAILER HITCH.

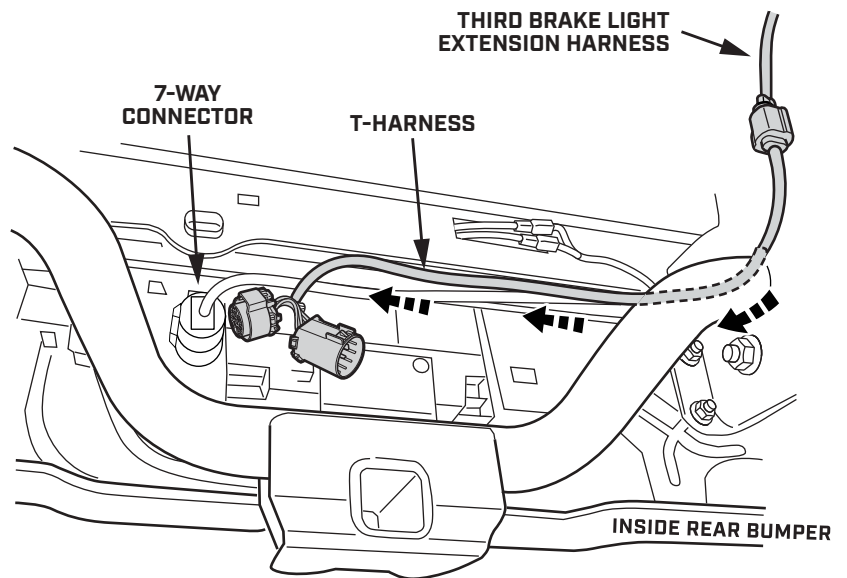

## STEP 42

DISCONNECT THE PLUG FROM THE BACK OF THE 7-WAY CONNECTOR.

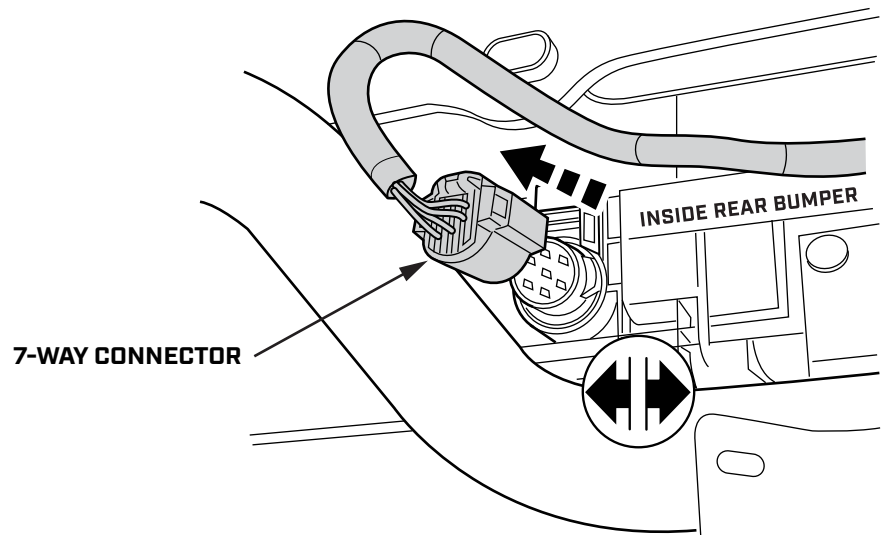

## STEP 43

PLUG THE NEW T-HARNESS INTO THE BACK OF THE 7-WAY CONNECTOR.

CONNECT THE ORIGINAL PLUG INTO THE FEMALE SIDE OF THE T-HARNESS.

BE SURE PLUGS ARE FULLY INSERTED AND LOCKING TABS ARE IN PLACE.

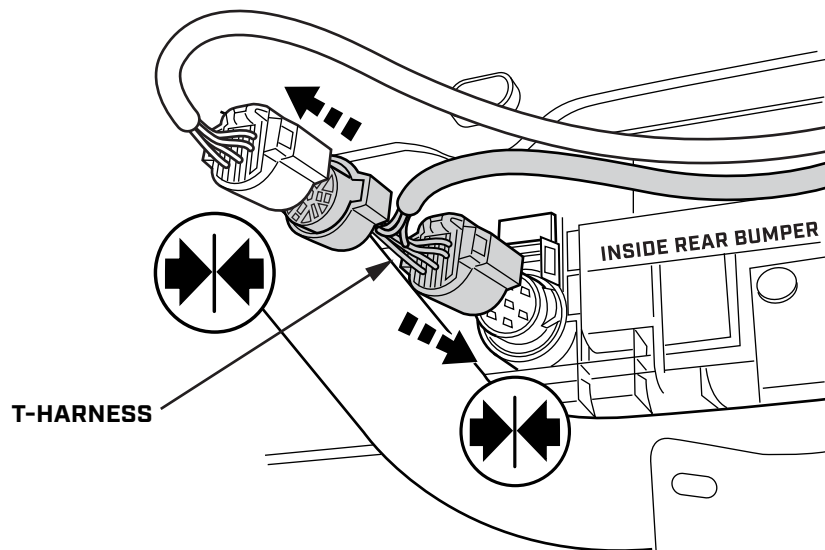

## STEP 44

BUNDLE EXTRA T-HARNESS LENGTH IN THE TAILLIGHT CAVITY AND SECURE WITH CABLE TIES.

REINSTALL THE TAILLIGHT ASSEMBLY.

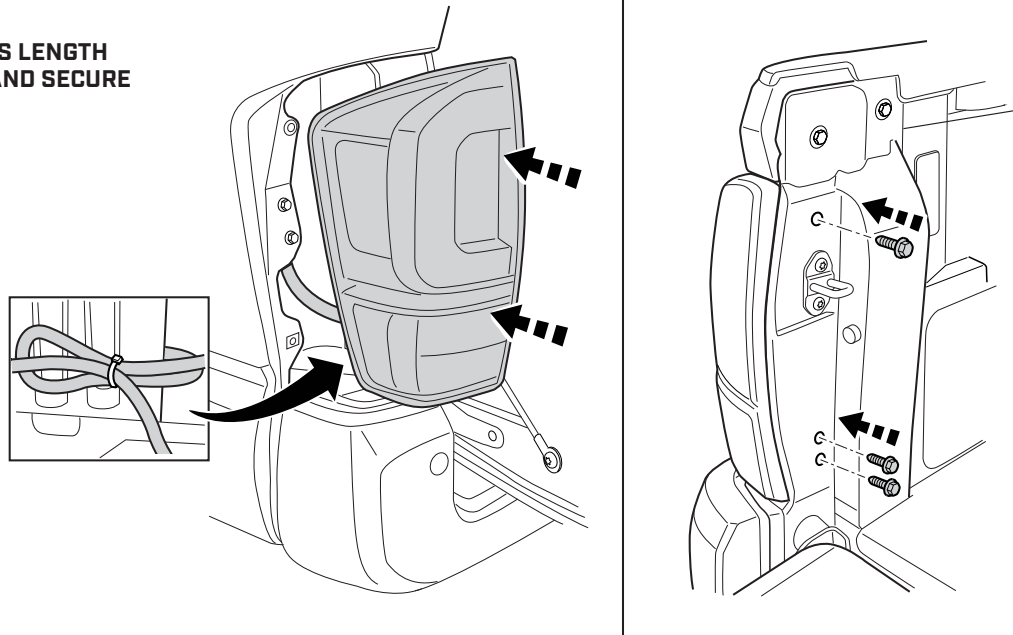

## STEP 45



### TEST YOUR BRAKE LIGHTS & TURN SIGNALS

- ▼ START THE TRUCK. SOME MODELS MAY TAKE UP TO 30 SECONDS FOR THE VEHICLE TO DETECT THE NEW CONNECTION.
- ▼ CHECK THE BRAKE LIGHTS AND TURN SIGNALS TO BE SURE THEY ARE FUNCTIONING PROPERLY.
- ▼ ONCE YOU HAVE CONFIRMED THAT THE LIGHTS ARE WORKING CORRECTLY, SECURE THE HARNESS WITH CABLE TIES.
- ▼ BE SURE NOT TO INTERFERE WITH ANY MOVING PARTS ON THE VEHICLE.
- ▼ YOUR CAP INSTALLATION IS COMPLETE.

**WARNING: SOME VEHICLES MAY SHOW A "DISCONNECTED TRAILER" ERROR. IF THIS OCCURS AND YOUR TRUCK IS EQUIPPED WITH VEHICLE TOWING SOFTWARE, NAVIGATE THE CONTROLS TO MANUALLY ENABLE POWER TO THE 7-WAY CONNECTOR. THIS CAN APPEAR AS "ENABLE AUXILIARY" OR "ENABLE TRAILER." IF CHMSL DOES NOT WORK, SHUT OFF THE VEHICLE. WAIT 10 SECONDS AND RESTART. WAIT AN ADDITIONAL 10 SECONDS FOR THE VEHICLE TO DETECT CHMSL.**

**IMPORTANT: WHEN ATTACHING A TRAILER, ALWAYS TEST THE TRAILER LIGHT FUNCTIONALITY WHILE USING THIS SYSTEM.**



THANKS FOR YOUR PURCHASE.

PLEASE LET US KNOW IF YOU HAVE ANY QUESTIONS.

SUPPORT.NA@SMARTCAP.COM - NORTH AMERICA

SUPPORT.SA@SMARTCAP.COM - REST OF WORLD

SMARTCAP.COM

