

SMARTCAP®

INSTRUCTION GUIDE

TOYOTA TACOMA EDITION

2016-2023

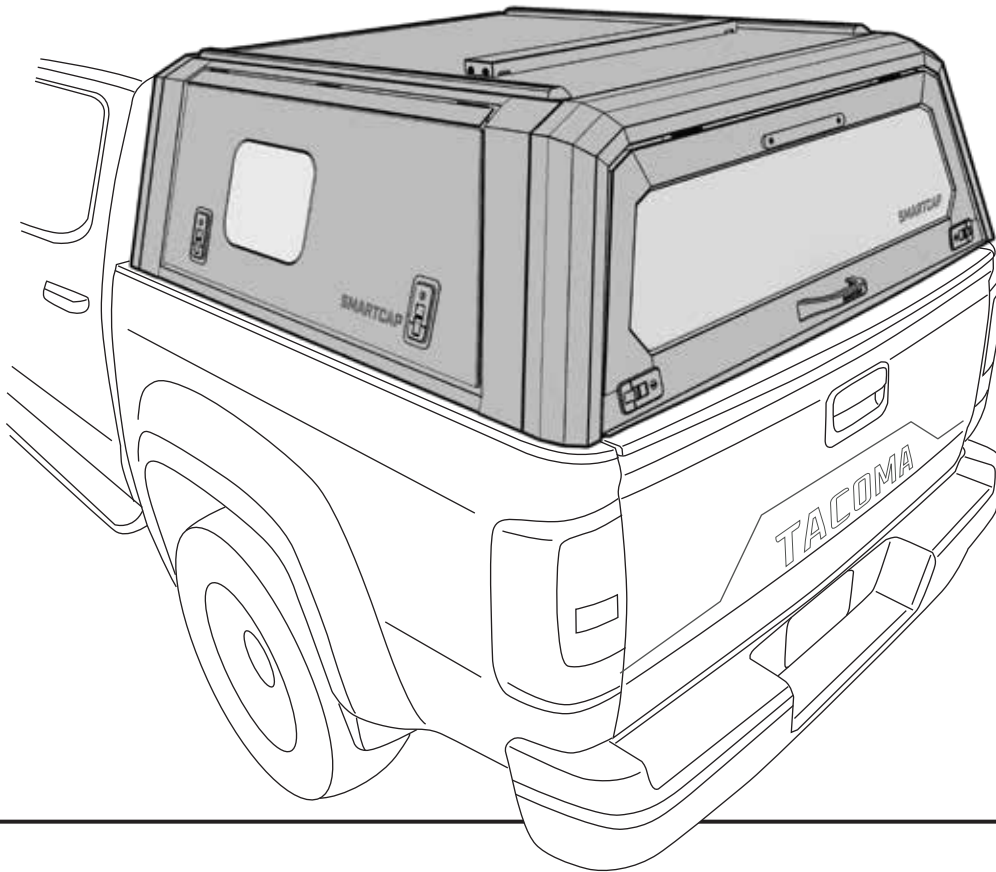

- ▼ **PREPARE A CLEAN WORK AREA.**
- ▼ **WE RECOMMEND A MINIMUM OF 2 PEOPLE FOR ASSEMBLY.**
- ▼ **ENSURE THE REQUIRED TOOLS ARE PRESENT AND ALL HARDWARE CONTENTS ARE ACCOUNTED FOR.**
- ▼ **NEVER USE ACETONE OR THINNERS ON PAINTED PARTS.**
- ▼ **READ THROUGH THE ENTIRE INSTRUCTION GUIDE BEFORE STARTING THIS PROCEDURE AND FOLLOW THE STEPS CAREFULLY TO AVOID ANY DAMAGE TO THE COMPONENTS OR THE VEHICLE.**

SMARTCAP.COM - SUPPORT.NA@SMARTCAP.COM - NORTH AMERICA



I-SHEET-NA-TA2

TOOLS REQUIRED

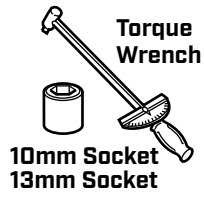
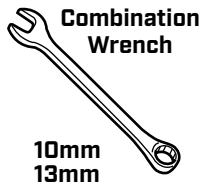
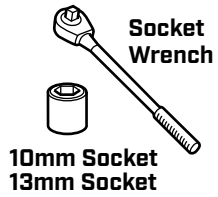

IMPORTANT

- ▼ USE ONLY THE TOOLS RECOMMENDED ABOVE.
- ▼ USE ONLY THE HARDWARE PROVIDED IN THIS KIT.
- ▼ ASSISTANCE WILL BE NEEDED FOR THIS INSTALLATION.
FOUR PEOPLE ARE RECOMMENDED TO LIFT THE SMARTCAP ONTO THE VEHICLE.
- ▼ AVOID PINCHING OR CRUSHING HANDS AND FINGERS.
- ▼ INSPECT ALL KIT COMPONENTS FOR DAMAGE BEFORE ASSEMBLY.
- ▼ NEVER USE ACETONE OR THINNERS ON PAINTED PARTS.

COMPONENTS

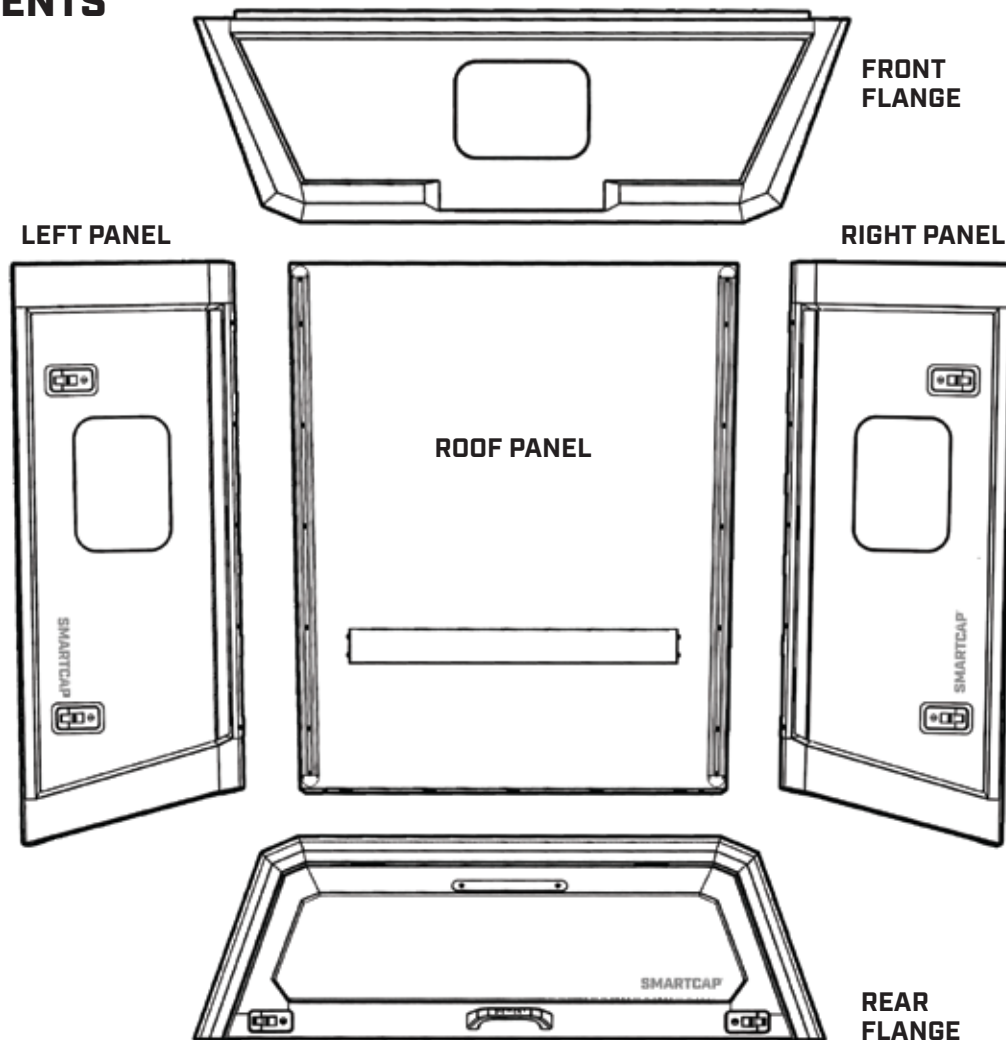

I-SHEET-NA-TA2

ASSEMBLY HARDWARE

FITMENT KIT

M6 BOLT

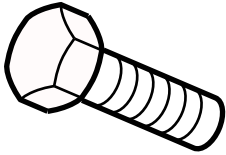

30X

**FASTENER
BLOCK CLAMP**

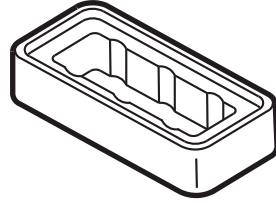

30X

**FASTENER BLOCK
LOAD SPREADER**

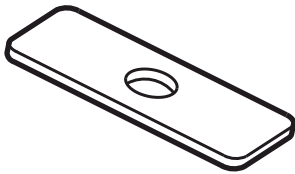

30X

**FASTENER
BLOCK**

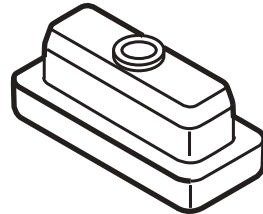

30X

M6 LOCK WASHER

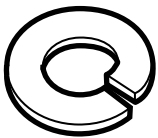

30X

D - RUBBER



1X

SPARE PARTS

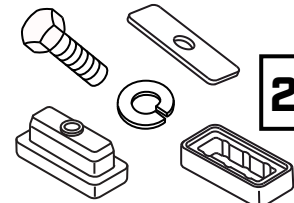

2X

PRE-FASTENED TO ROOF PANEL

**M6
FENDER
WASHER**

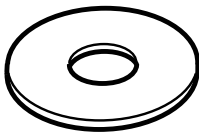

10X

SHORT BED

12X

STANDARD BED

**M6
LOCK
NUT**

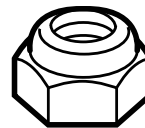

10X

SHORT BED

12X

STANDARD BED

STEP 1



IMPORTANT

2 PERSON JOB



- ▼ BE SURE TO REMOVE ALL FIVE PANELS FROM THEIR PACKAGING AND INSPECT THE PAINTED SURFACES PRIOR TO ASSEMBLY, AS SMARTCAP WILL NOT ACCEPT PAINT DAMAGE WARRANTY CLAIMS AFTER ASSEMBLY IS COMPLETED. IF MANUFACTURING IMPERFECTIONS OR SHIPPING DAMAGES ARE FOUND, DO NOT CONTINUE WITH THE ASSEMBLY PROCESS AND CONTACT SUPPORT.NA@SMARTCAP.COM.

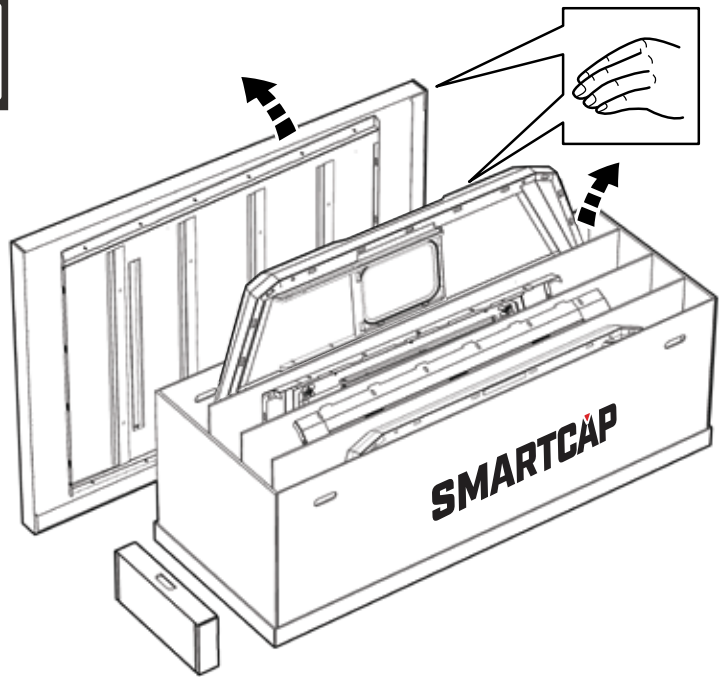

STEP 2

PLACE THE ROOF PANEL WHERE YOU PLAN TO ASSEMBLE THE CAP. REMOVE THE LID FROM THE PACKAGING AND PLACE IT NEXT TO THE ROOF PANEL.

LOGO SIDE UP

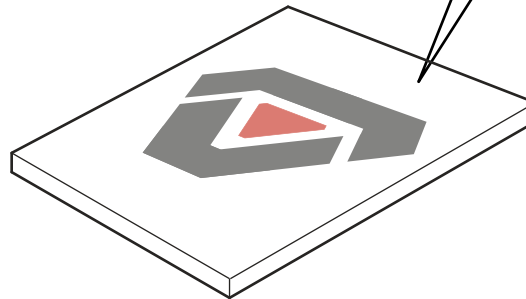

USE LID AS WORK SURFACE

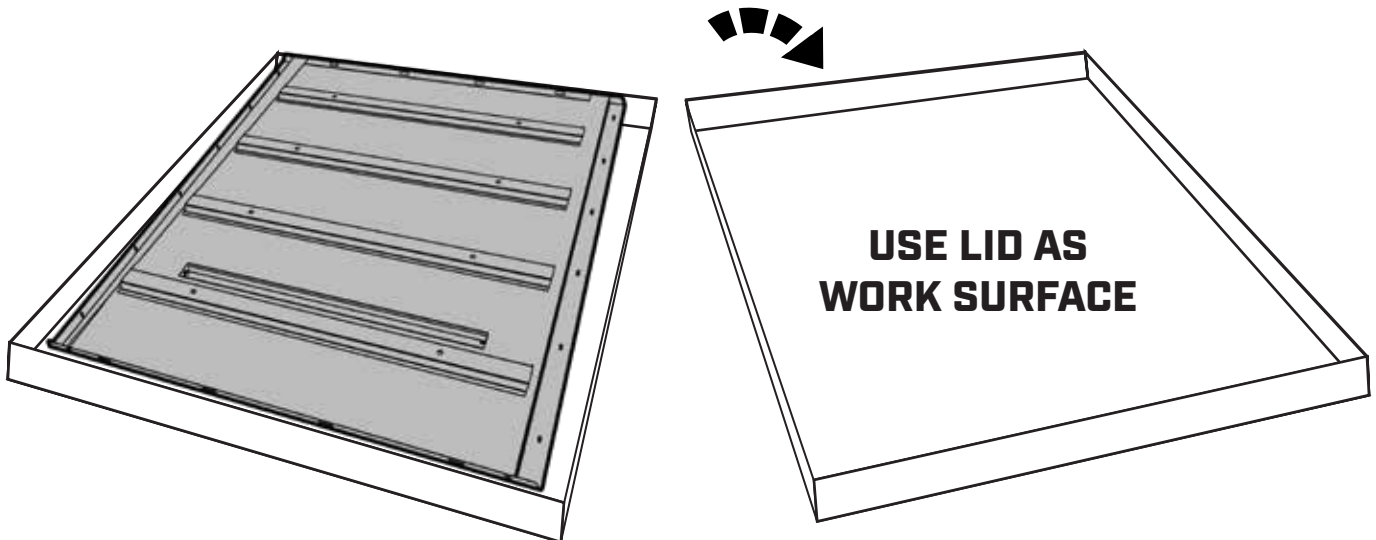

I-SHEET-NA-TA2

STEP 3

USE A 10MM COMBINATION WRENCH TO REMOVE ALL HARDWARE FROM THE ROOF PANEL AND SAVE FOR REUSE.



AIR VENT INDICATES REAR

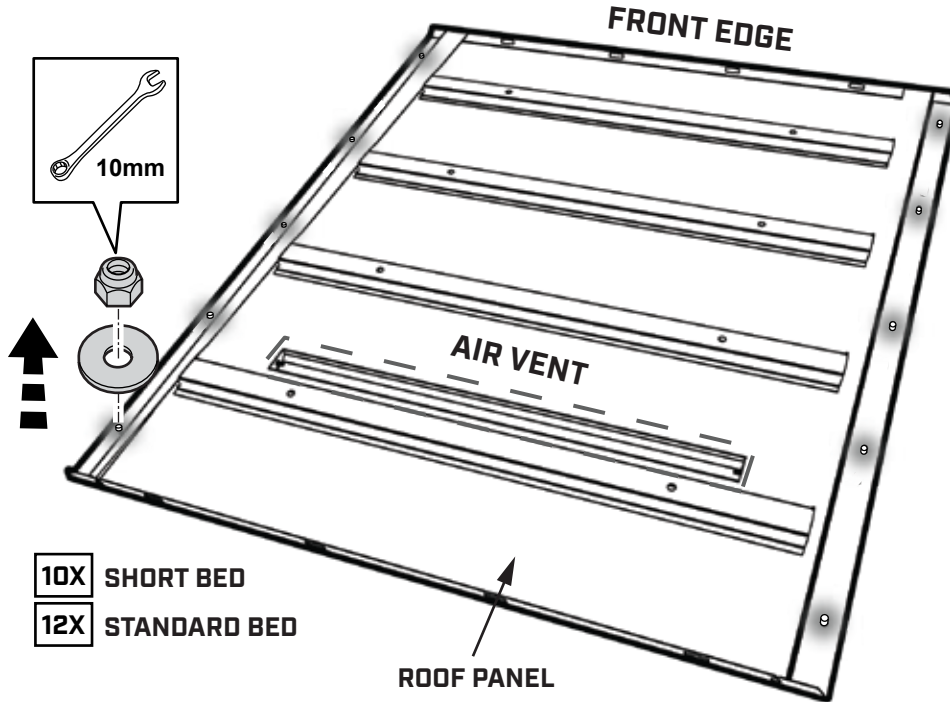

STEP 4

LOCATE THE RIGHT PANEL IN THE SMARTCAP PACKAGE AND BRING IT TO YOUR WORK AREA.



THE SLANTED EDGE INDICATES REAR

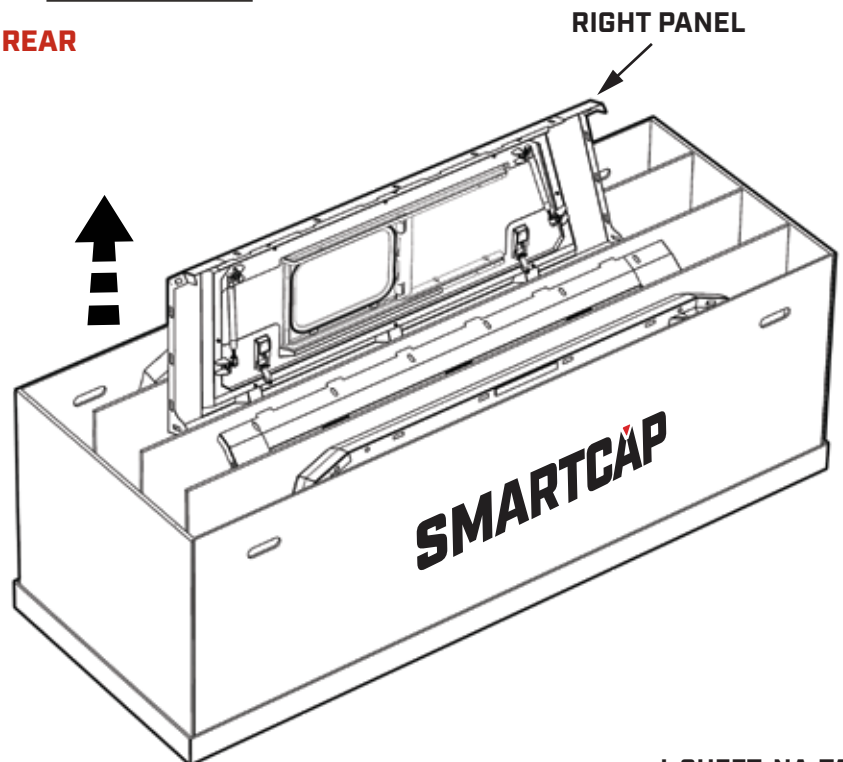

I-SHEET-NA-TA2

STEP 5

INSERT PANEL TABS INTO NARROW SLOTS JUST ABOVE FOAM PADDING ON ROOF PANEL.

TAP FIRMLY WITH PALM OF HAND UNTIL THERE IS A 2-3MM GAP.

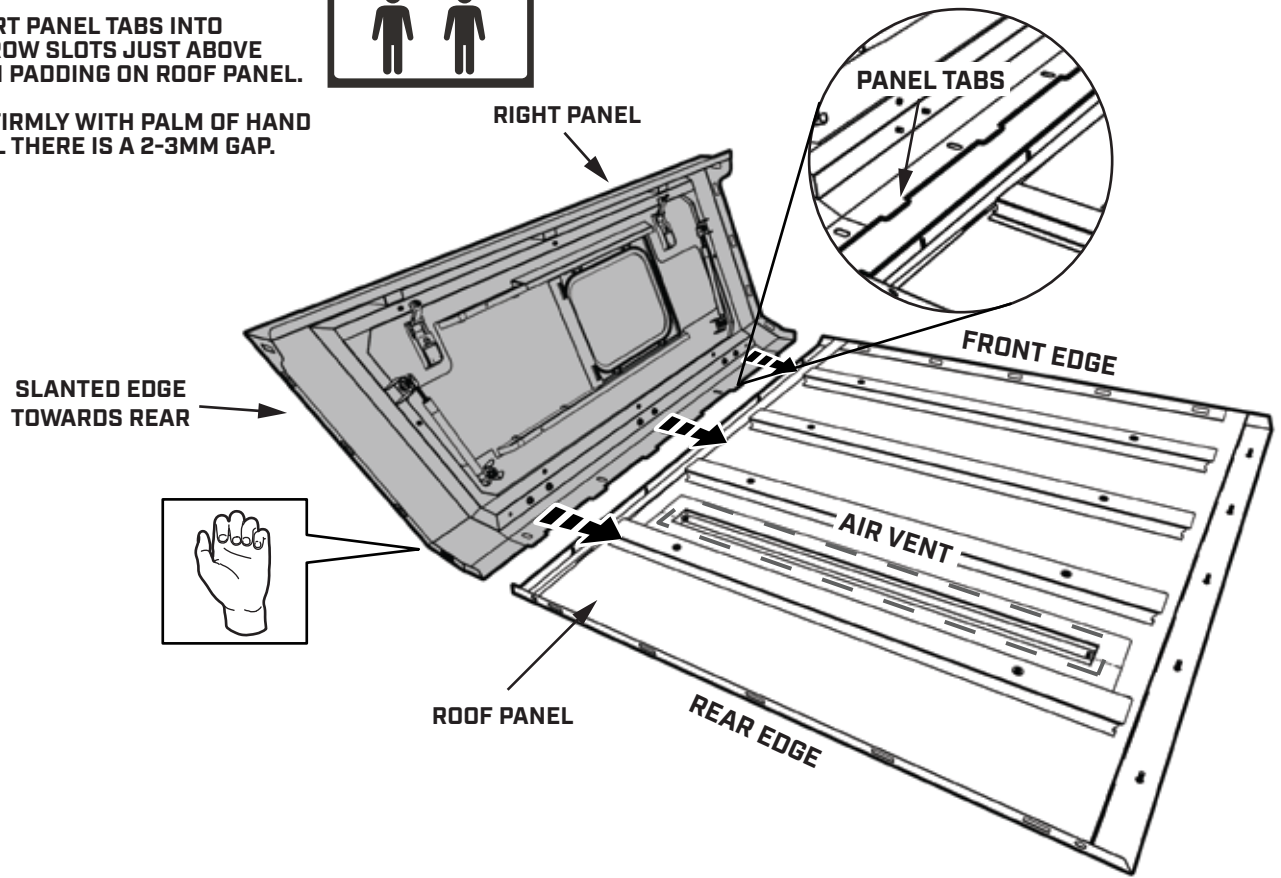

STEP 6

HAND TIGHTEN M6 LOCK NUT WITH M6 FENDER WASHER TO ALL BOLTS.

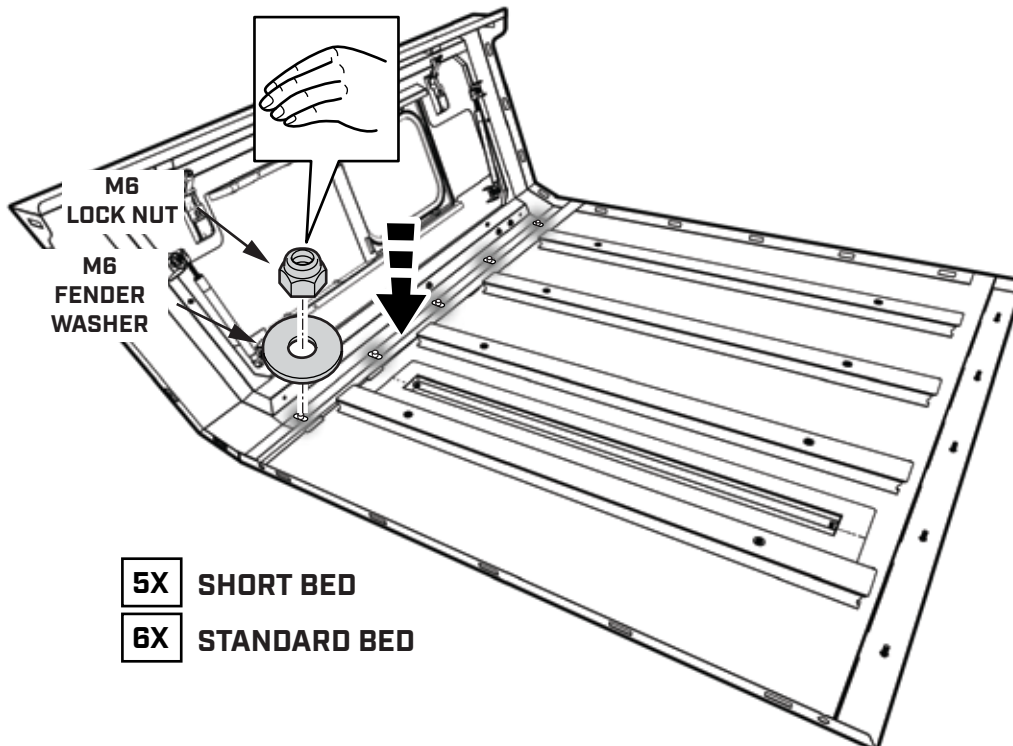
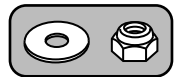

I-SHEET-NA-TA2

STEP 7

LOCATE THE LEFT PANEL IN THE SMARTCAP PACKAGE AND BRING IT TO YOUR WORK AREA.



THE SLANTED EDGE INDICATES REAR

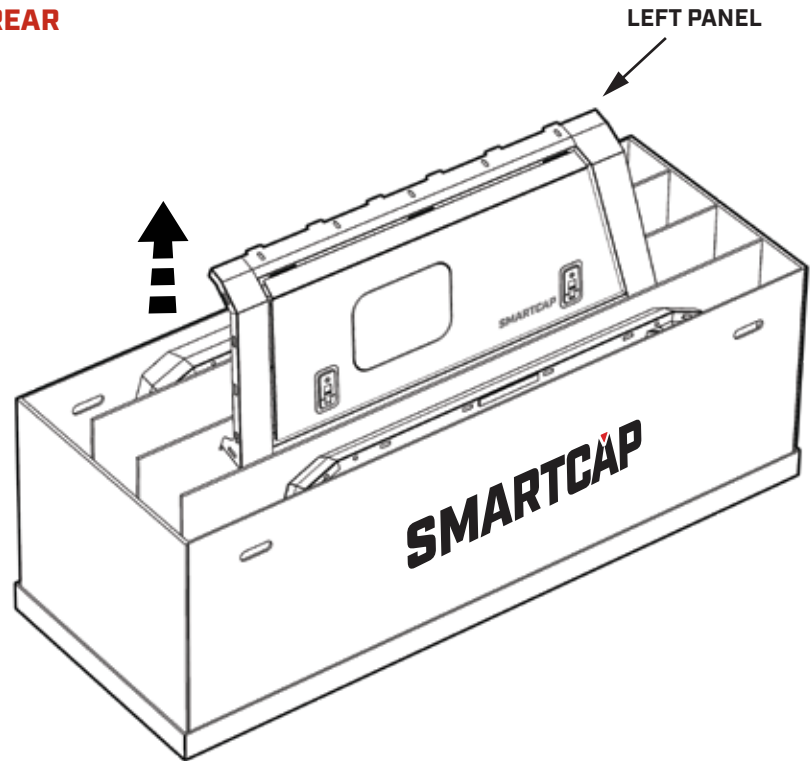
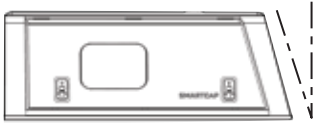

STEP 8

INSERT PANEL TABS INTO NARROW SLOTS JUST ABOVE FOAM PADDING ON ROOF PANEL.



TAP FIRMLY WITH PALM OF HAND UNTIL THERE IS A 2-3MM GAP.

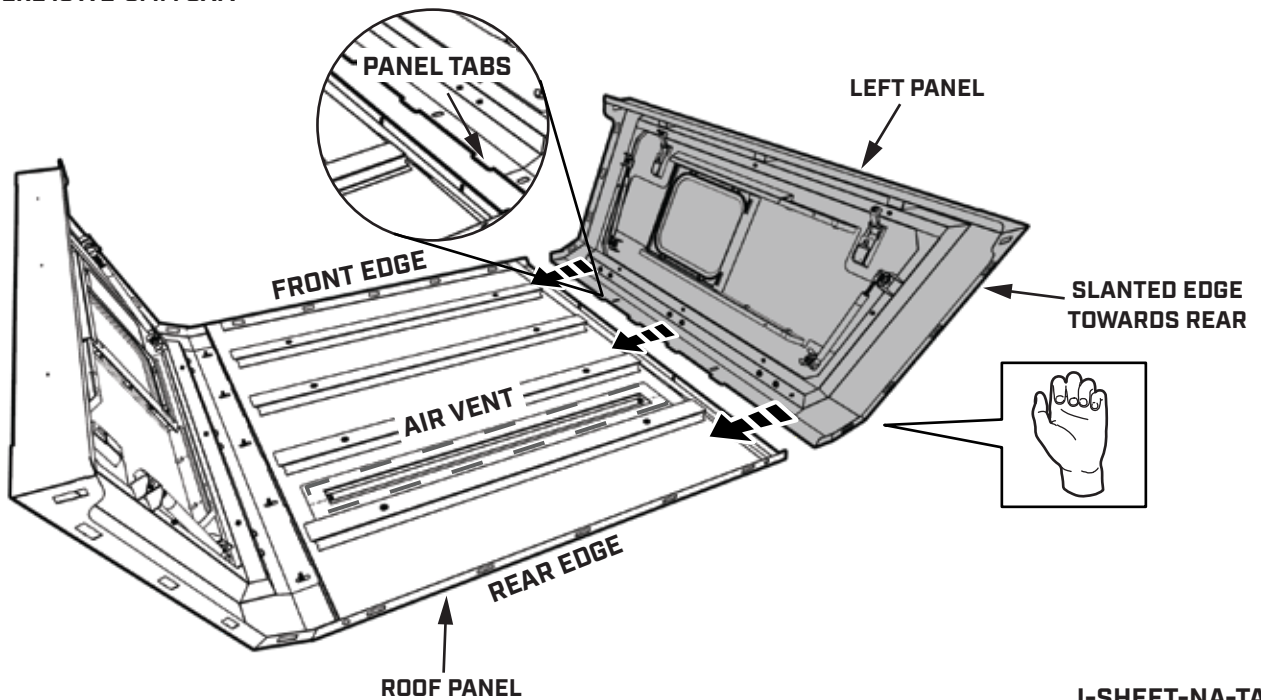

I-SHEET-NA-TA2

STEP 9

HAND TIGHTEN M6 LOCK NUT WITH M6 FENDER WASHER TO ALL BOLTS.

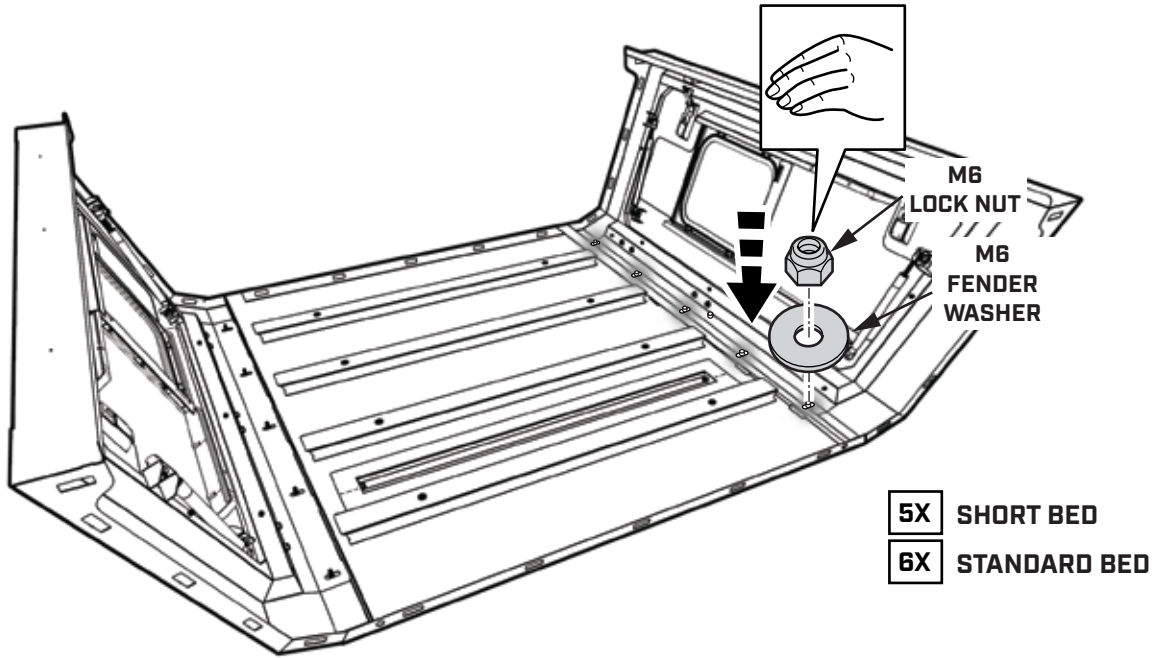
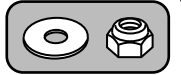

STEP 10

PUSH THE SMARTCAP TO EXPOSE A FEW INCHES OF STYRAFOAM UNDERNEATH THE ROOF PANEL TO PROVIDE SUPPORT FOR THE FRONT FLANGE.

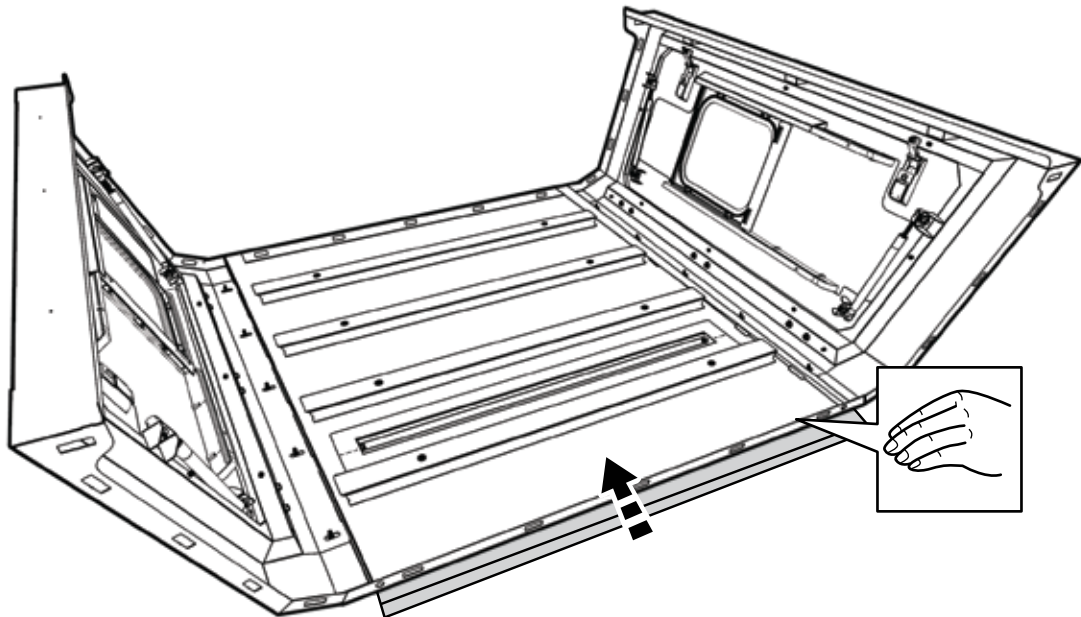

STEP 11

RETRIEVE THE NECESSARY HARDWARE FROM THE FITMENT KIT.

LOCATE THE FRONT FLANGE IN THE SMARTCAP PACKAGE AND BRING IT TO YOUR WORK AREA.

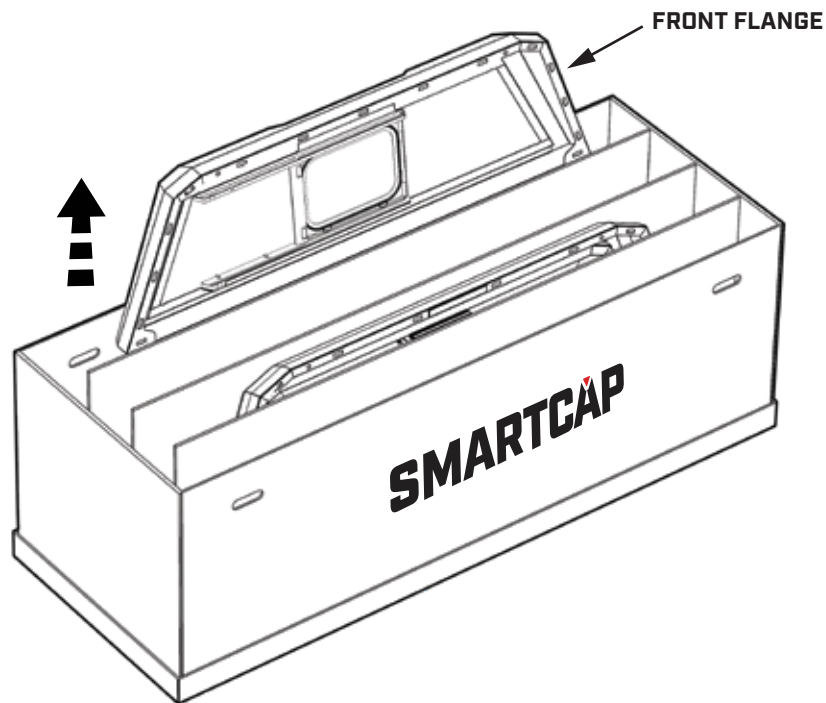
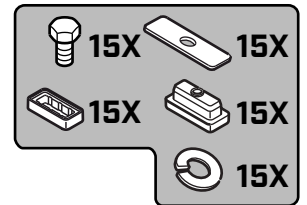

STEP 12

PLACE FRONT FLANGE AS SHOWN BELOW.

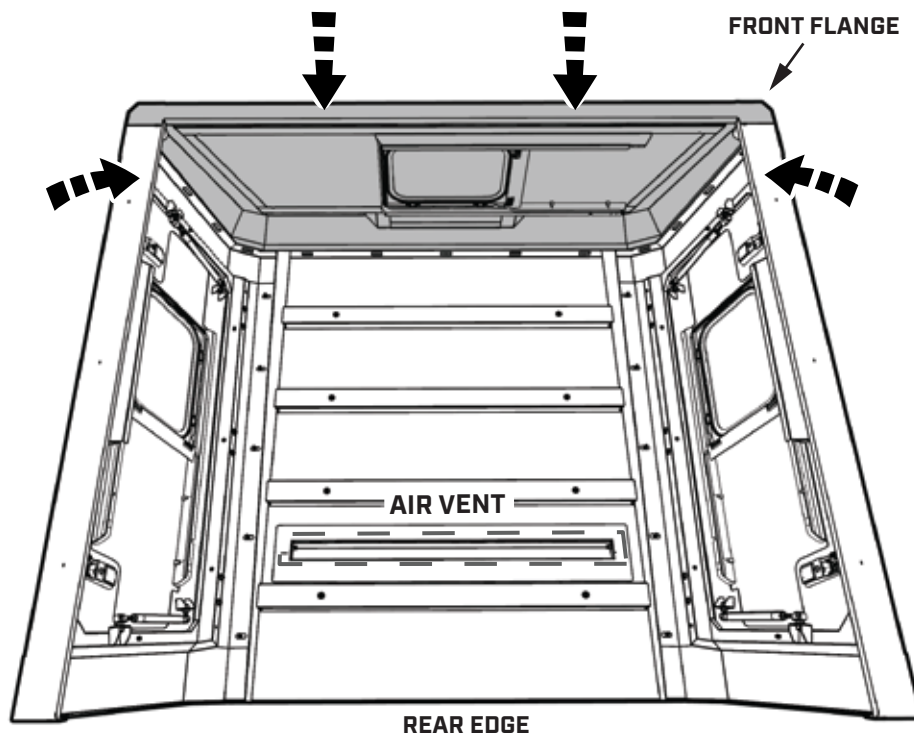

I-SHEET-NA-TA2

STEP 13

INSTALL HARDWARE ALONG FRONT FLANGE WITH M6 BOLT ON INSIDE.

START WITH ASSEMBLING FASTENER BLOCKS 1-5.

ADJUST LEFT AND RIGHT PANELS TO ALIGN FASTENER BLOCKS 6-15 FOR ASSEMBLY.

HAND TIGHTEN IN THE SEQUENCE SHOWN.

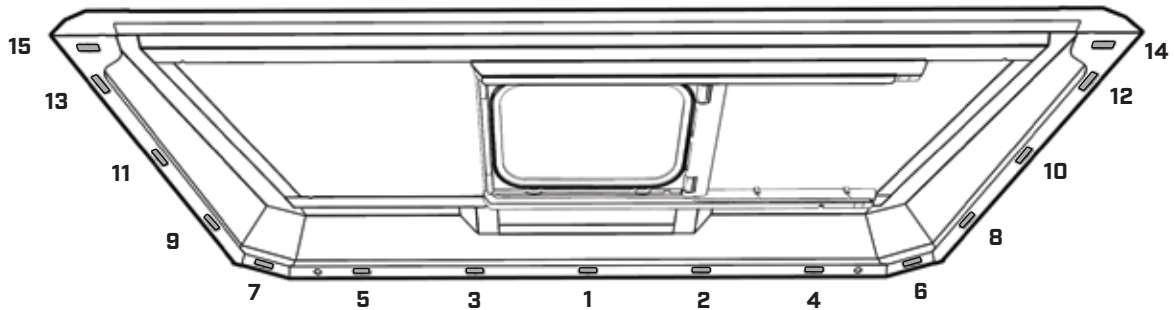
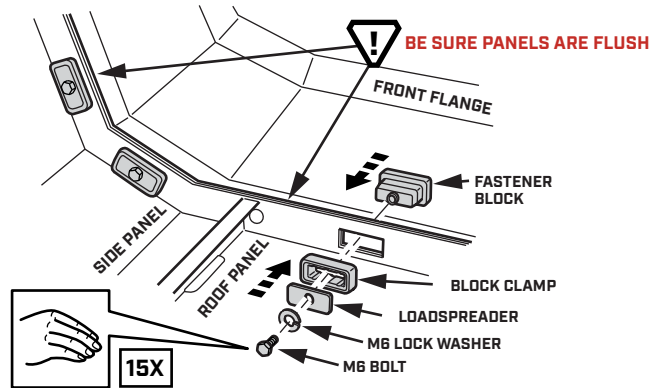

STEP 14

PUSH THE SMARTCAP TO EXPOSE A FEW INCHES OF STYRAFOAM UNDERNEATH THE ROOF PANEL TO PROVIDE SUPPORT FOR THE REAR FLANGE.

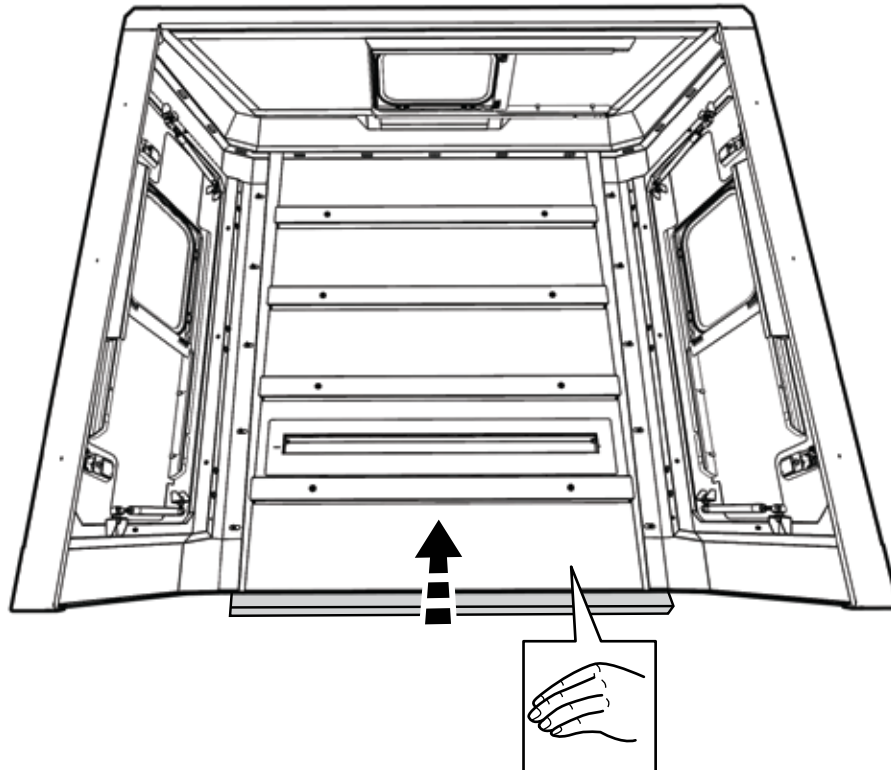

I-SHEET-NA-TA2

STEP 15

RETRIEVE THE NECESSARY HARDWARE FROM THE FITMENT KIT.

LOCATE THE REAR FLANGE IN THE SMARTCAP PACKAGE AND BRING IT TO YOUR WORK AREA.

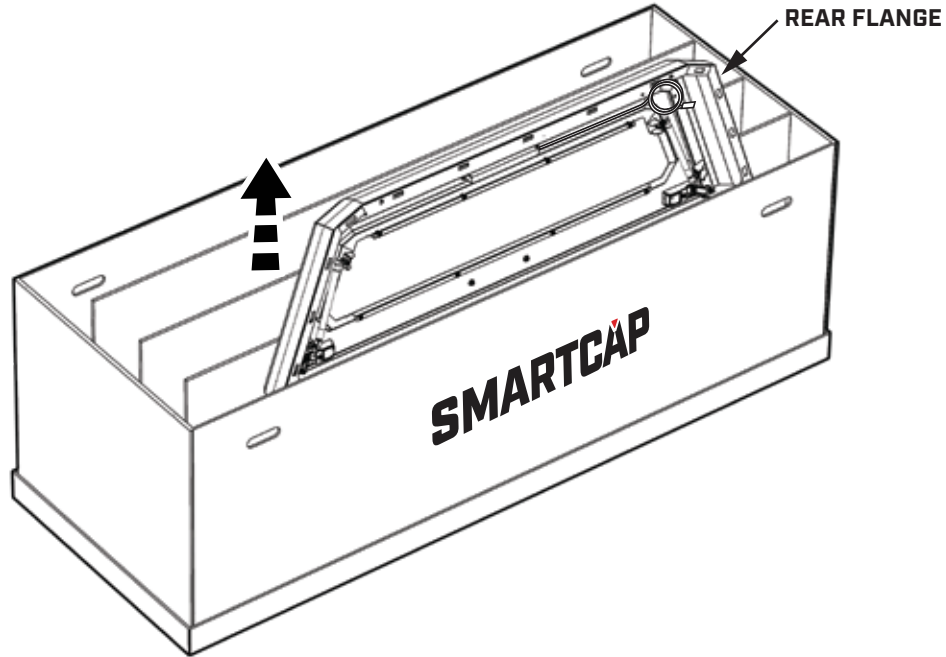
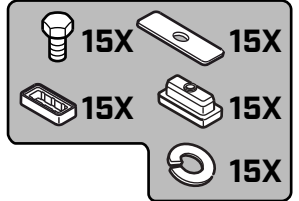
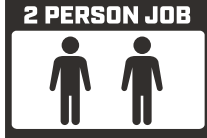

STEP 16

PLACE REAR FLANGE AS SHOWN BELOW.

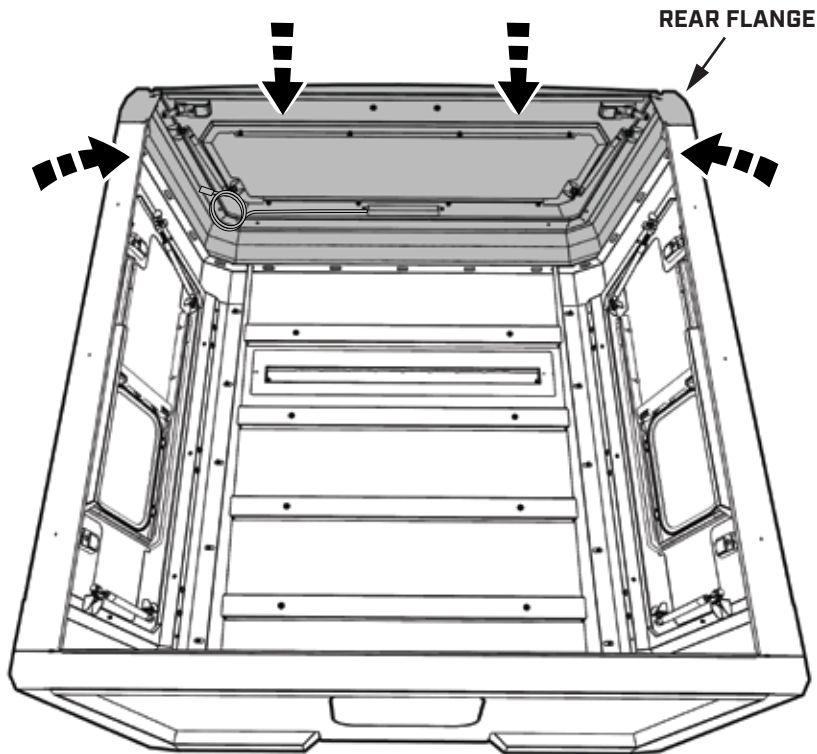

I-SHEET-NA-TA2

STEP 19

A LOCATE THE D-RUBBER RETENTION TAB NEXT TO THE REAR DOOR GASKET.
BEND THE TAB UPWARDS AT A 45 DEGREE ANGLE.

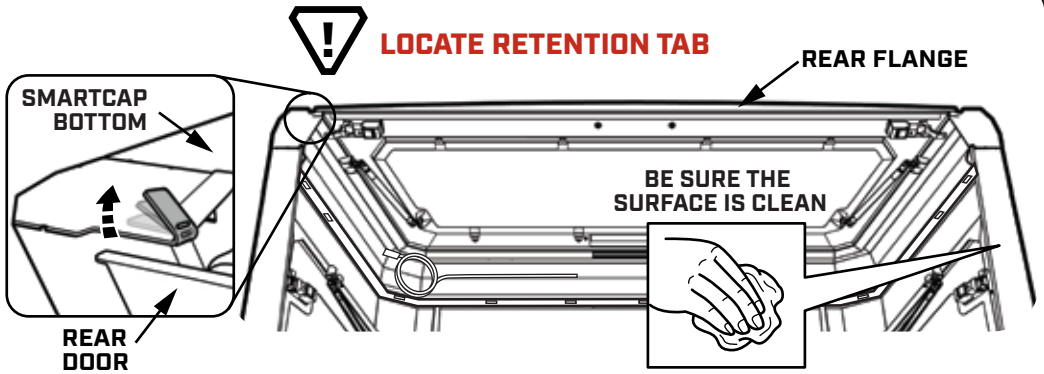

B PEEL AWAY A SMALL PORTION OF THE ADHESIVE BACKING FROM THE D-RUBBER.

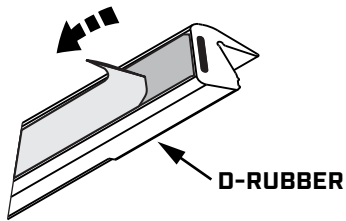

C INSERT THE TAB INTO THE D-RUBBER UNTIL THE D-RUBBER LIGHTLY BUTTS UP AGAINST REAR DOOR GASKET.

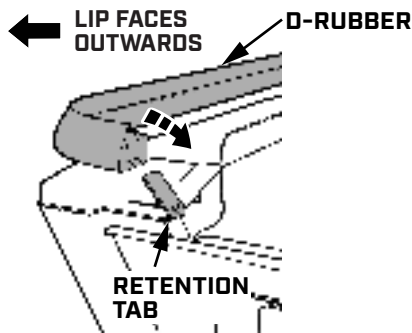

D FIRMLY PUSH THE TAB BACK DOWN TO SECURE THE D-RUBBER IN PLACE.

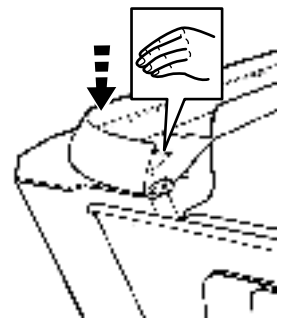

STEP 20

PEEL AWAY ADHESIVE BACKING IN SHORT LENGTHS AS YOU WORK AROUND THE EDGES.

STAY WITHIN 1/8 INCH FROM THE SMARTCAP'S OUTER EDGES.

REMOVE EXCESS WITH A STRAIGHT CUT.

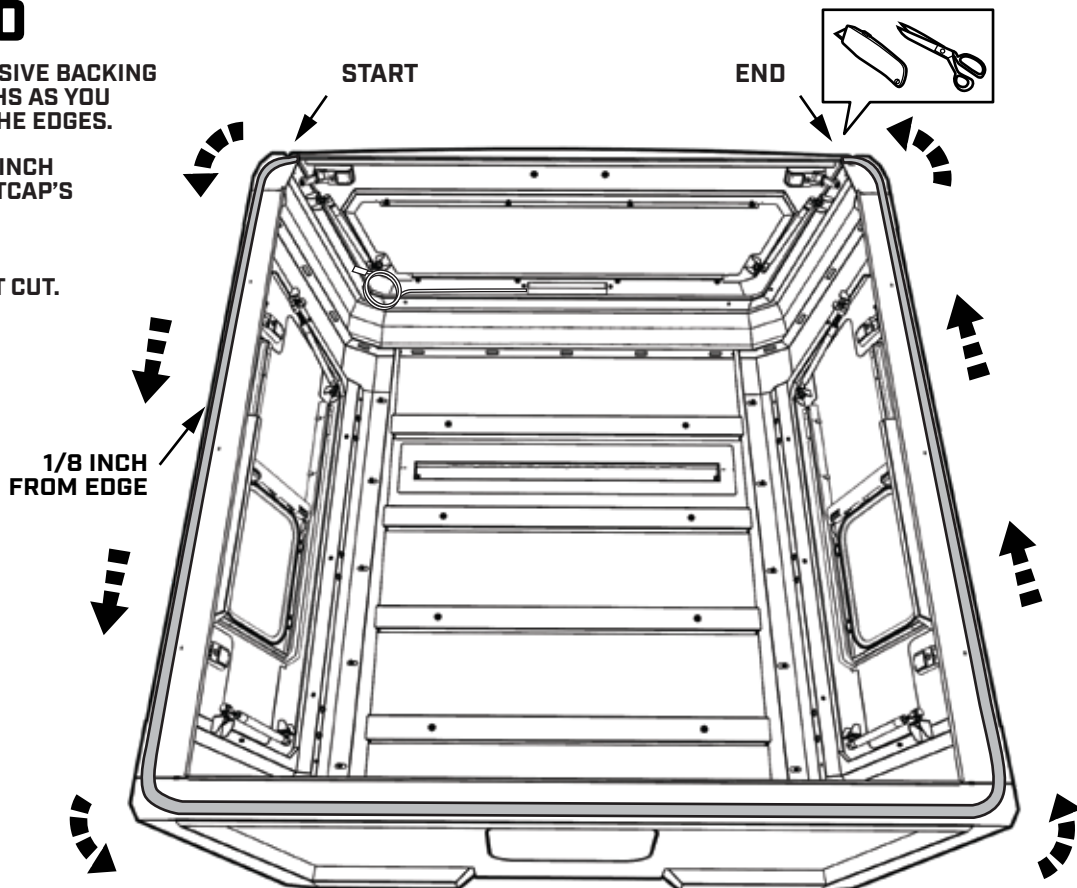

I-SHEET-NA-TA2

INSTALL HARDWARE

THIN RUBBER PAD

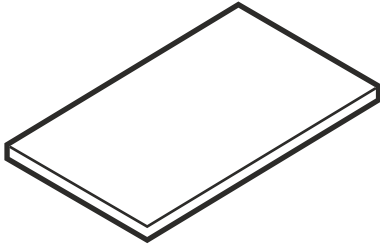

6X

THICK RUBBER PAD

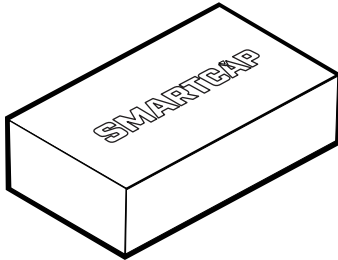

8X

MOUNTING CLAMP

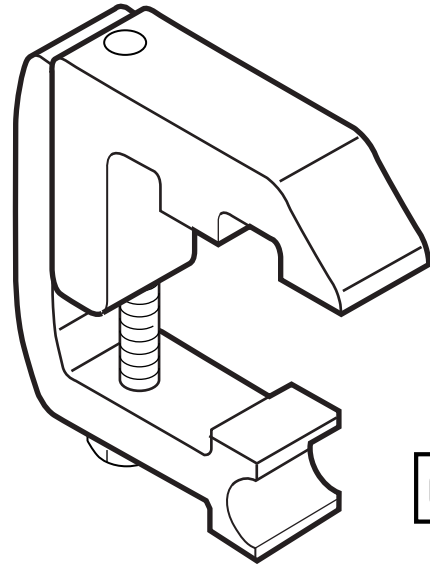

6X

THIRD BRAKE LIGHT HARDWARE

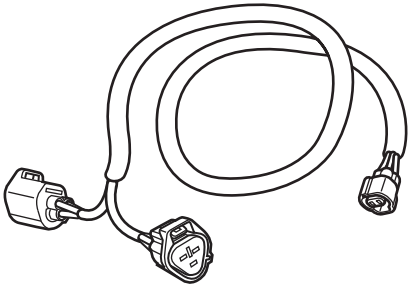

T-HARNESS

1X



IMPORTANT

- ▼ ASSISTANCE WILL BE NEEDED FOR THIS INSTALLATION. FOUR PEOPLE ARE RECOMMENDED TO LIFT THE SMARTCAP ONTO THE VEHICLE.
- ▼ AVOID PINCHING OR CRUSHING HANDS AND FINGERS.
- ▼ BE SURE THE VEHICLE IS TURNED OFF FOR THIS INSTALLATION.
- ▼ READ THROUGH THE ENTIRE PROCEDURE BEFORE STARTING AND FOLLOW THE STEPS CAREFULLY TO ENSURE THE THIRD BRAKE LIGHT WILL FUNCTION PROPERLY.
- ▼ USE A TEST LIGHT TO CHECK FOR SUCCESSFUL INSTALLATION.

I-SHEET-NA-TA2

STEP 21

REMOVE THE ADHESIVE BACKING FROM THE THICK RUBBER PAD.



PLACE THE PADS ALONG THE INSIDE OF THE D-RUBBER AT THE INDICATED LOCATIONS.

PAD PLACEMENT INDICATORS

PLACE EXTRA PAD IN EACH REAR CORNER OF THE CAP

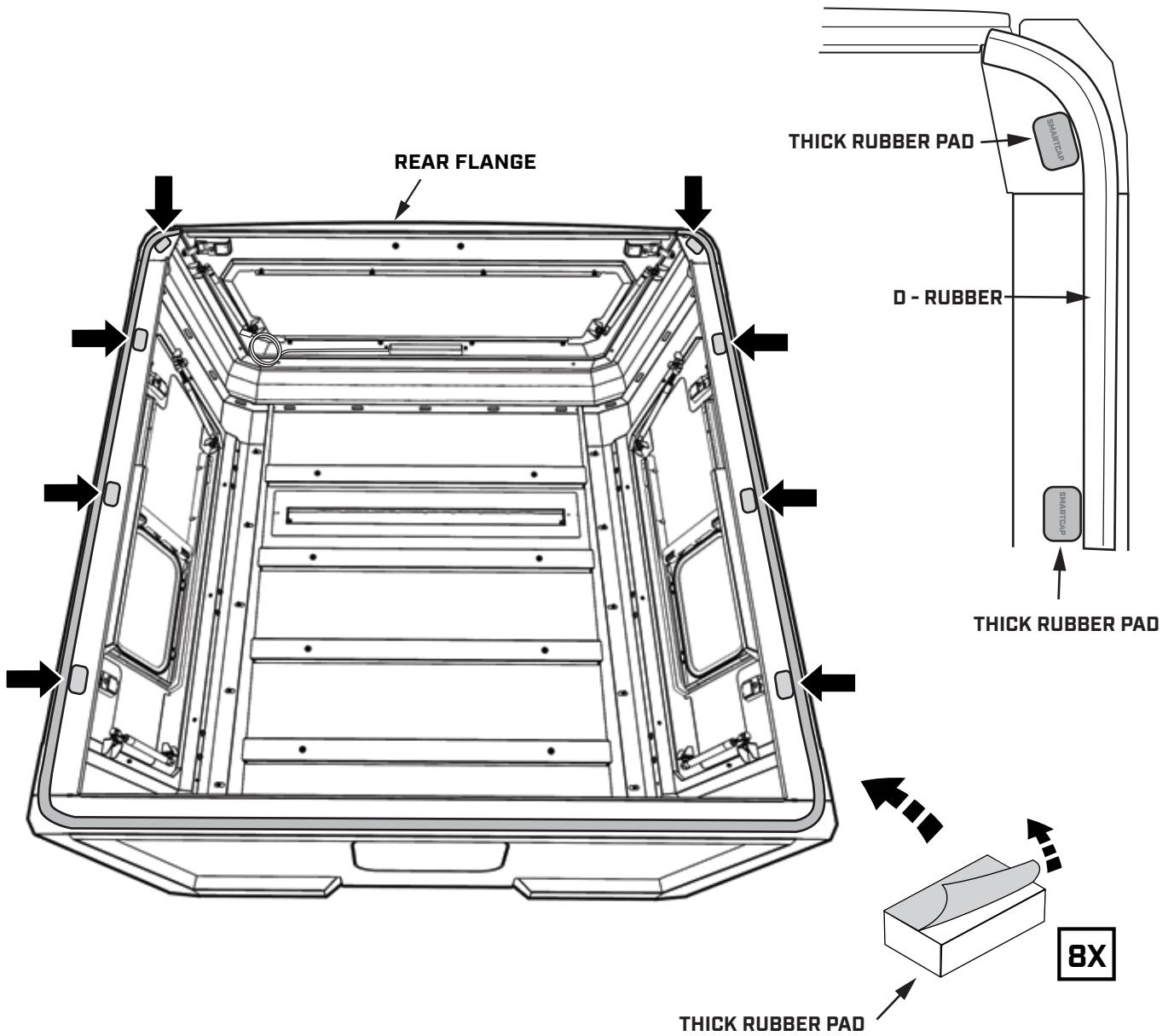
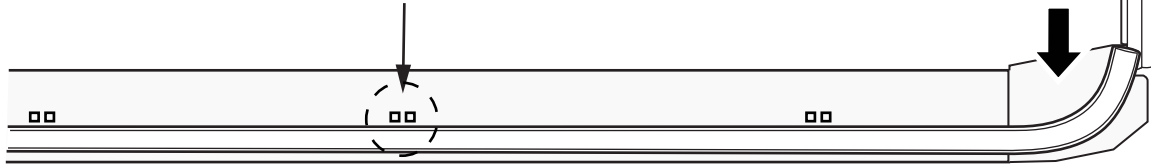

STEP 22

DISCONNECT THE EXTENSION HARNESS FROM THE SMARTCAP.

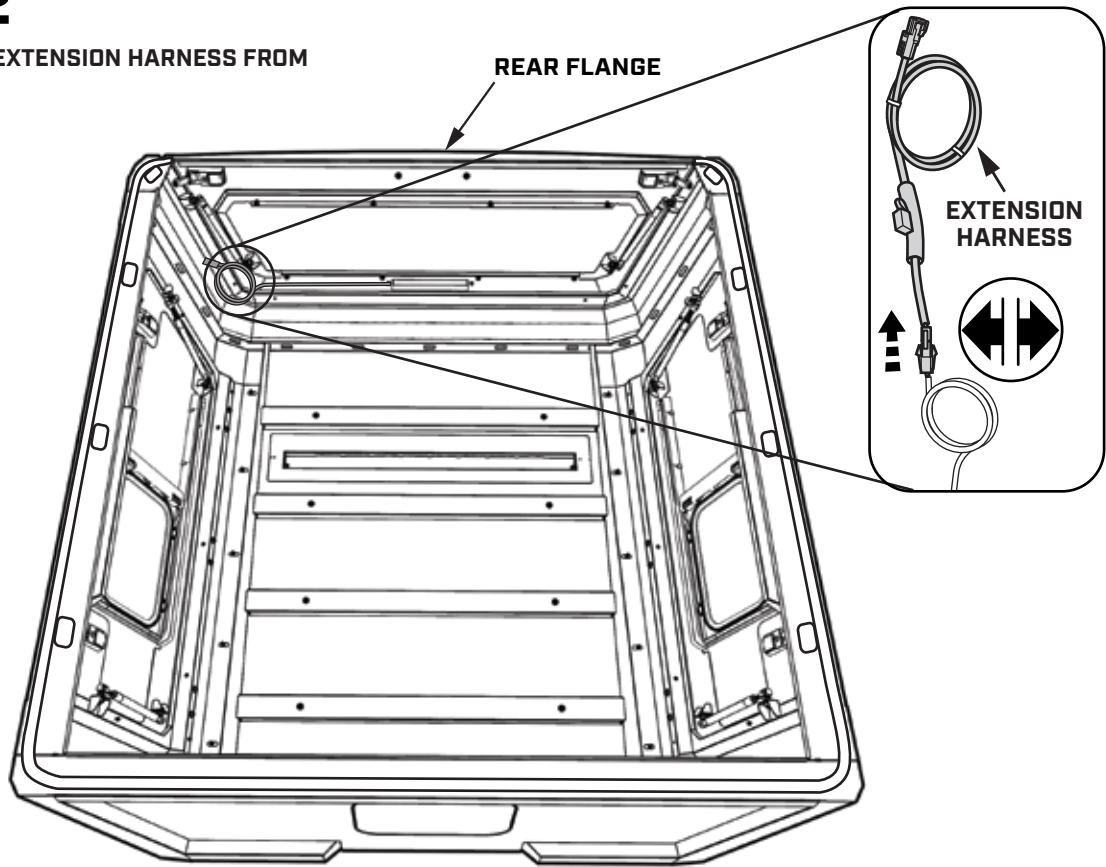

STEP 23

REMOVE THE BOLTS HOLDING THE DRIVER SIDE TAILLIGHT ASSEMBLY.

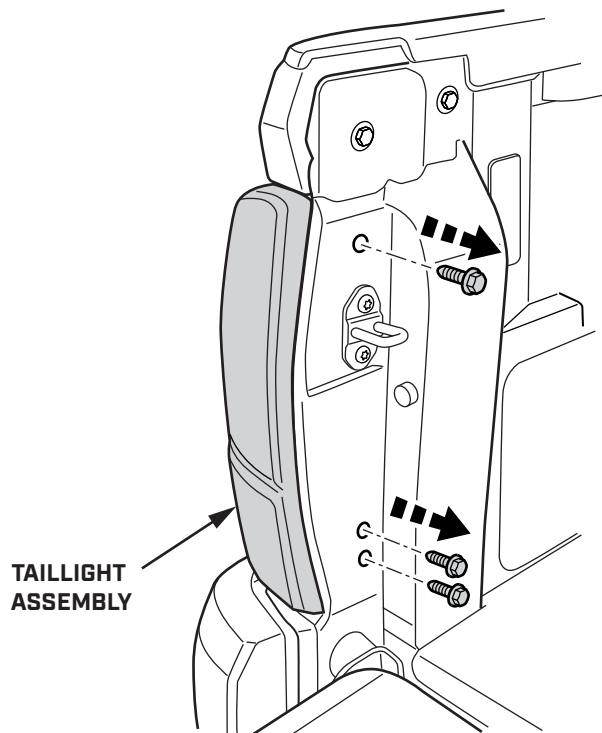

STEP 24

PLACE THE TAILLIGHT ASSEMBLY CAREFULLY ON THE TAILGATE. DO NOT UNPLUG ANY CONNECTORS.

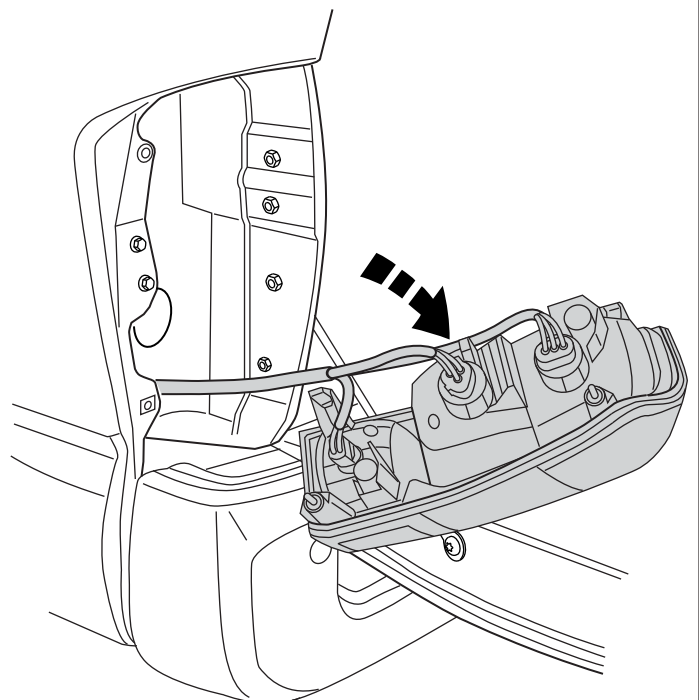

I-SHEET-NA-TA2

STEP 25

CAREFULLY PULL UP ON THE TOP EDGE PANEL OF THE TRUCK BED TO LOCATE THE HOLE IN THE SHEET METAL.

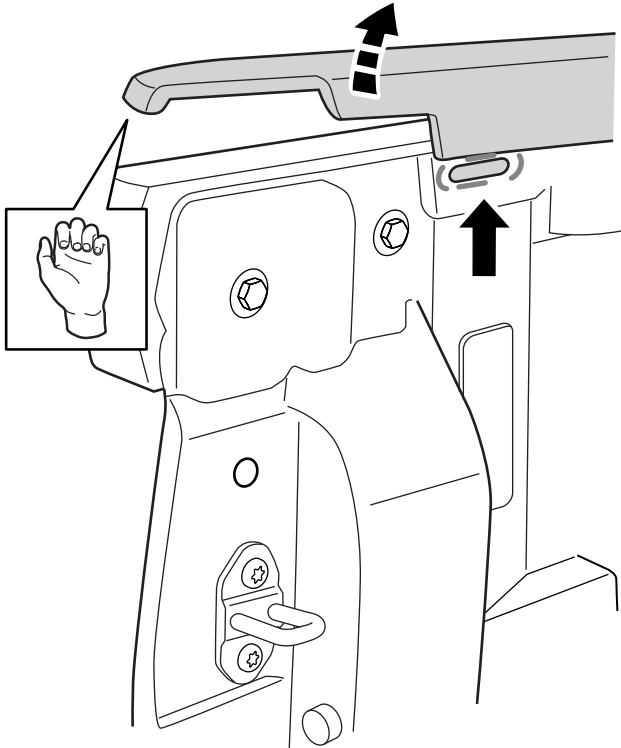

STEP 26

ROUTE THE EXTENSION HARNESS THROUGH THE HOLE AND BACK TOWARDS THE TAILLIGHT OPENING.

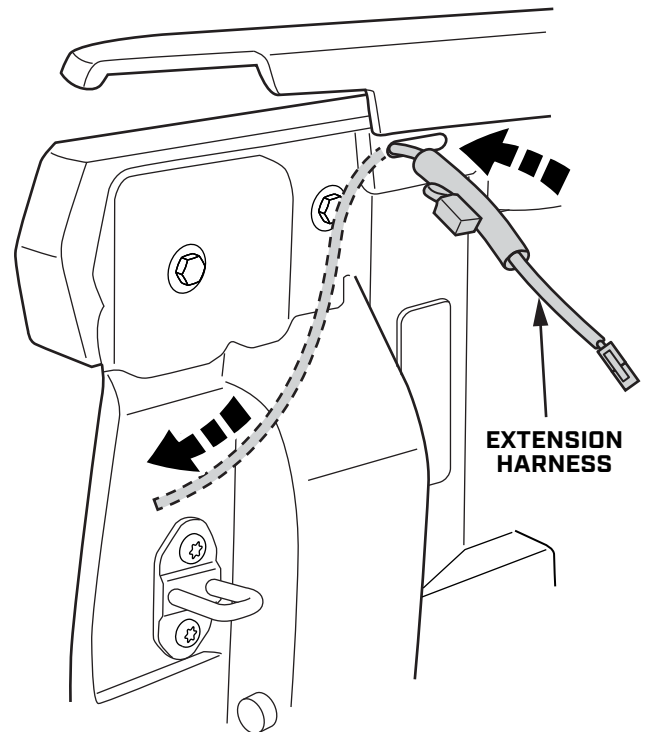

STEP 27

DISCONNECT THE MIDDLE BRAKE LIGHT PLUG AT THE BACK OF THE TAILLIGHT ASSEMBLY.

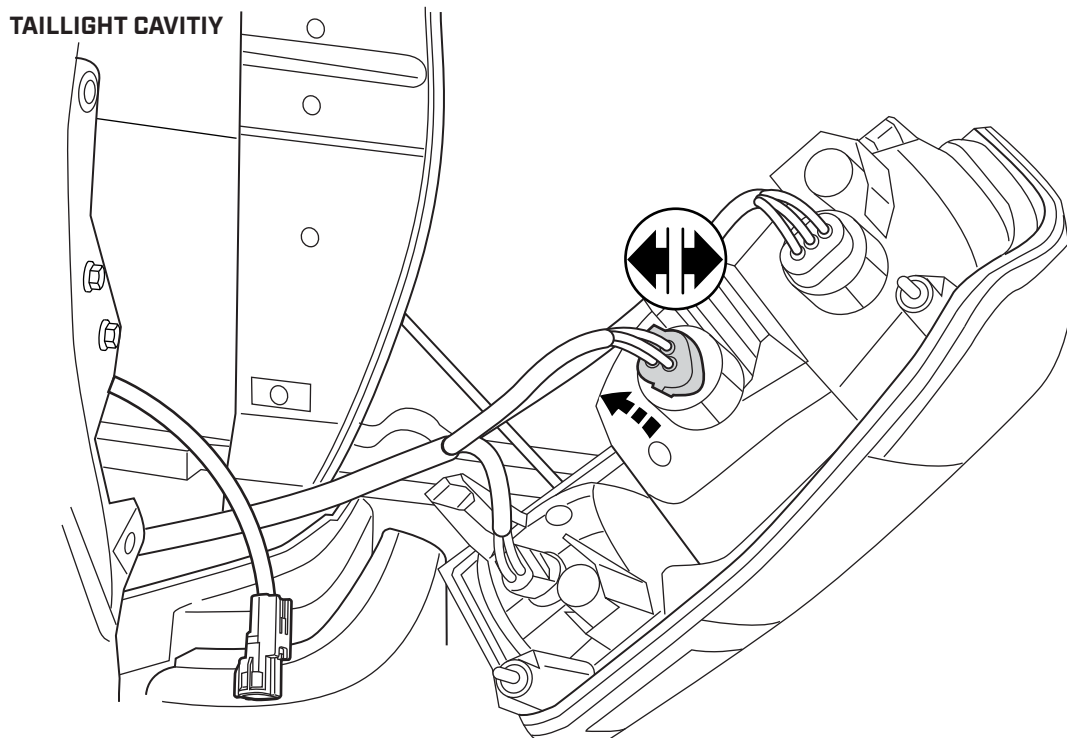

I-SHEET-NA-TA2

STEP 28

CONNECT THE BRAKE LIGHT PLUG INTO THE FEMALE PLUG FROM THE T-HARNESS.

CONNECT THE MALE PLUG FROM THE T-HARNESS INTO THE FEMALE BRAKE LIGHT SOCKET.

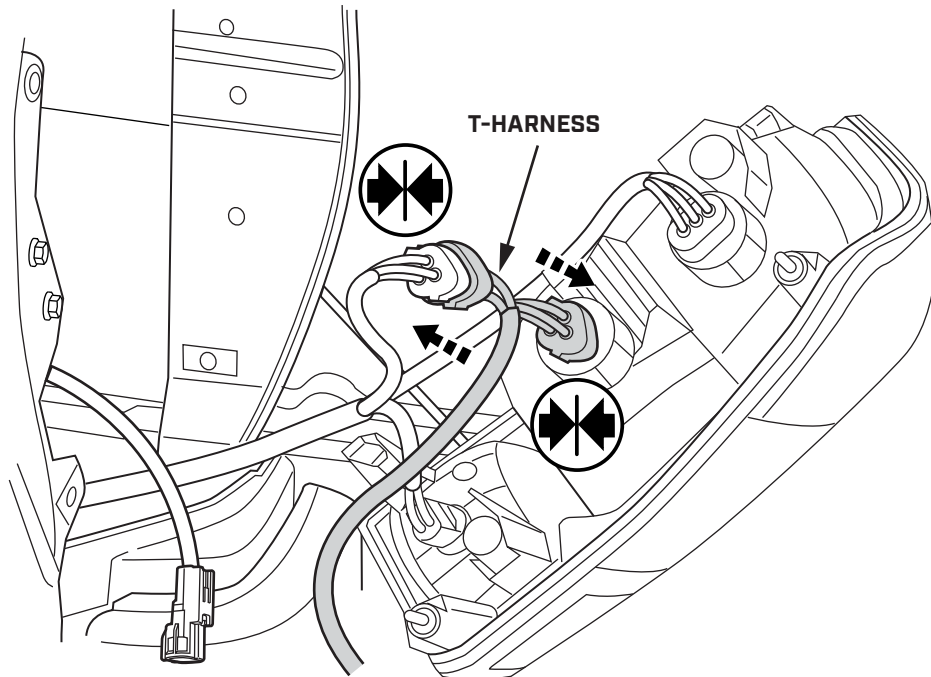
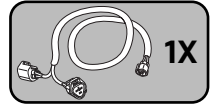

STEP 29

CONNECT THE T-HARNESS TO THE EXTENSION HARNESS.

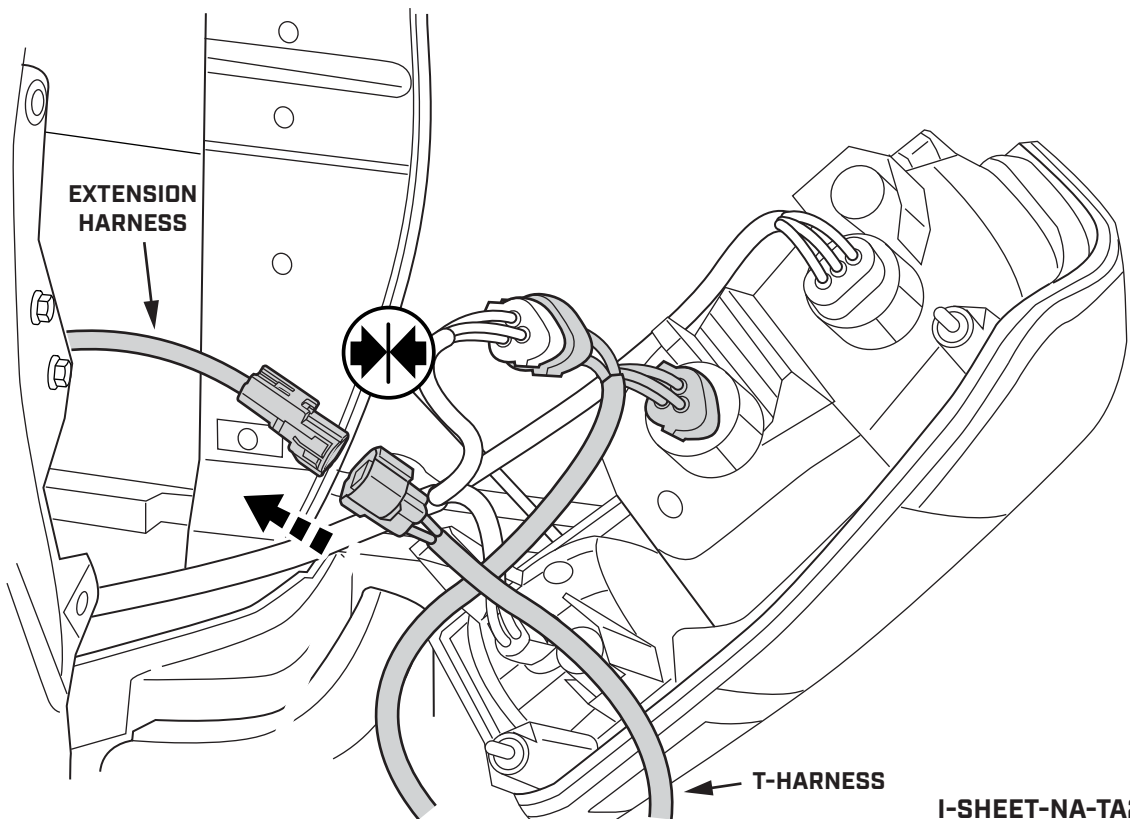

I-SHEET-NA-TA2

STEP 30

BUNDLE EXTRA T-HARNESS LENGTH IN THE TAILLIGHT CAVITY AND SECURE WITH CABLE TIES.

REINSTALL THE TAILLIGHT ASSEMBLY.

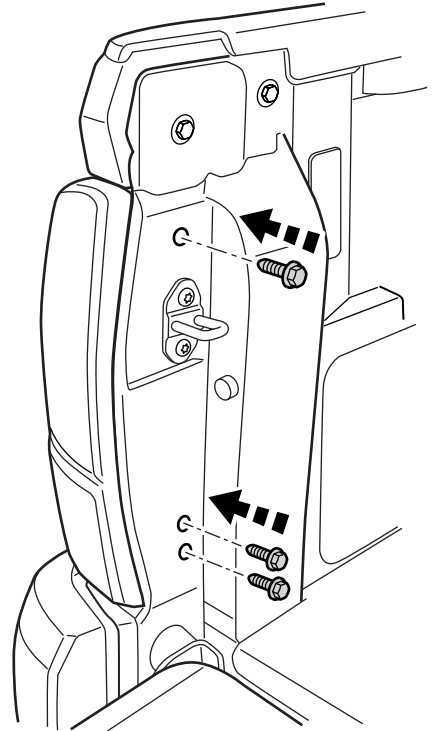
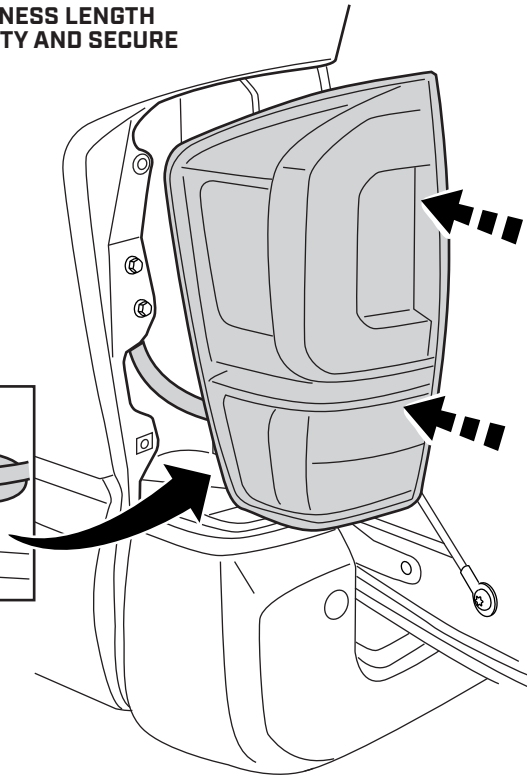
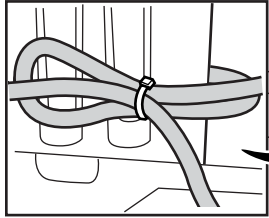

STEP 31

USE 4 PEOPLE TO LIFT THE ASSEMBLED SMARTCAP ONTO THE TRUCK BED.

TO AVOID DAMAGE TO THE D-RUBBER, DO NOT SLIDE THE SMARTCAP INTO PLACE.

4 PERSON JOB

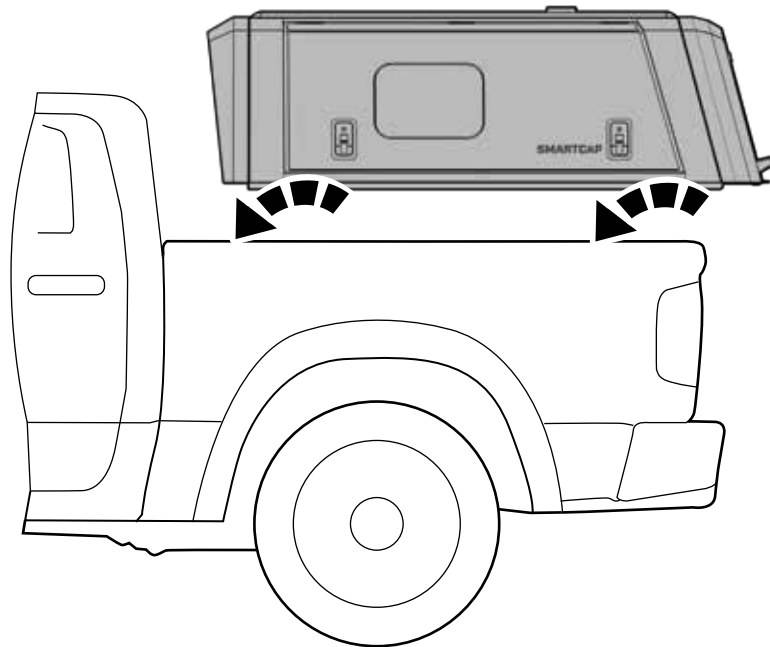

I-SHEET-NA-TA2

STEP 32

CHECK THAT THE SMARTCAP IS PROPERLY POSITIONED AND CENTERED ON THE TRUCK BED.

IT'S IMPORTANT THAT THE SMARTCAP IS NOT PUSHED TOO FAR FORWARD, LEAVING A GAP BETWEEN THE SMARTCAP AND THE CAB.

4 PERSON JOB

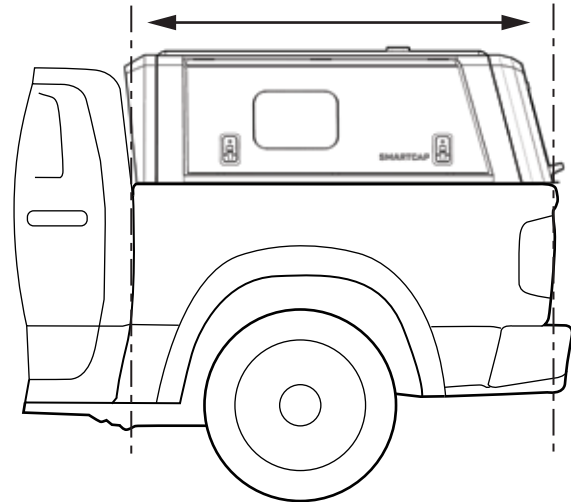
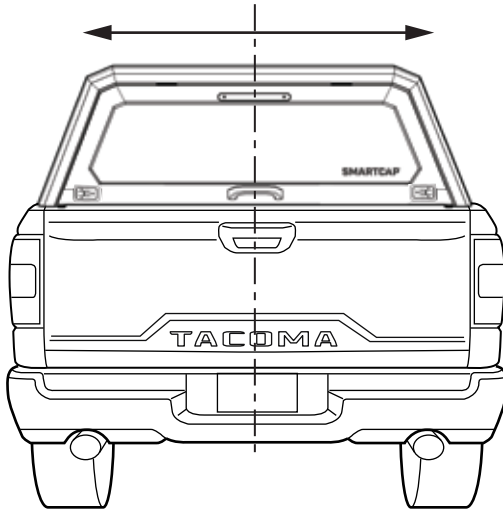
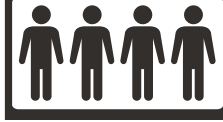

STEP 33

WALK AROUND THE TRUCK BED TO MAKE SURE THE D-RUBBER FITMENT IS CORRECT AND THAT THE RUBBER LIP IS PROPERLY TUCKED UNDERNEATH THE CAP.

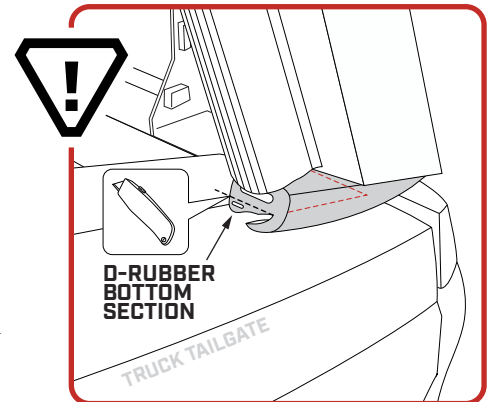
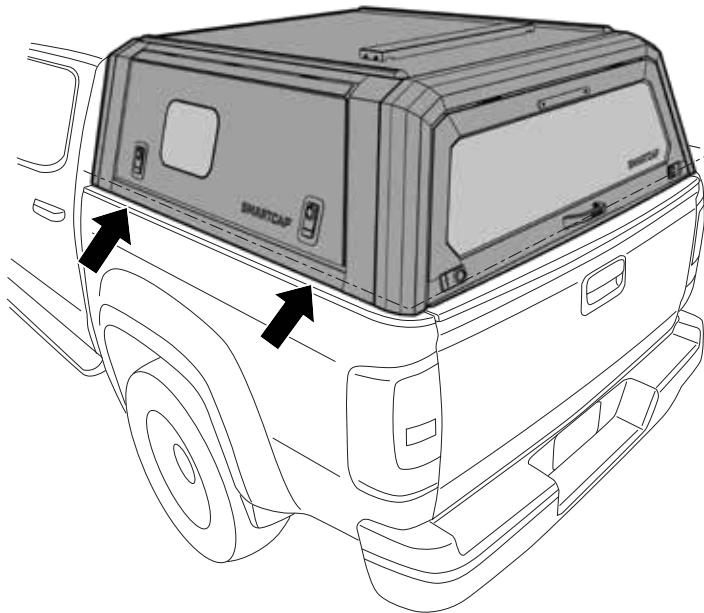

***DO NOT TRIM THE LIP**

USING A SHARP KNIFE, CUT AWAY THE BOTTOM SECTION OF THE D-RUBBER TO PROVIDE CLEARANCE FOR THE TAILGATE. MEASURE WHERE THE CAP OVERLAPS THE TAILGATE TO DETERMINE HOW FAR THE D-RUBBER BOTTOM SHOULD BE TRIMMED.

**YOU MAY NOTICE THAT THE SEAL ON THE SLIDING PORTAL WINDOW MIGHT APPEAR WRINKLED. THIS IS DUE TO THE ANTI-SLIP COATING AND IS NOT A CAUSE FOR CONCERN.*

I-SHEET-NA-TA2

STEP 34



WITH THE EXCEPTION OF THE REAR CORNERS, PLACE THE THIN RUBBER PADS NEXT TO GUSSETS ON BOTH SIDES OF THE CAP.

3 PADS PER SIDE

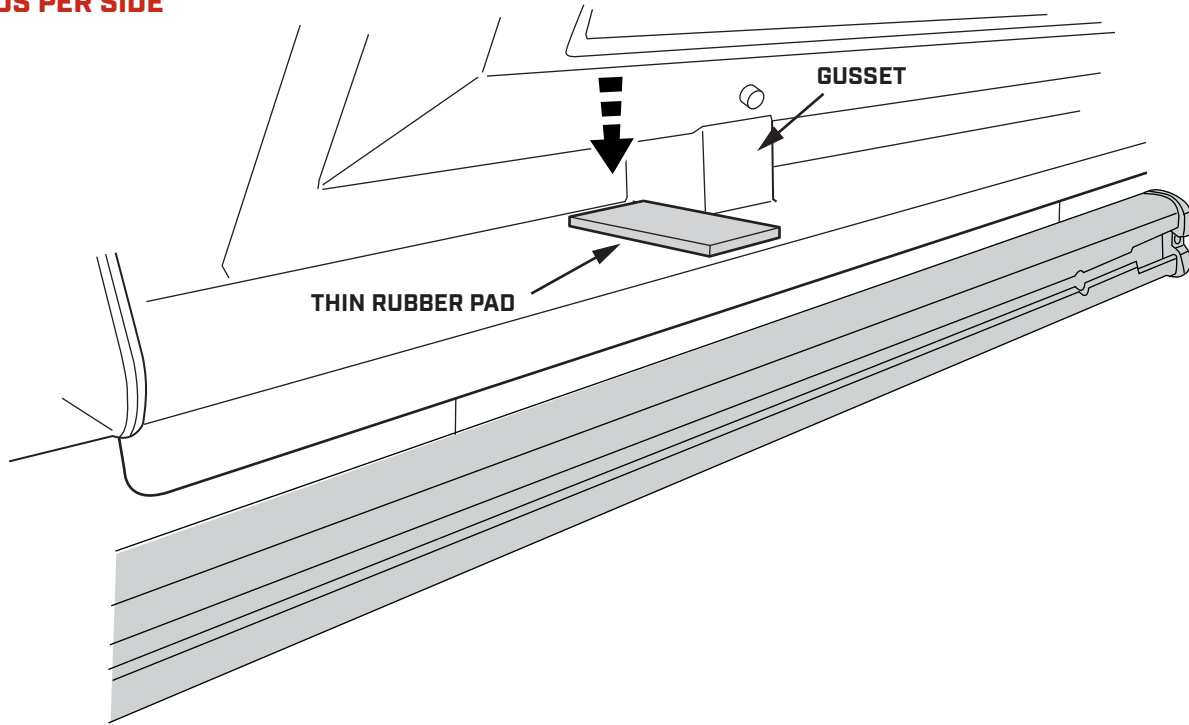

STEP 35



DISASSEMBLE MOUNTING CLAMPS.

INSTALL LOWER CLAMP ARMS INTO RAIL INSIDE TRUCK BED AND SET THEM IN FRONT OF EVERY THIN RUBBER PAD.

3 CLAMPS PER SIDE

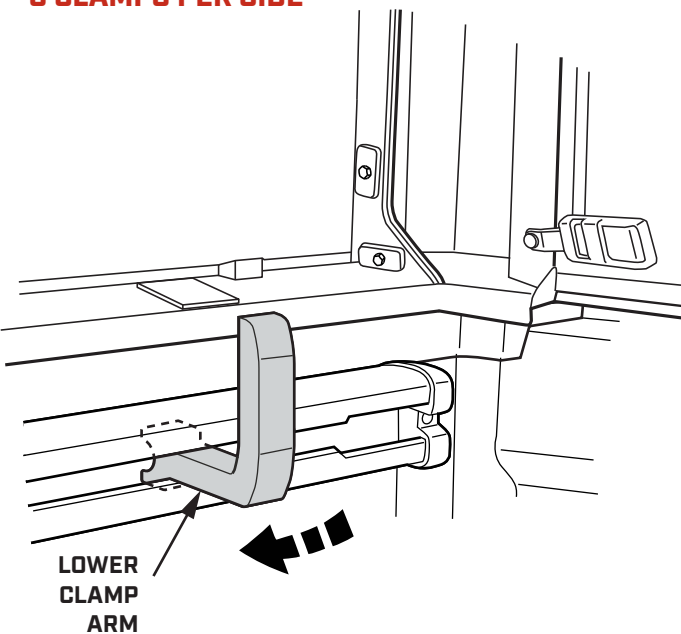

STEP 36

REASSEMBLE UPPER AND LOWER CLAMP ARMS.

HAND TIGHTEN ALL MOUNTING CLAMPS ON TOP OF THIN RUBBER PADS.

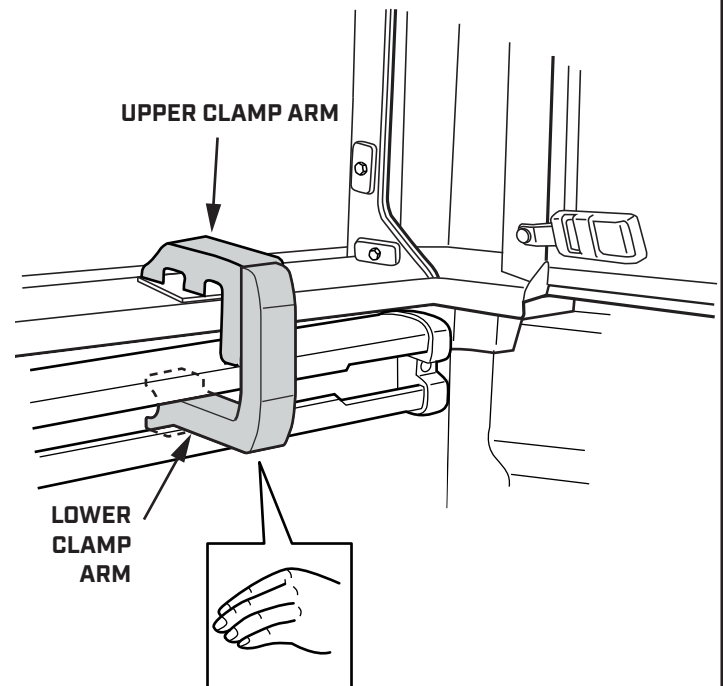

I-SHEET-NA-TA2

STEP 37

TIGHTEN MOUNTING CLAMPS USING TORQUE WRENCH AND 13MM SOCKET TO 4.4 FT. LBS. [6 NEWTON METERS]

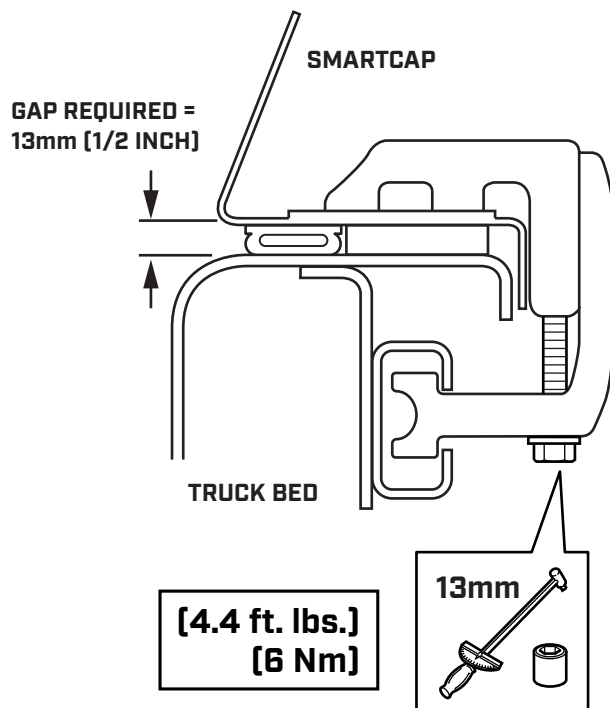

STEP 38

CONNECT THE EXTENSION HARNESS TO THE SMARTCAP'S THIRD BRAKE LIGHT HARNESS.

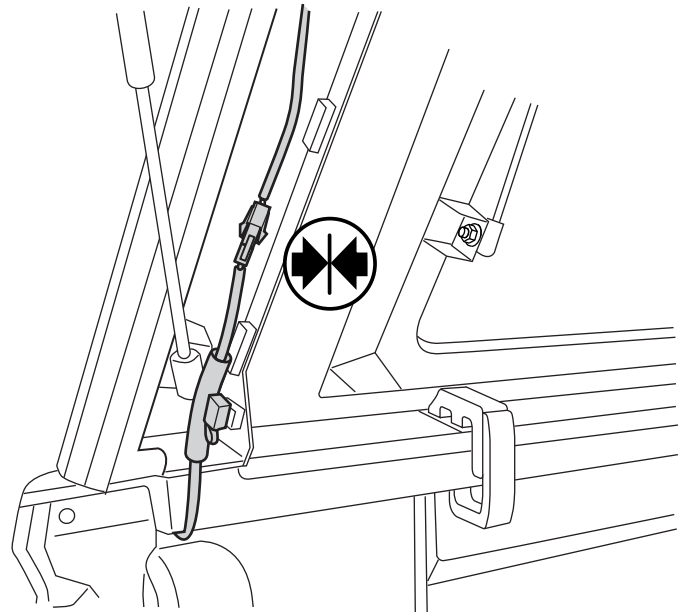

STEP 39



TEST YOUR BRAKE LIGHTS & TURN SIGNALS

- ▼ START THE TRUCK. SOME MODELS MAY TAKE UP TO 30 SECONDS FOR THE VEHICLE TO DETECT THE NEW CONNECTION.
- ▼ CHECK THE BRAKE LIGHTS AND TURN SIGNALS TO BE SURE THEY ARE FUNCTIONING PROPERLY.
- ▼ ONCE YOU HAVE CONFIRMED THAT THE LIGHTS ARE WORKING CORRECTLY, SECURE THE HARNESS WITH CABLE TIES.
- ▼ BE SURE NOT TO INTERFERE WITH ANY MOVING PARTS ON THE VEHICLE.



THANKS FOR YOUR PURCHASE.
PLEASE LET US KNOW IF YOU HAVE ANY QUESTIONS.

SMARTCAP.COM - SUPPORT.NA@SMARTCAP.COM - NORTH AMERICA



I-SHEET-NA-TA2

STEP 17

INSTALL HARDWARE ALONG REAR FLANGE WITH BOLT ON INSIDE.

START WITH ASSEMBLING FASTENER BLOCKS 1-5.

ADJUST LEFT AND RIGHT PANELS TO ALIGN FASTENER BLOCKS 6-15 FOR ASSEMBLY.

HAND TIGHTEN IN THE SEQUENCE SHOWN.

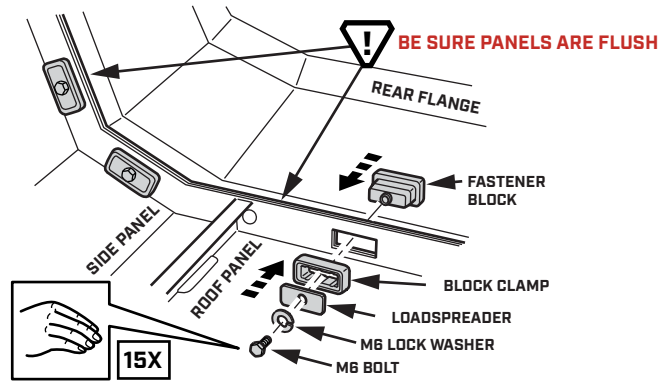

STEP 18

TIGHTEN ALL HARDWARE WITH TORQUE WRENCH AND 10MM SOCKET TO 3.7 FT. LBS. [5 NEWTON METERS]

