

**SMARTCAP®**

# **INSTRUCTION GUIDE**

## **FORD SUPER DUTY EDITION**

### **2017-CURRENT (4th Generation)**

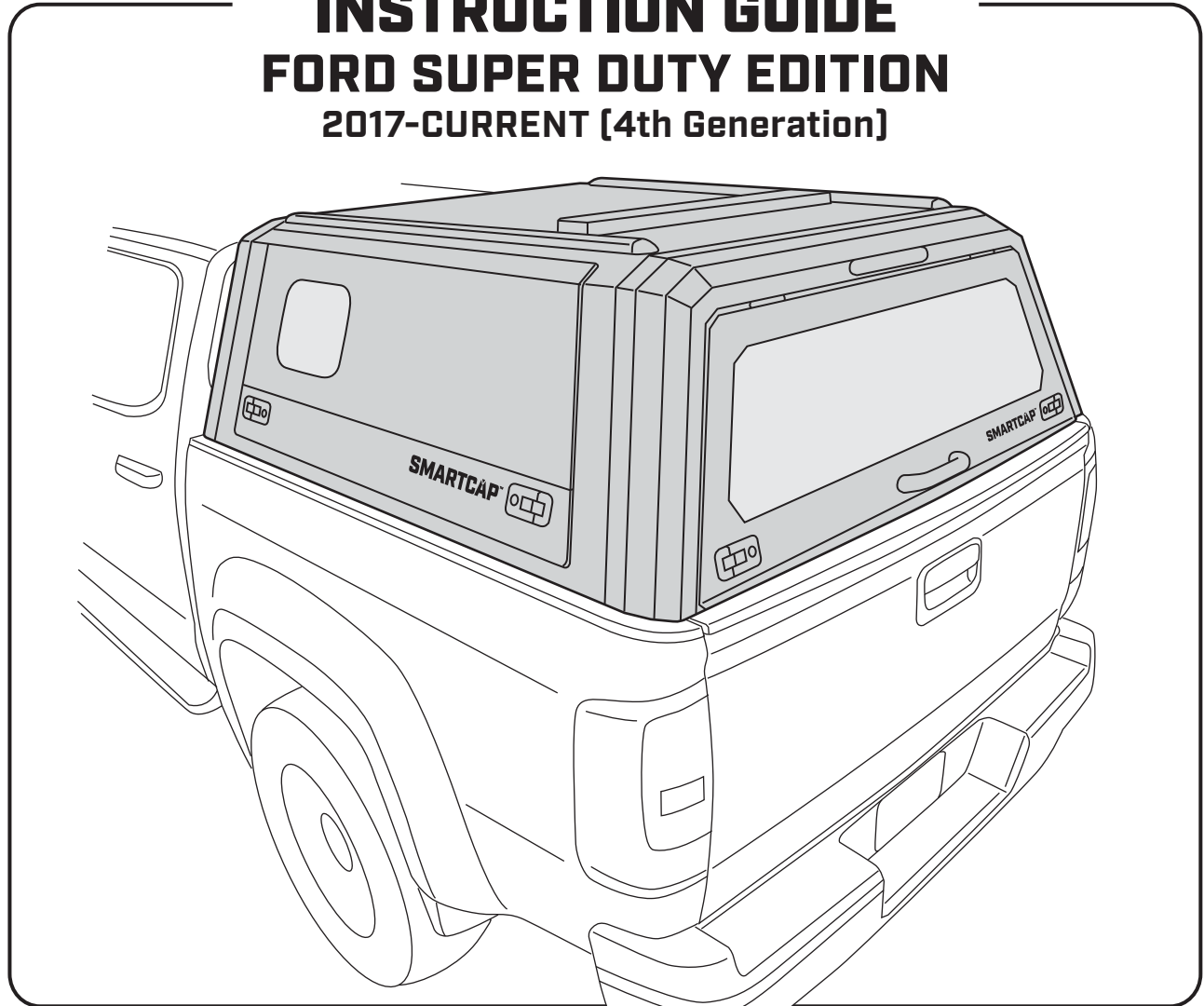

- ▼ **PREPARE A CLEAN WORK AREA.**
- ▼ **WE RECOMMEND A MINIMUM OF 2 PEOPLE FOR ASSEMBLY AND 4 PEOPLE FOR INSTALLATION.**
- ▼ **ENSURE THE REQUIRED TOOLS ARE PRESENT AND ALL HARDWARE CONTENTS ARE ACCOUNTED FOR.**
- ▼ **NEVER USE ACETONE OR THINNERS ON PAINTED PARTS.**
- ▼ **READ THROUGH THE ENTIRE INSTRUCTION GUIDE BEFORE STARTING THIS PROCEDURE AND FOLLOW THE STEPS CAREFULLY TO AVOID ANY DAMAGE TO THE COMPONENTS OR THE VEHICLE.**

**SMARTCAP.COM**

SUPPORT.NA@SMARTCAP.COM - NORTH AMERICA

SUPPORT.SA@SMARTCAP.COM - REST OF WORLD



I-SHEET-NA-S3

## TOOLS REQUIRED



## IMPORTANT

- ▼ USE ONLY THE TOOLS RECOMMENDED ABOVE.
- ▼ USE ONLY THE HARDWARE PROVIDED IN THIS KIT.
- ▼ ASSISTANCE WILL BE NEEDED FOR THIS INSTALLATION. FOUR PEOPLE ARE RECOMMENDED TO LIFT THE SMARTCAP ONTO THE VEHICLE.
- ▼ AVOID PINCHING OR CRUSHING HANDS AND FINGERS.
- ▼ INSPECT ALL KIT COMPONENTS FOR DAMAGE BEFORE ASSEMBLY.
- ▼ NEVER USE ACETONE OR THINNERS ON PAINTED PARTS.

## COMPONENTS

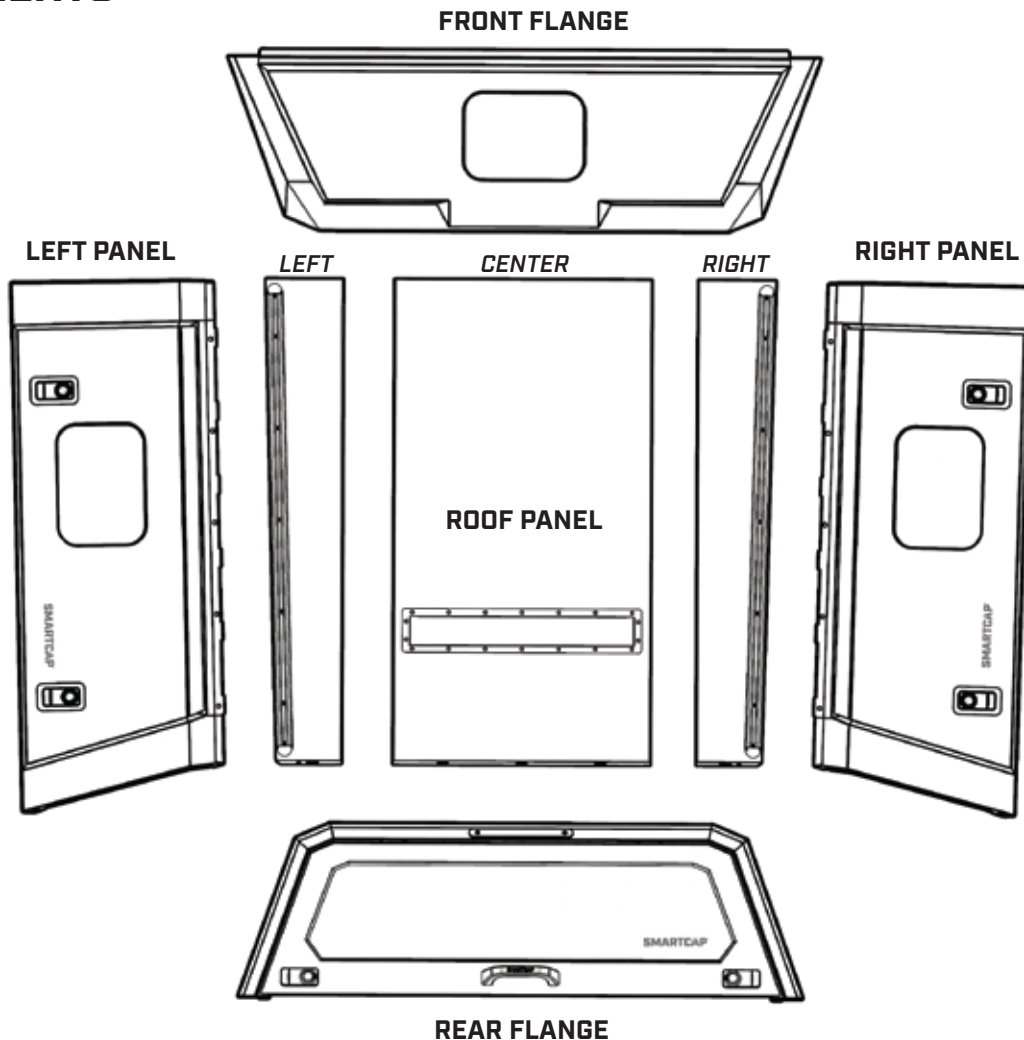

I-SHEET-NA-S3

# ASSEMBLY HARDWARE

## FITMENT KIT

**M6 BOLT**

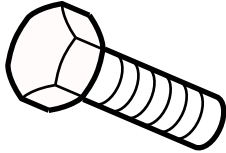

**42X**

**FASTENER  
BLOCK CLAMP**

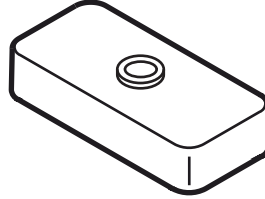

**42X**

**M6 LOCK  
WASHER**

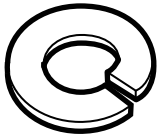

**42X**

**FASTENER  
BLOCK**

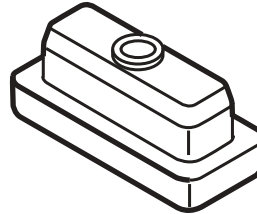

**42X**

**D - RUBBER**



**1X**

**SPARE PARTS**

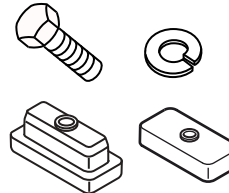

**2X**

**M6  
FENDER WASHER**

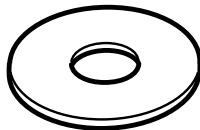

**12X**

**M6  
LOCK NUT**

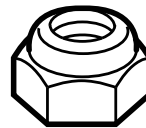

**12X**

# STEP 1



## IMPORTANT

▼ BE SURE TO REMOVE ALL SEVEN PANELS FROM THEIR PACKAGING AND INSPECT THE PAINTED SURFACES PRIOR TO ASSEMBLY, AS SMARTCAP WILL NOT ACCEPT WARRANTY CLAIMS AFTER ASSEMBLY IS COMPLETED. IF MANUFACTURING IMPERFECTIONS OR SHIPPING DAMAGES ARE FOUND, DO NOT CONTINUE WITH THE ASSEMBLY PROCESS AND CONTACT [SUPPORT.NA@SMARTCAP.COM](mailto:SUPPORT.NA@SMARTCAP.COM)

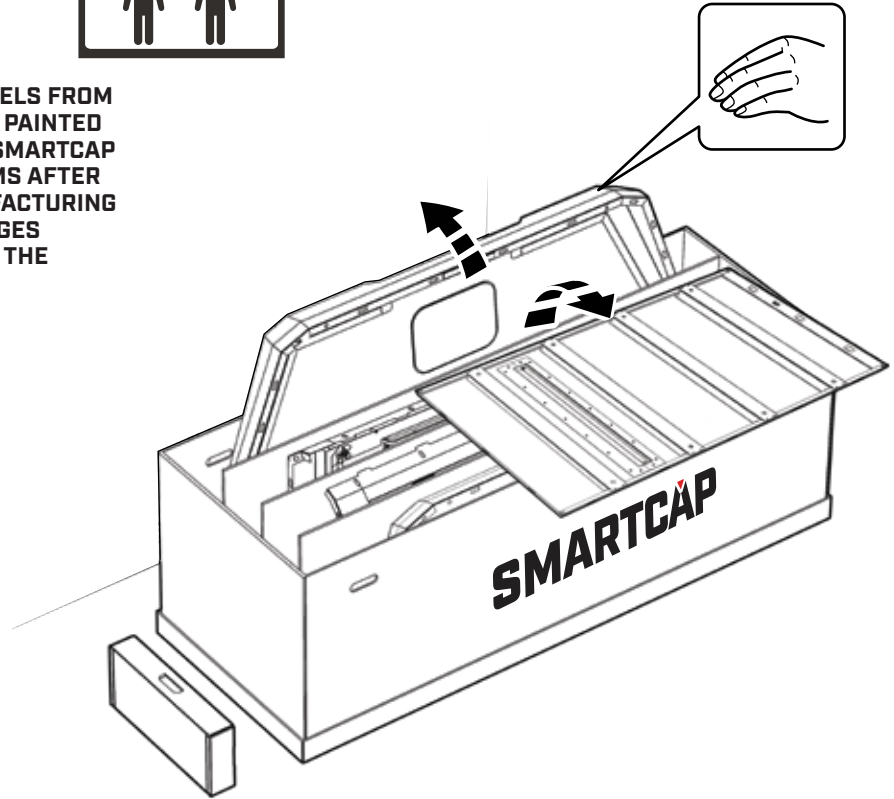

# STEP 2

REMOVE THE FOUR CORNER STIFFENERS AND ONE OF THE CARDBOARD DIVIDERS TO BE USED AS A PROTECTIVE SURFACE DURING ASSEMBLY.

UNFOLD THE CARDBOARD DIVIDER AND PLACE IT WHERE YOU PLAN TO ASSEMBLE YOUR CAP.

PLACE THE FOUR CORNER STIFFENERS AS SHOWN BELOW.

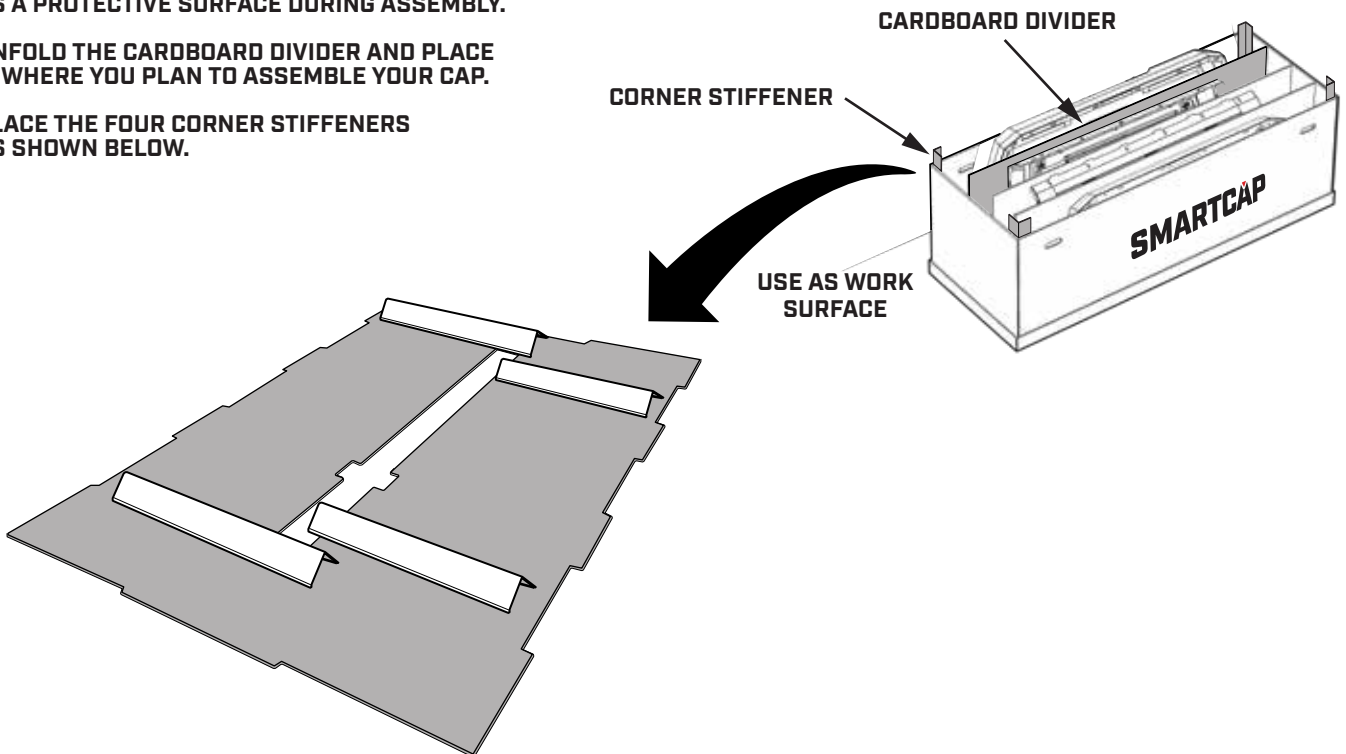

# STEP 3

PLACE THE ROOF PANELS ON TOP OF THE CORNER STIFFENERS, WITH THE BOTTOM OF THE ROOF PANELS FACING UP.

ALIGN THE PANELS SO THAT THE PROFILE OF THE FRONT AND REAR EDGES MATCH.

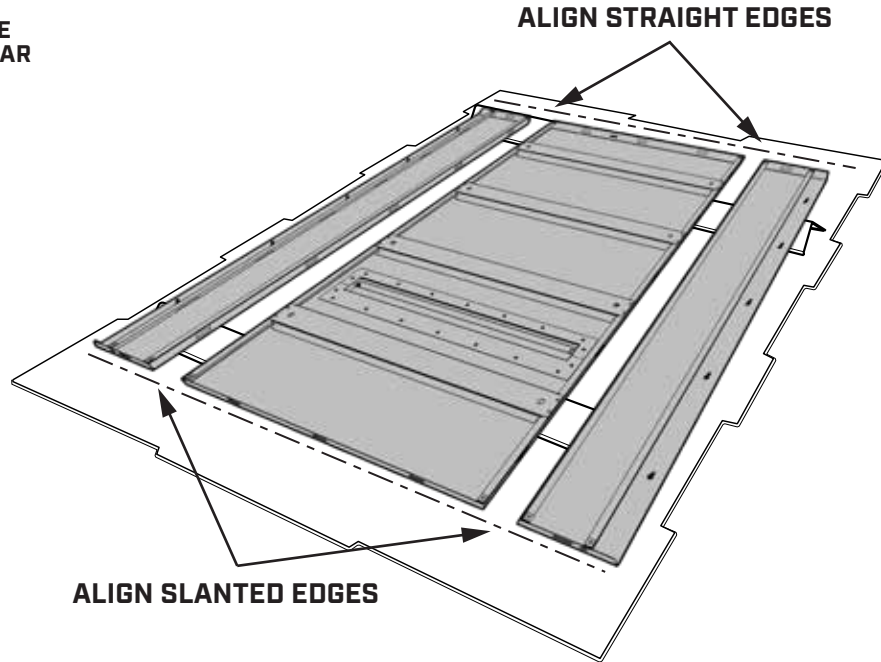

# STEP 4

ASSEMBLE THE FASTENER BLOCKS TO THE ROOF PANELS USING A TORQUE WRENCH AND 10MM SOCKET TO 3.7 FT. LBS [5 NEWTON METERS].



**MAKE SURE ROOF PANELS ARE LEVEL**

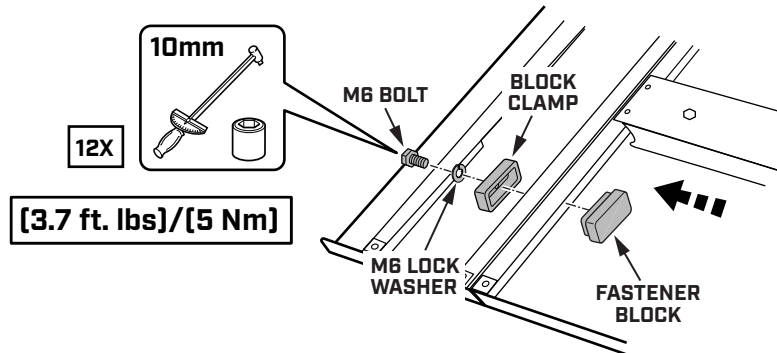
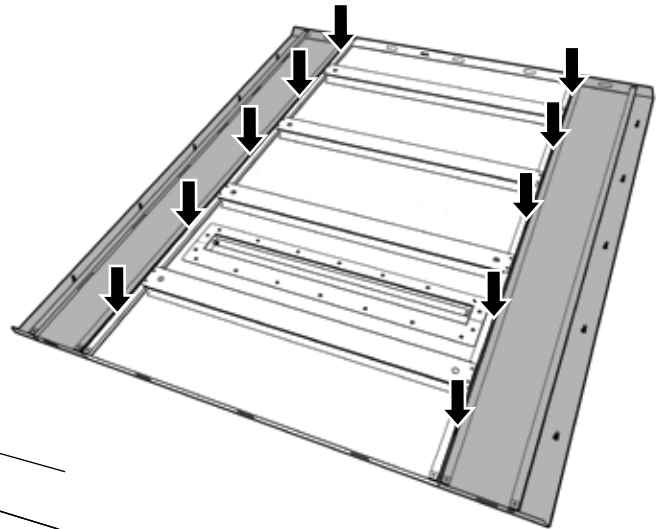
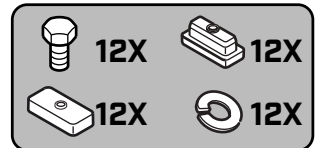

I-SHEET-NA-S3

# STEP 5

USE A 10MM COMBINATION WRENCH TO REMOVE THE LOCK NUTS AND FENDER WASHERS FROM THE ROOF BOLTS AND SAVE FOR REUSE.



**AIR VENT INDICATES REAR**

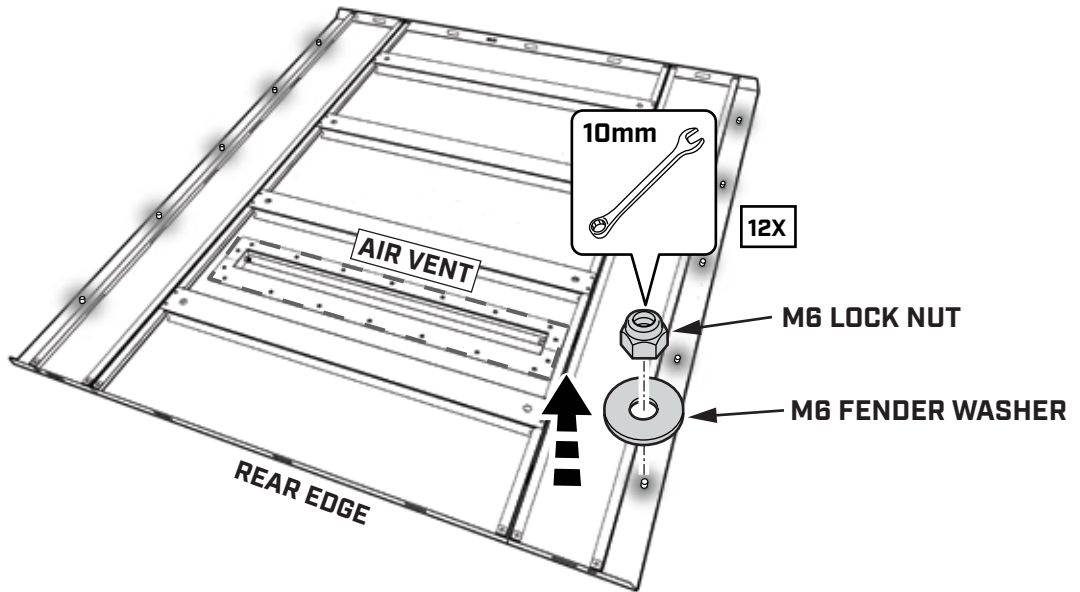

# STEP 6

RETRIEVE THE FASTENER BLOCKS FROM THE FITMENT KIT AND PLACE 15 ON EACH SIDE OF THE ROOF PANEL.

TAKE APART THE FASTENER BLOCKS SO THEY ARE READY TO USE DURING ASSEMBLY.

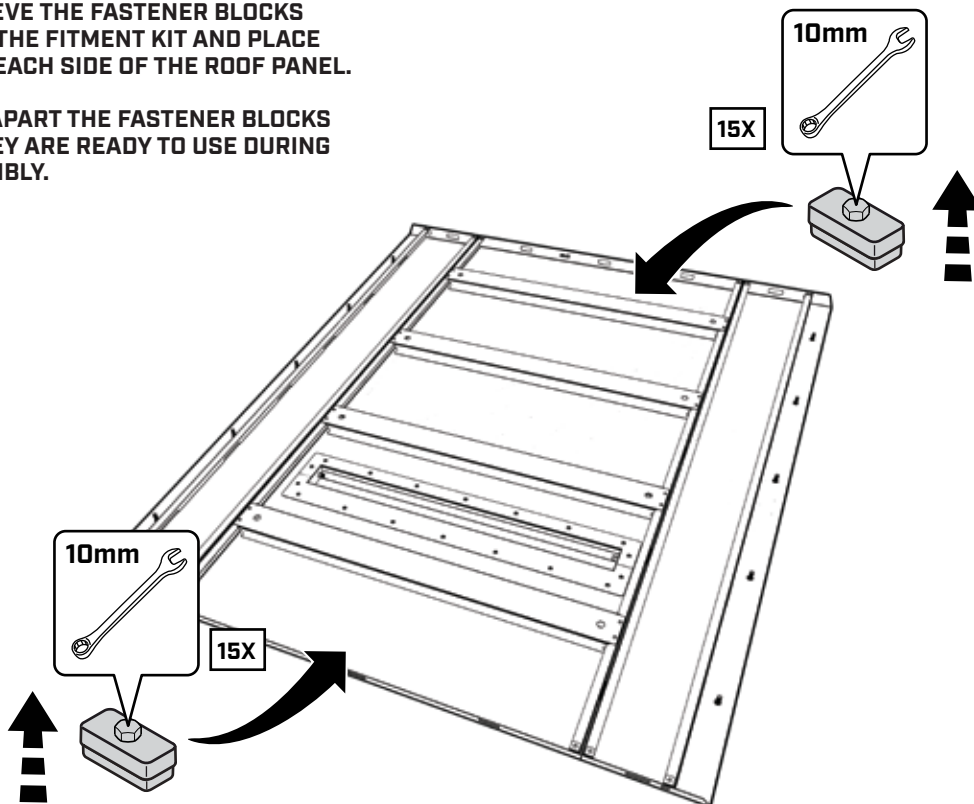
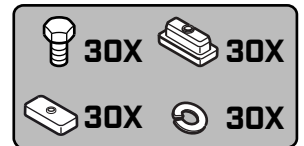

# STEP 7

LOCATE THE RIGHT PANEL IN THE SMARTCAP PACKAGE AND BRING IT TO YOUR WORK AREA.



SLANTED EDGE INDICATES REAR

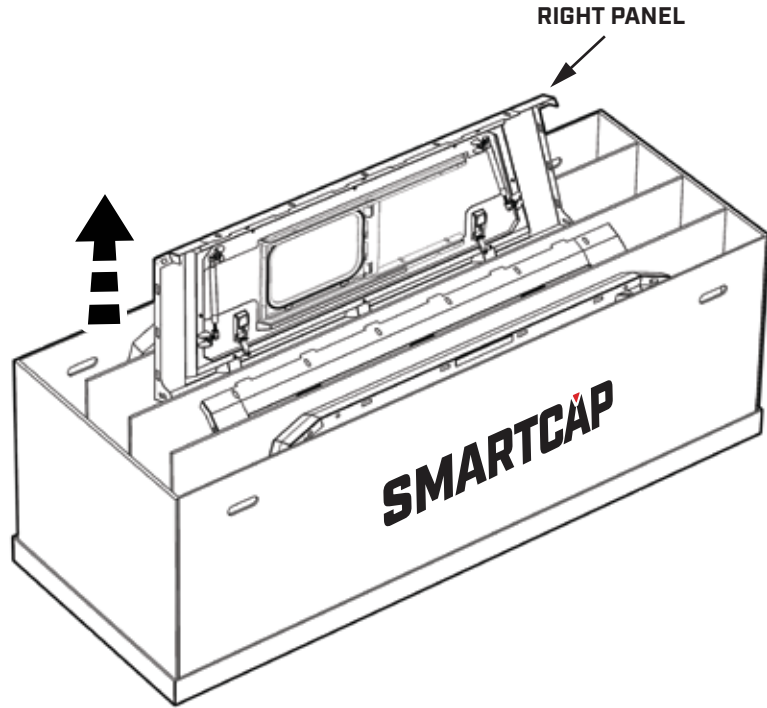

# STEP 8

INSERT PANEL TABS INTO THE NARROW SLOTS JUST ABOVE FOAM PADDING ON ROOF PANEL.

TAP FIRMLY WITH PALM OF HAND UNTIL THERE IS A 2-3MM GAP.

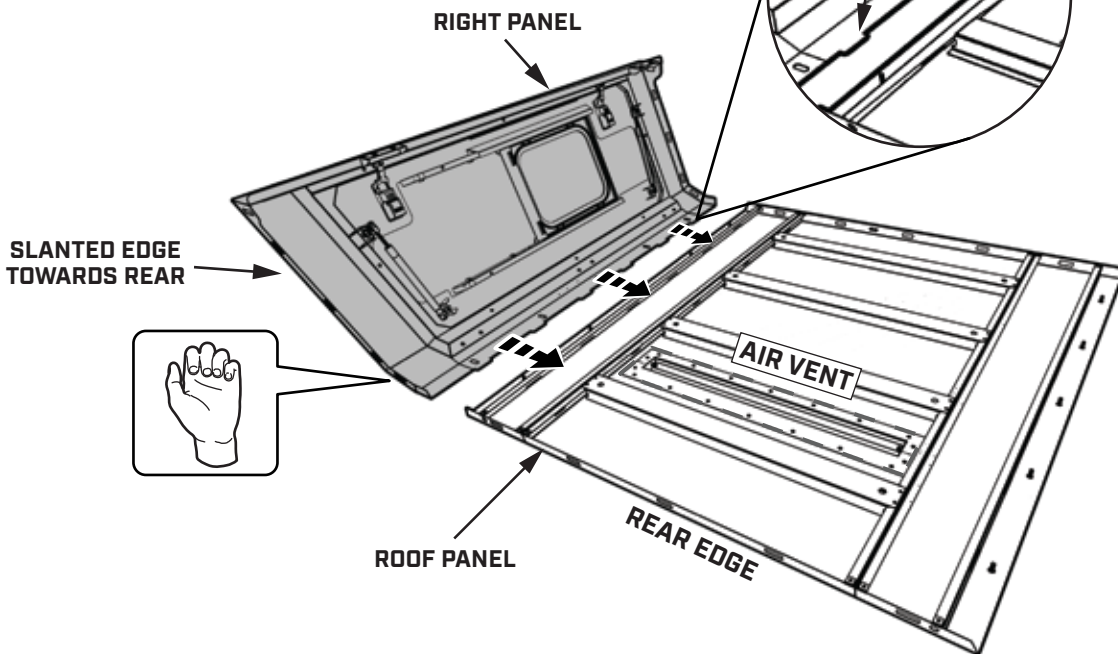
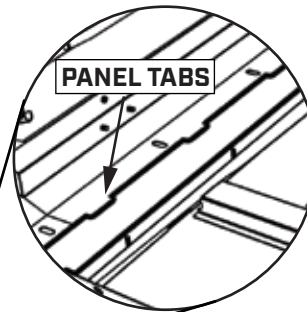

# STEP 9

HAND TIGHTEN M6 LOCK NUT WITH M6 FENDER WASHER TO ALL BOLTS.



**SUPPORT RIGHT PANEL UNTIL ASSEMBLED TO FRONT FLANGE**

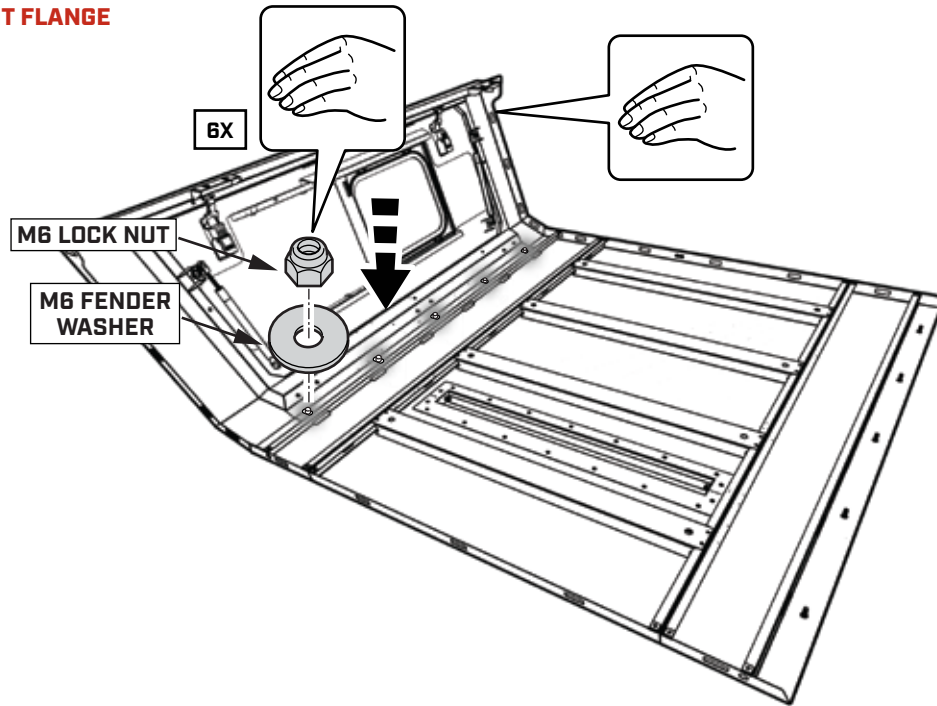

# STEP 10

LOCATE THE FRONT FLANGE IN THE SMARTCAP PACKAGE AND BRING IT TO YOUR WORK AREA.

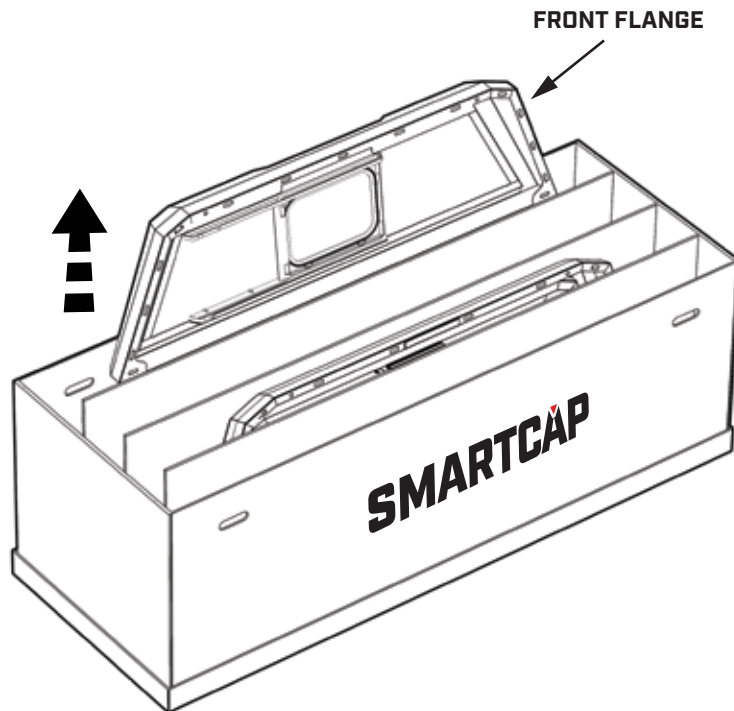

# STEP 11

PLACE FRONT FLANGE AS SHOWN BELOW.

HAND TIGHTEN TWO FASTENER BLOCKS AT THE INDICATED LOCATIONS TO SUPPORT THE RIGHT PANEL AND FRONT FLANGE.

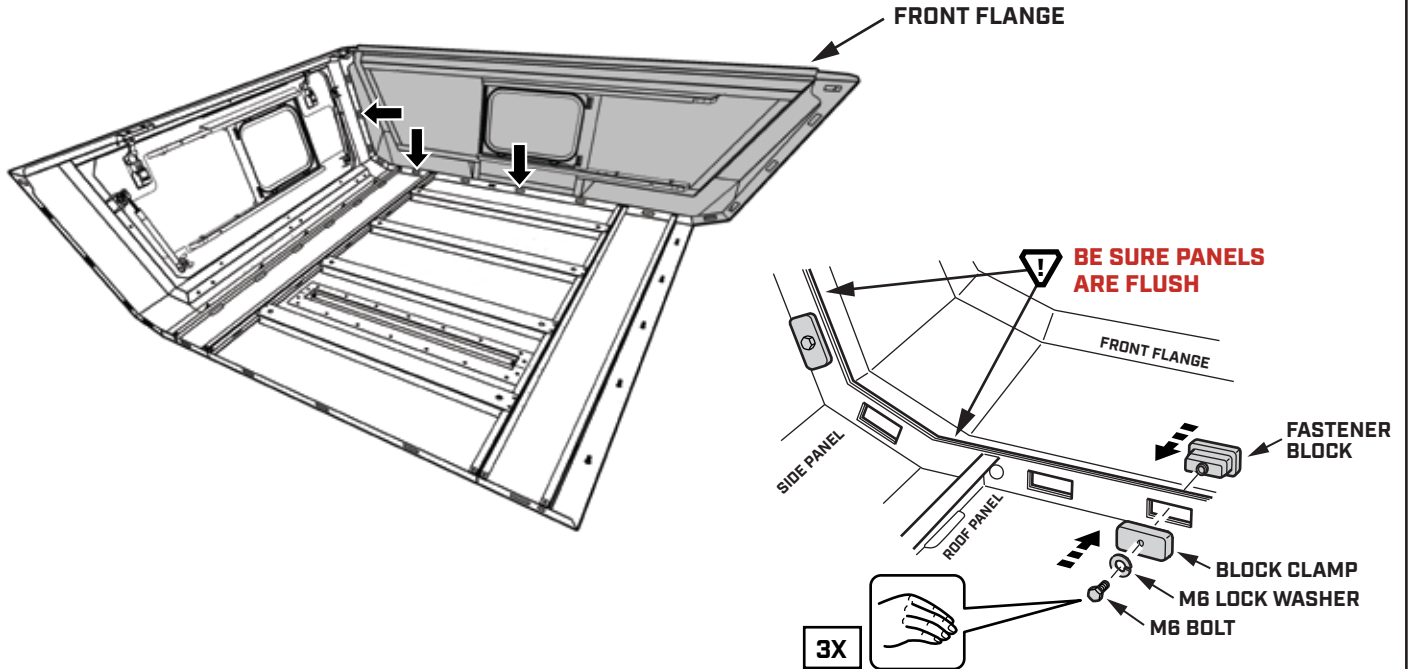

# STEP 12

LOCATE THE LEFT PANEL IN THE SMARTCAP PACKAGE AND BRING IT TO YOUR WORK AREA.



 **SLANTED EDGE INDICATES REAR**

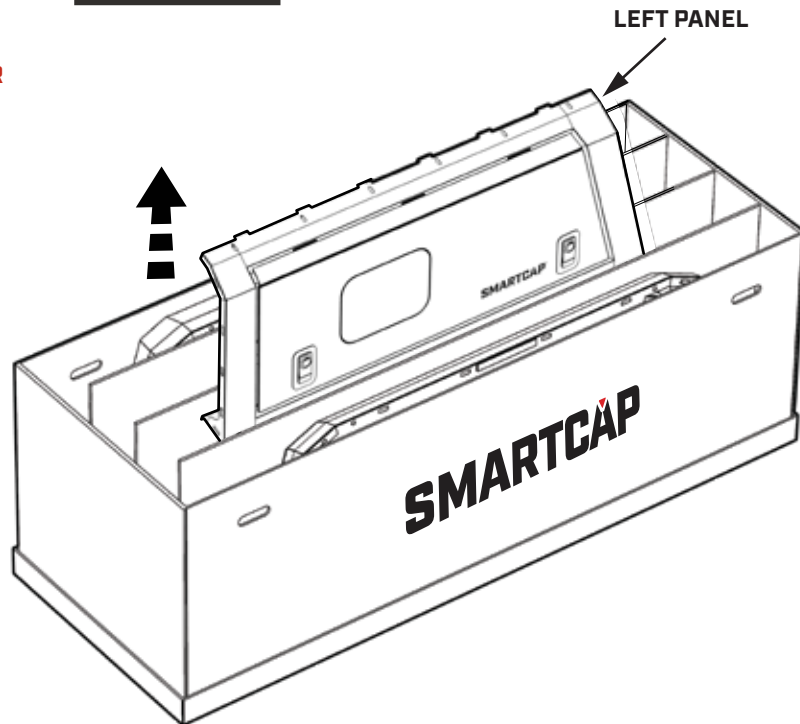

# STEP 13

INSERT PANEL TABS INTO THE NARROW SLOTS JUST ABOVE FOAM PADDING ON ROOF PANEL.

TAP FIRMLY WITH PALM OF HAND UNTIL THERE IS A 2-3MM GAP.

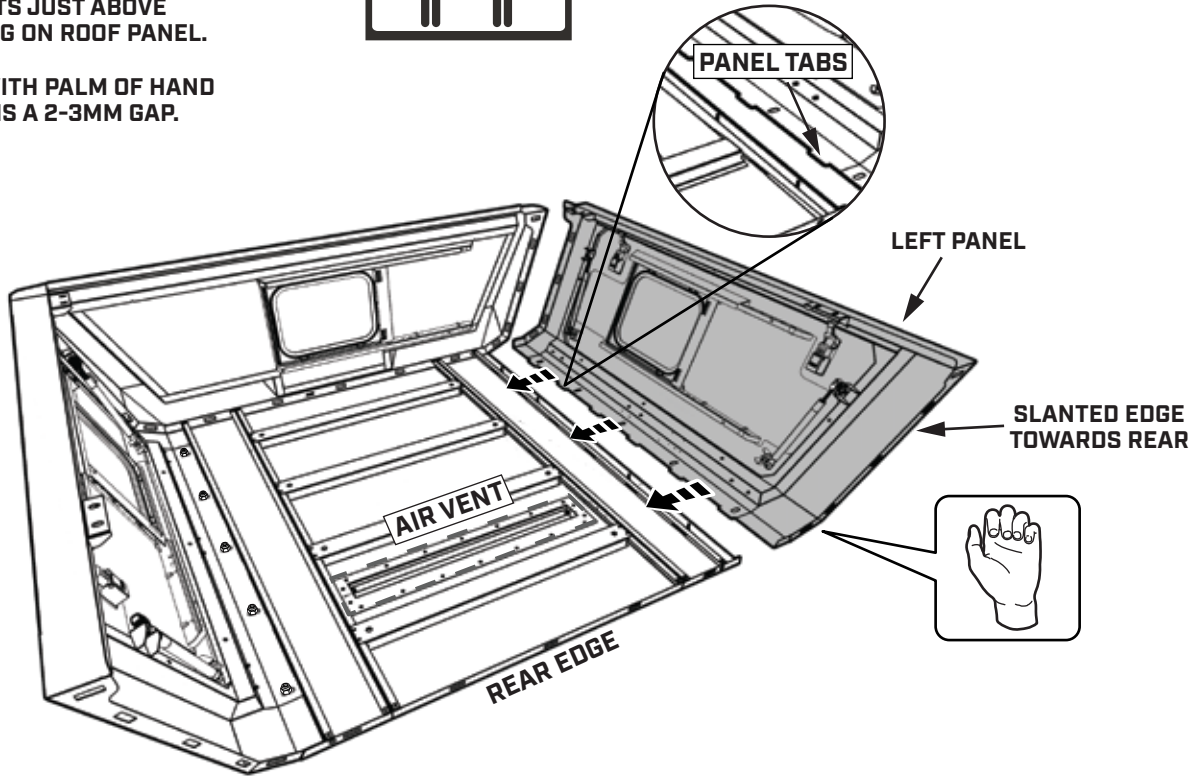

# STEP 14

HAND TIGHTEN M6 LOCK NUT WITH M6 FENDER WASHER TO ALL BOLTS.



**! SUPPORT LEFT PANEL UNTIL ASSEMBLED TO FRONT FLANGE**

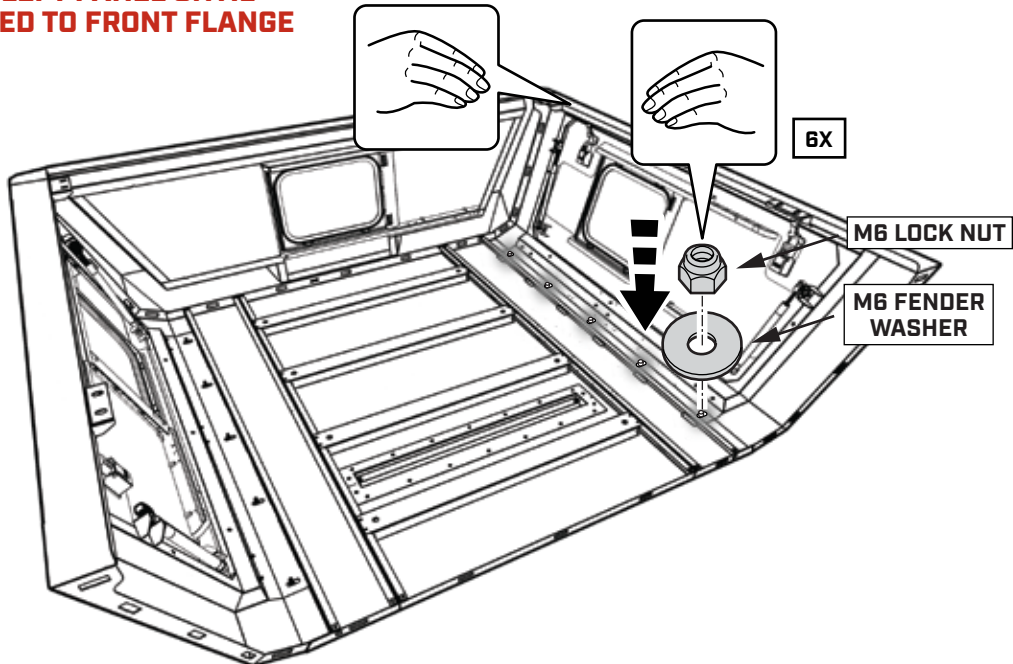

# STEP 15

INSTALL HARDWARE ALONG FRONT FLANGE WITH BOLT ON INSIDE.

START AT CENTER OF THE FRONT FLANGE AND WORK YOUR WAY OUTWARDS.

ADJUST LEFT AND RIGHT PANELS TO ALIGN THE FASTENER BLOCK HOLES.

HAND TIGHTEN ONLY.

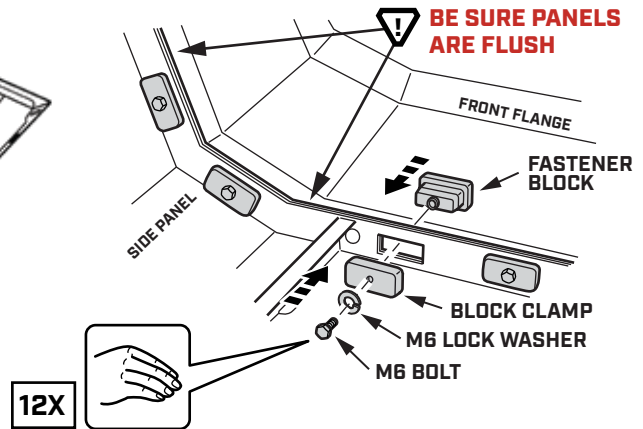
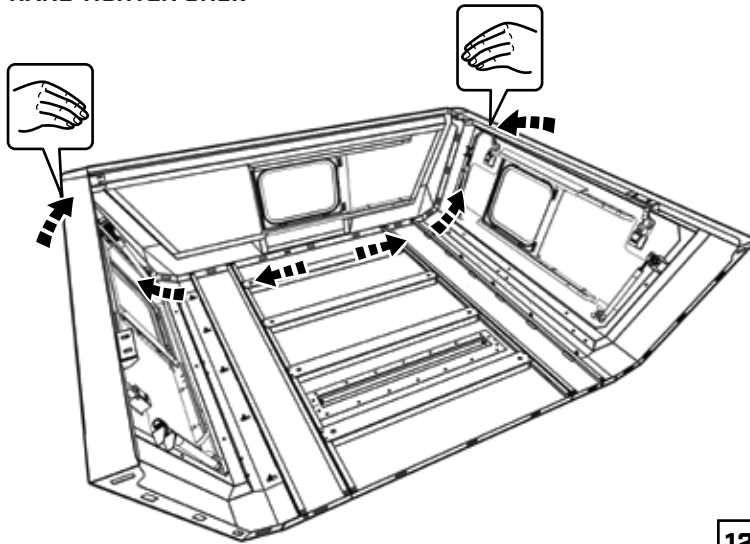

# STEP 16

LOCATE THE REAR FLANGE IN THE SMARTCAP PACKAGE AND BRING IT TO YOUR WORK AREA.

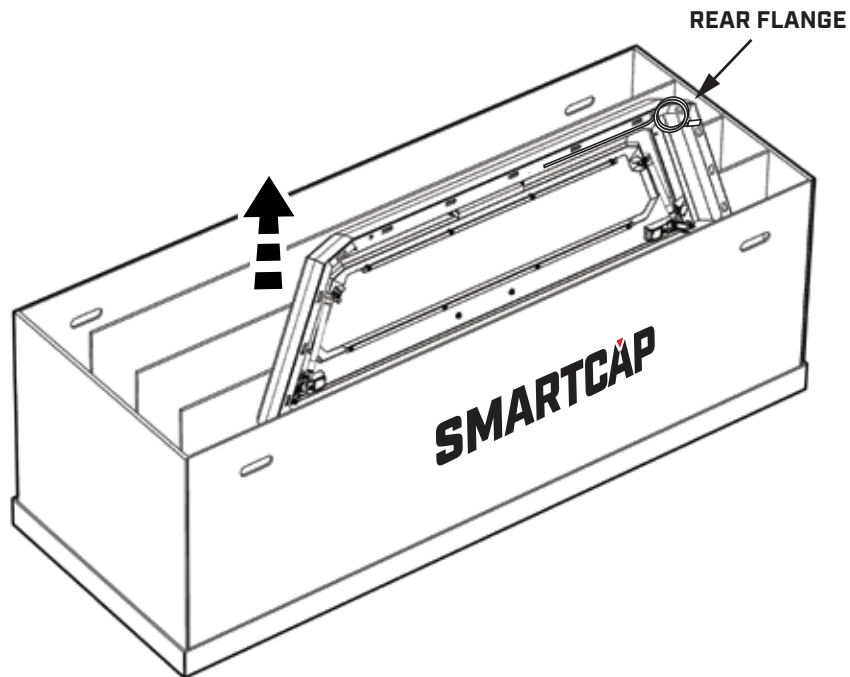

# STEP 17

PLACE REAR FLANGE AS SHOWN BELOW.

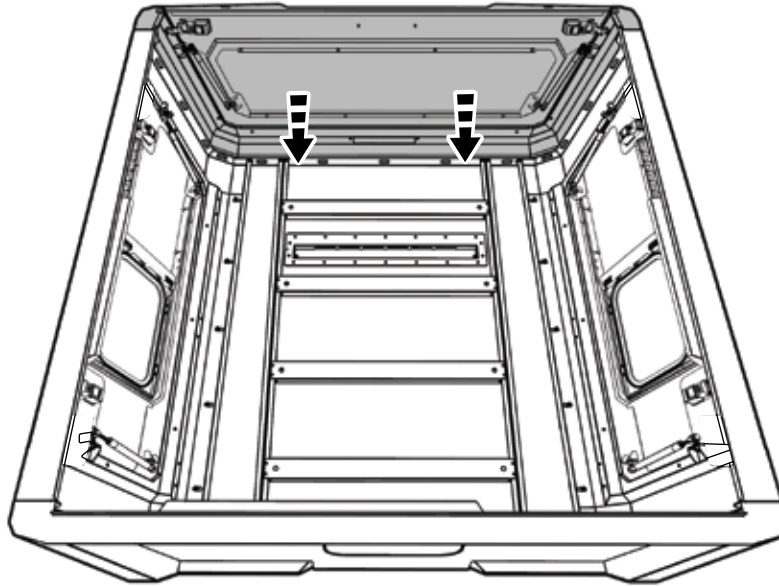

# STEP 18

INSTALL HARDWARE ALONG REAR FLANGE WITH BOLT ON INSIDE.

START AT CENTER OF THE REAR FLANGE AND WORK YOUR WAY OUTWARDS.

ADJUST LEFT AND RIGHT PANELS TO ALIGN THE FASTENER BLOCK HOLES.

HAND TIGHTEN ONLY.

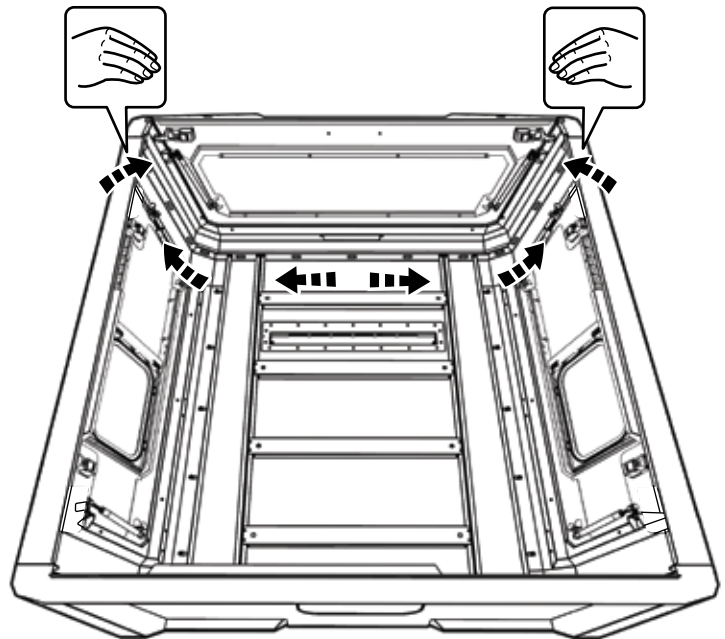
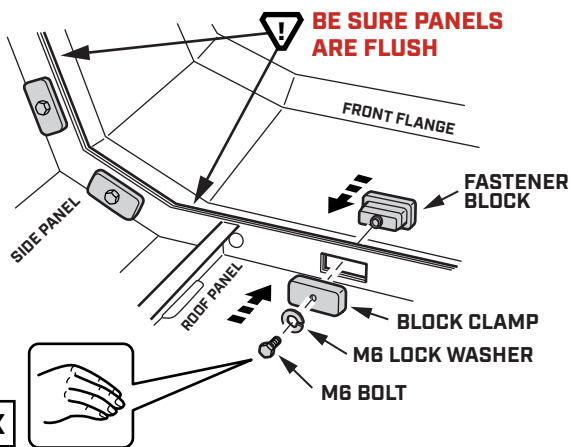

# STEP 19

TIGHTEN ALL HARDWARE WITH TORQUE WRENCH AND 10MM SOCKET TO 3.7 FT. LBS. (5 NEWTON METERS)

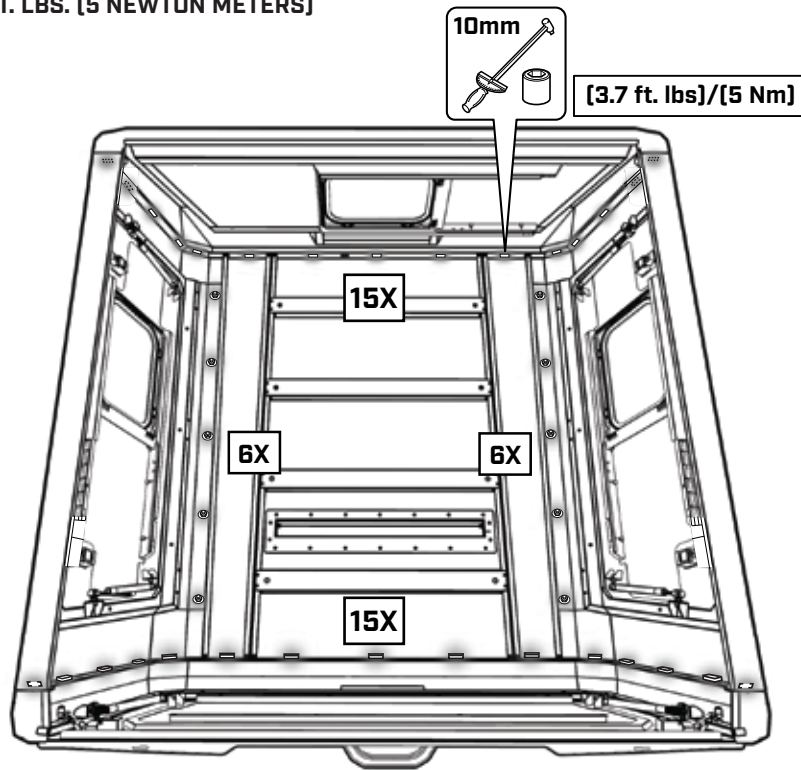

# STEP 20

ENSURE THE ENTIRE BOTTOM EDGE OF THE SMARTCAP IS CLEAN.

LOCATE BOTH RETENTION TABS ON THE REAR FLANGE AND BEND EACH TO A 45-DEGREE ANGLE FOR D-RUBBER FITMENT.

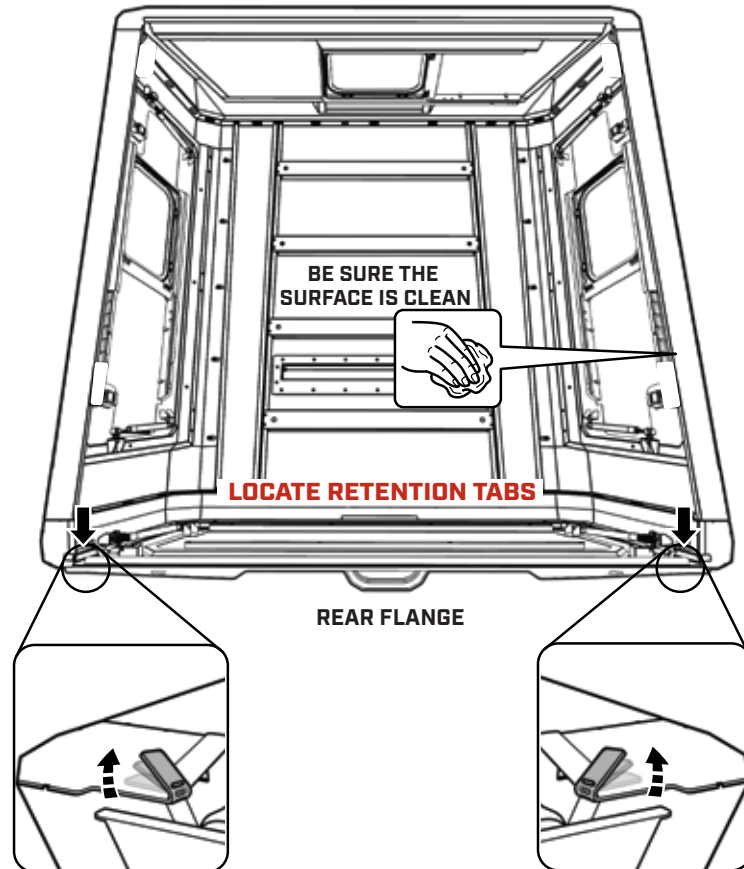

# STEP 21



TRIM THE D-RUBBER WITH A CLEAN, STRAIGHT CUT.

APPLY 2-3 INCHES SUPER GLUE NEAR THE RETENTION TABS, ALONG THE BOTTOM EDGE OF THE REAR FLANGE

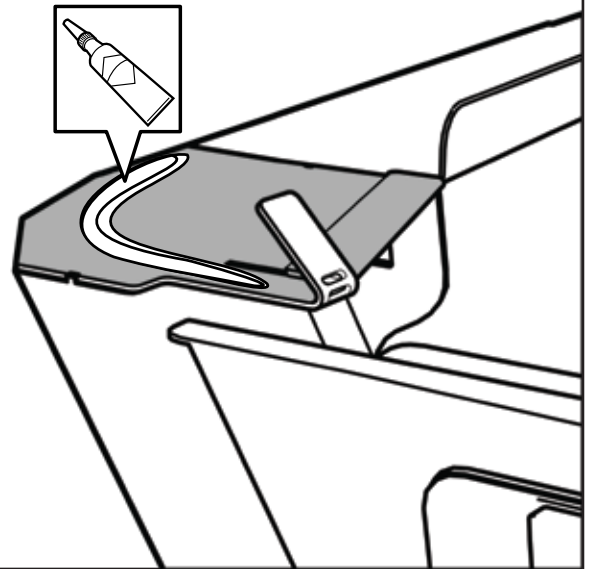
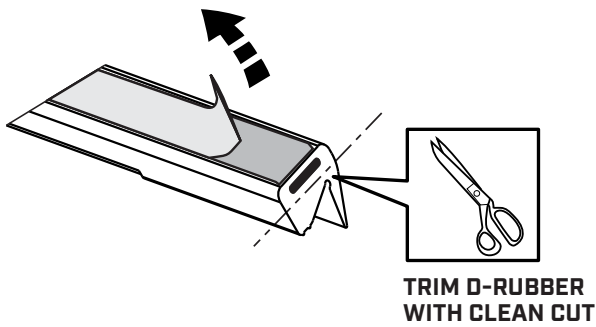

# STEP 22

FULLY INSERT THE RETENTION TAB INTO THE SLOT ON THE D-RUBBER. ENSURE THE D-RUBBER IS ORIENTED CORRECTLY WITH ITS PROFILE MATCHING THE CONTOUR OF THE REAR FLANGE.

PRESS DOWN FIRMLY ON THE TAB AND THE D-RUBBER TO BOND IT TO THE REAR FLANGE, CREATING A TIGHT SEAL.

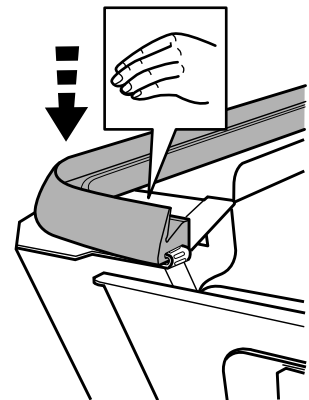
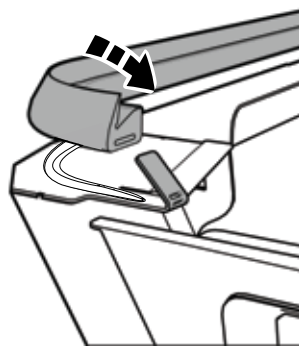

**CORRECT D-RUBBER ORIENTATION**

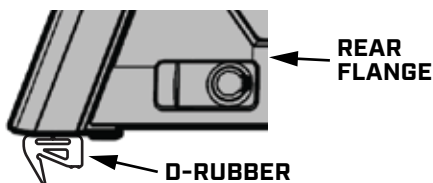

**INCORRECT D-RUBBER ORIENTATION**

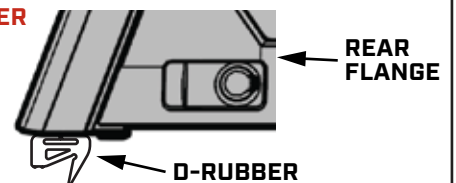

## STEP 23

ALIGN THE D-RUBBER ALONG THE SMARTCAP'S EDGE, MAINTAINING A CONSISTENT 1/8 INCH GAP FROM THE EDGE.

START FROM ONE CORNER AND WORK YOUR WAY AROUND THE CAP TO ENSURE PROPER PLACEMENT AND ALIGNMENT.

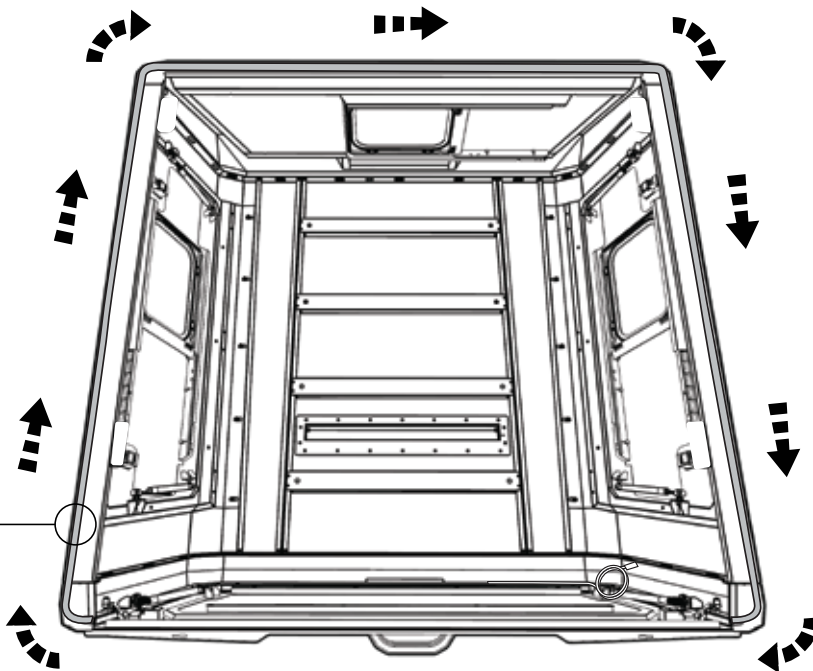

## STEP 24

TRIM ANY EXCESS D-RUBBER BEYOND THE EDGE FOR A NEAT FINISH.

APPLY 2-3 INCHES OF SUPER GLUE NEAR THE RETENTION TAB, ALONG THE BOTTOM EDGE OF THE REAR FLANGE. FULLY INSERT THE RETENTION TAB INTO THE SLOT ON THE D-RUBBER.

PRESS DOWN FIRMLY ON THE TAB AND THE D-RUBBER TO BOND IT TO THE REAR FLANGE, CREATING A TIGHT SEAL.

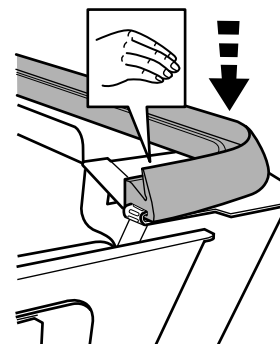
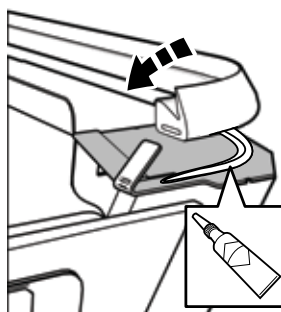
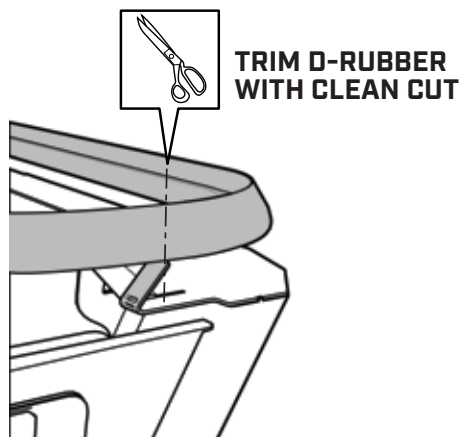

I-SHEET-NA-S3

## INSTALLATION HARDWARE

### THIN RUBBER PAD

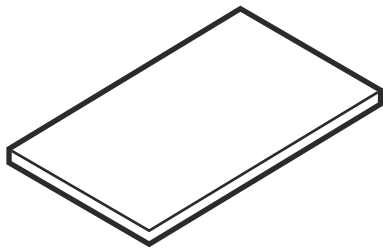

6X

### MOUNTING CLAMP

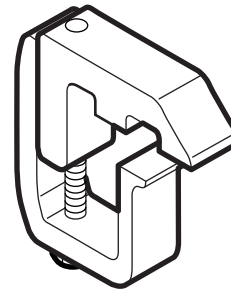

6X

### THICK RUBBER PAD

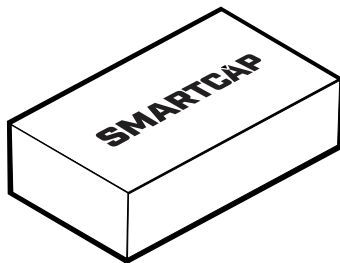

8X

### FOAM SEAL TAPE

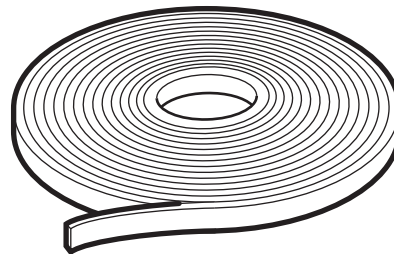

1X

## VEHICLE INSTALLATION



### IMPORTANT

- ▼ ASSISTANCE WILL BE NEEDED FOR THIS INSTALLATION. FOUR PEOPLE ARE RECOMMENDED TO LIFT THE SMARTCAP ONTO THE VEHICLE.
- ▼ AVOID PINCHING OR CRUSHING HANDS AND FINGERS.
- ▼ READ THROUGH THE ENTIRE PROCEDURE BEFORE STARTING.

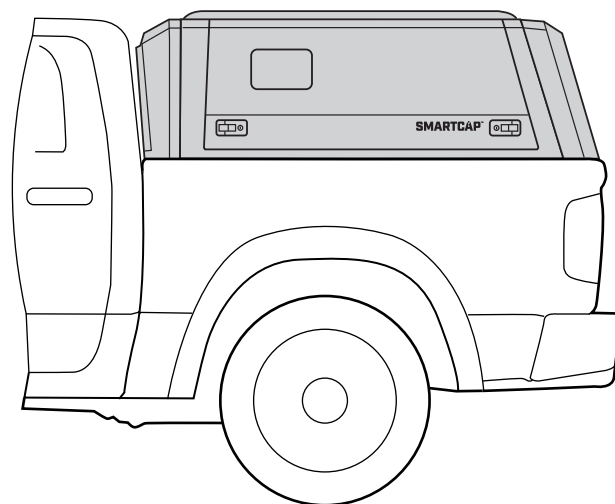

I-SHEET-NA-S3

# STEP 25



REMOVE THE ADHESIVE BACKING FROM THE THICK RUBBER PAD.

PLACE THE PADS ALONG THE INSIDE OF THE D-RUBBER AT THE INDICATED LOCATIONS.

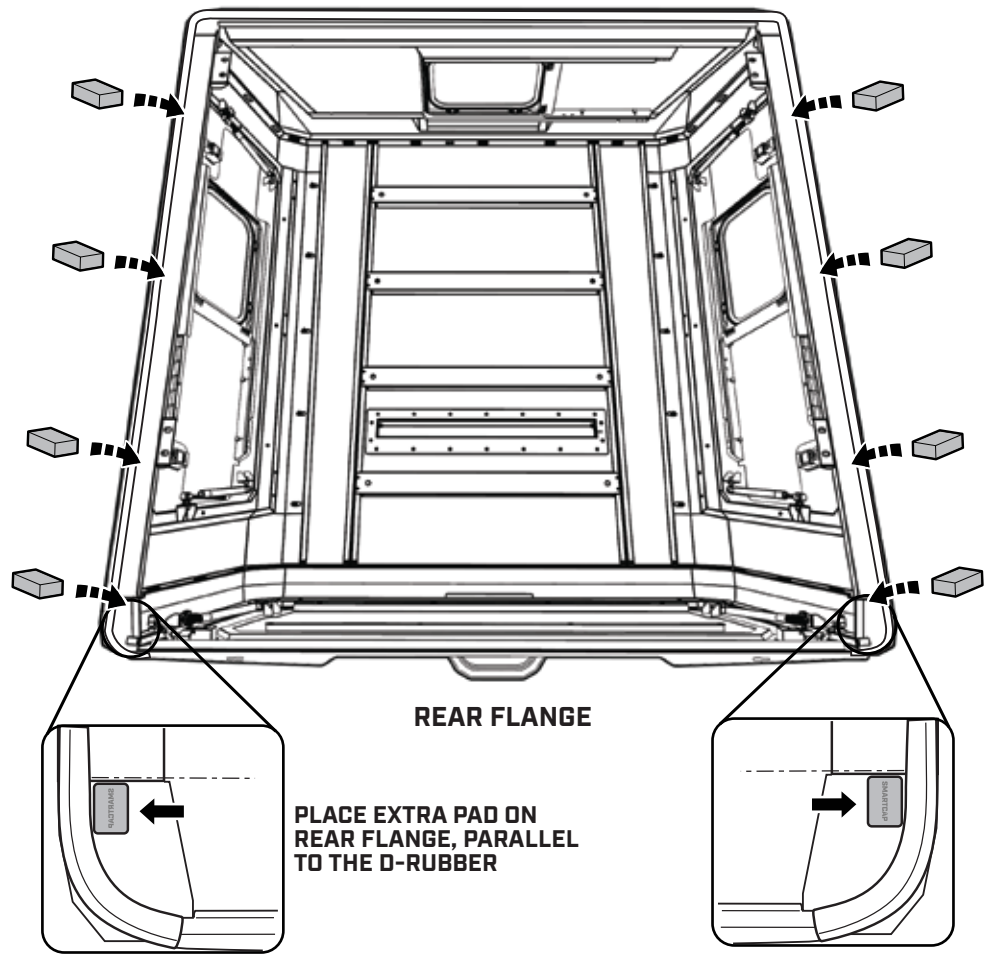
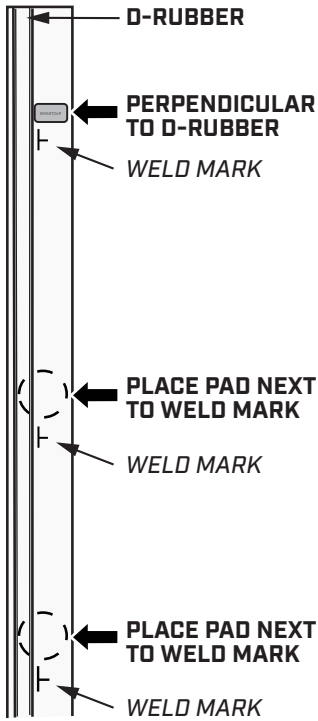

# STEP 26

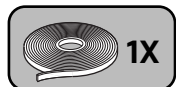

INSPECT THE TRUCK BED. IF FRONT EDGE IS LOWER THAN THE SIDES, ADD FOAM SEAL TAPE TO THE FRONT EDGE OF THE BED.

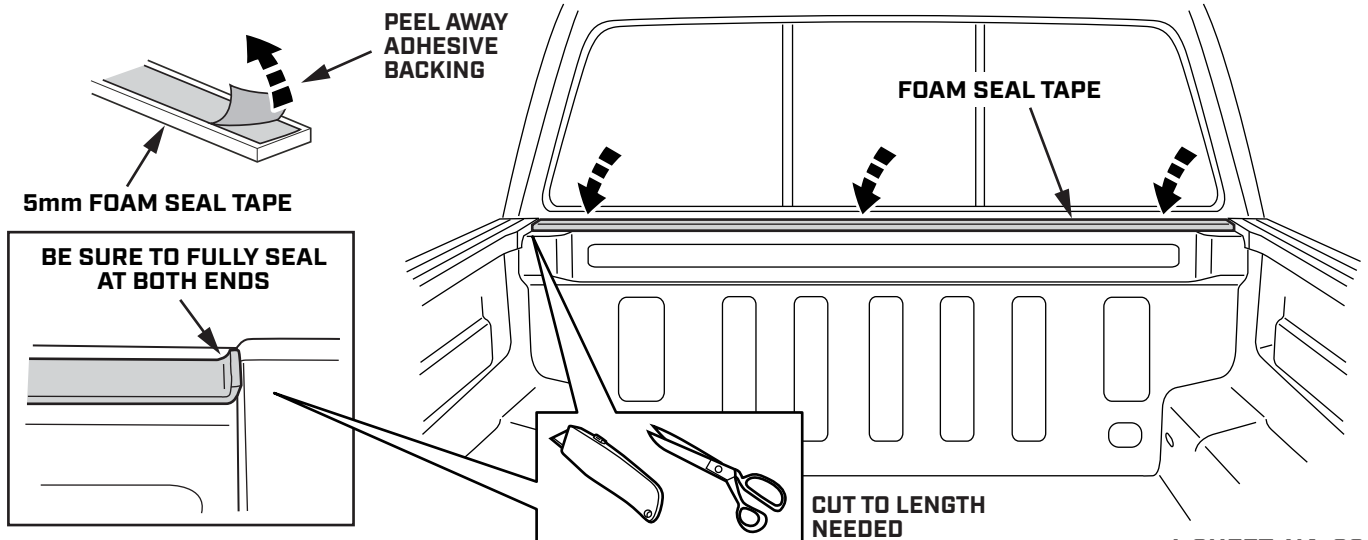

I-SHEET-NA-S3

## STEP 27

USE 4 PEOPLE TO LIFT THE ASSEMBLED SMARTCAP ONTO THE TRUCK BED.

TO AVOID DAMAGE TO THE D-RUBBER, DO NOT SLIDE THE SMARTCAP INTO PLACE.

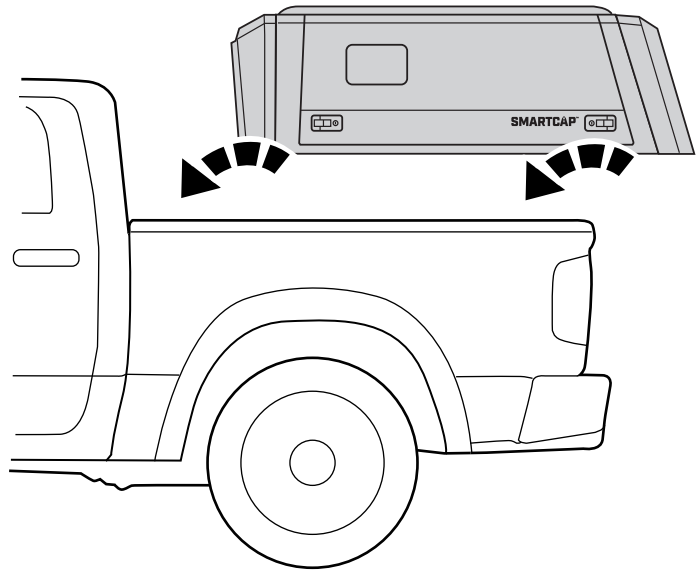

## STEP 28

CHECK THAT THE SMARTCAP IS PROPERLY POSITIONED AND CENTERED ON THE TRUCK BED.

IT'S IMPORTANT THAT THE SMARTCAP IS NOT PUSHED TOO FAR FORWARD, LEAVING A GAP BETWEEN THE SMARTCAP AND THE CAB.

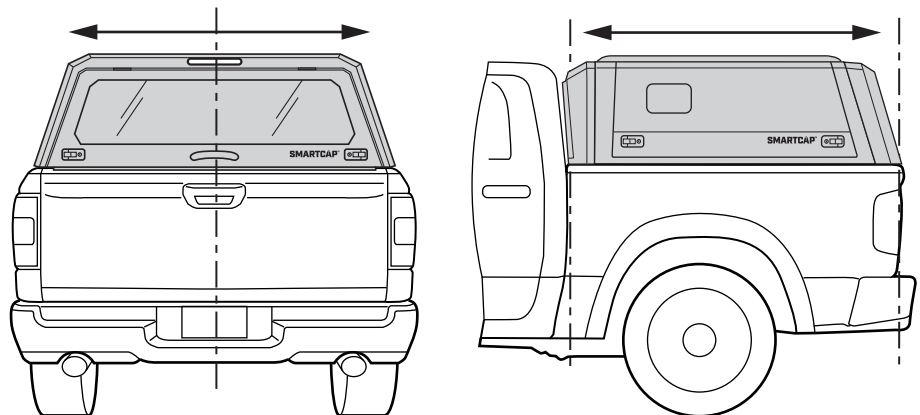

## STEP 29

WALK AROUND THE TRUCK BED TO MAKE SURE THE D-RUBBER FITMENT IS CORRECT AND THAT THE RUBBER LIP IS PROPERLY TUCKED UNDERNEATH THE CAP.

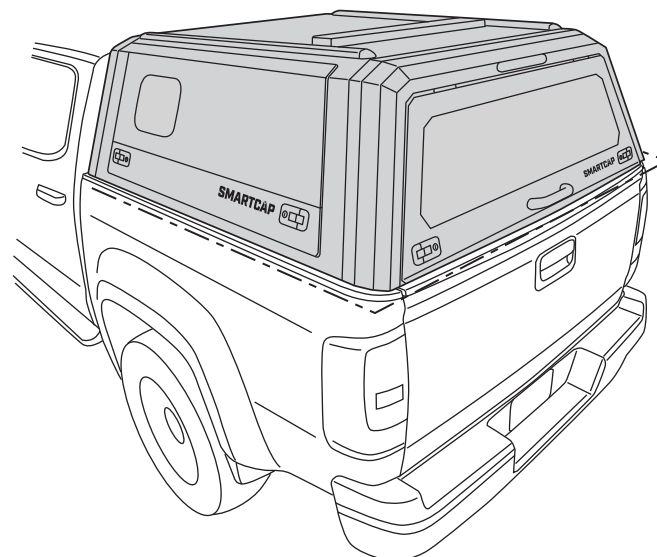

I-SHEET-NA-S3

# STEP 30

IN ORDER TO ENSURE CORRECT COMPRESSION OF THE D-RUBBER, YOU MUST TRIM TWO 1" INCH STRIPS FROM TWO DIFFERENT THIN RUBBER PADS.

WHILE LIFTING UP ON THE CAP, PLACE 1 STRIP IN EACH REAR CORNER OF THE CAP, IN BETWEEN THE THICK RUBBER PAD AND THE TRUCK BED RAILING.

**REPEAT FOR EACH SIDE**

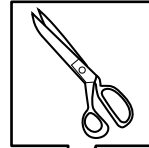

TRIM A 1" INCH STRIP FROM THIN RUBBER PAD.

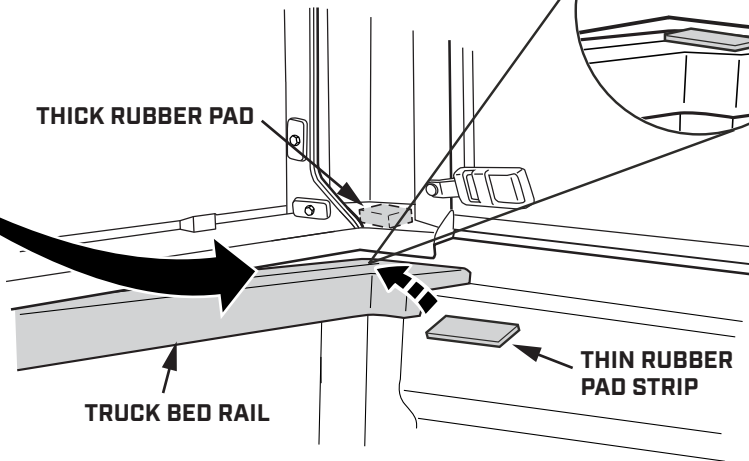
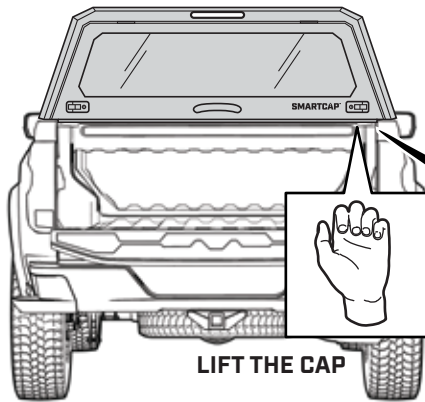
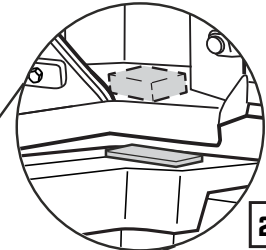
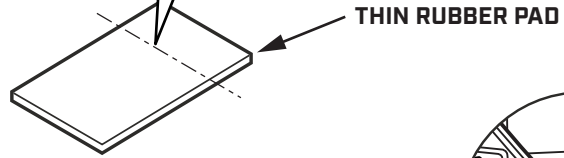

# STEP 31

CHECK THE OPERATION OF THE TAILGATE. THE LIP OF THE D-RUBBER SHOULD GRAZE THE TAILGATE WHEN OPENING AND CLOSING WITH EASE.

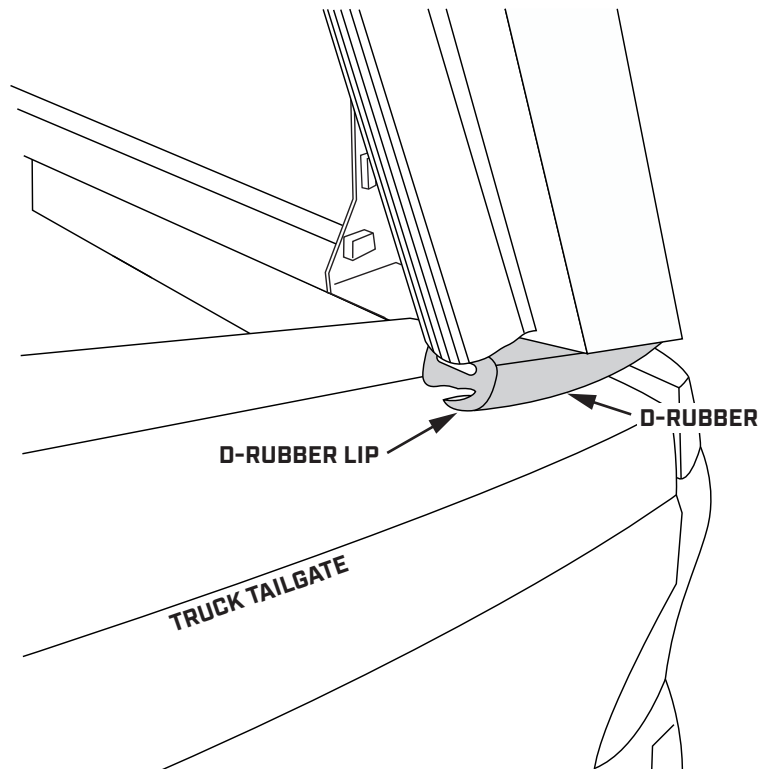

## STEP 32

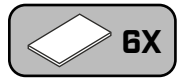

WITH THE EXCEPTION OF THE REAR CORNERS, PLACE THE THIN RUBBER PADS NEXT TO GUSSETS ON BOTH SIDES OF THE CAP.

**3 PADS PER SIDE**

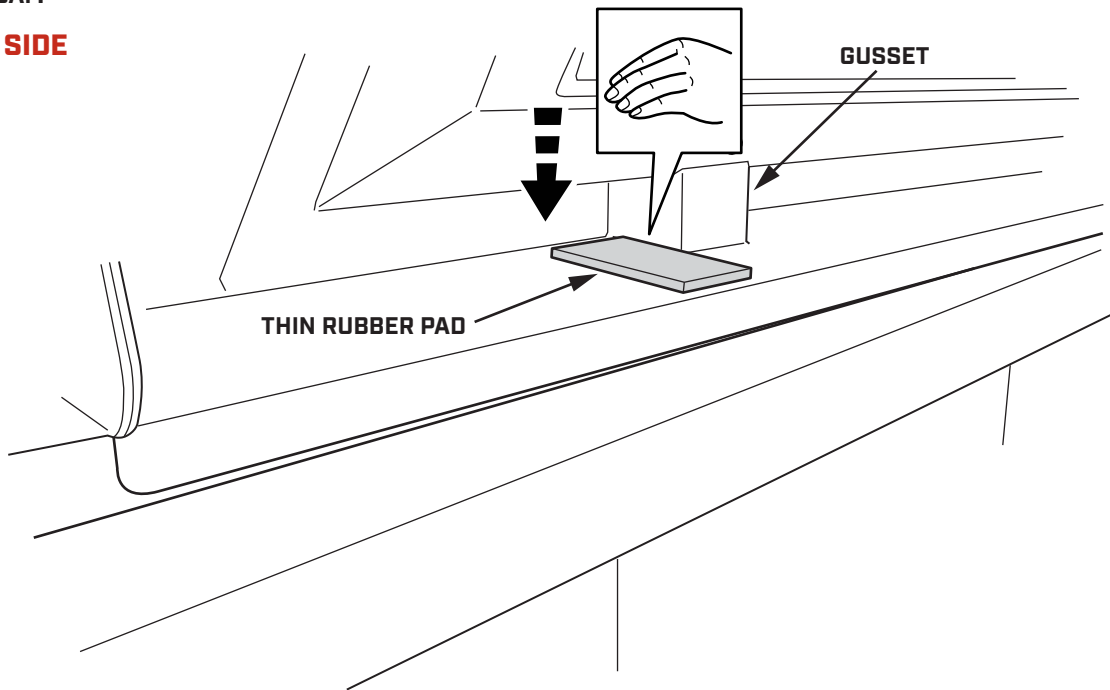

## STEP 33

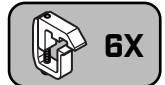

ONCE ALL PADS ARE IN PLACE, INSTALL MOUNTING CLAMPS ON TOP OF THIN RUBBER PADS USING TORQUE WRENCH AND 13MM SOCKET. TIGHTEN CLAMPS TO 4.4 FT. LBS. [6 NEWTON METERS]

**3 CLAMPS PER SIDE**

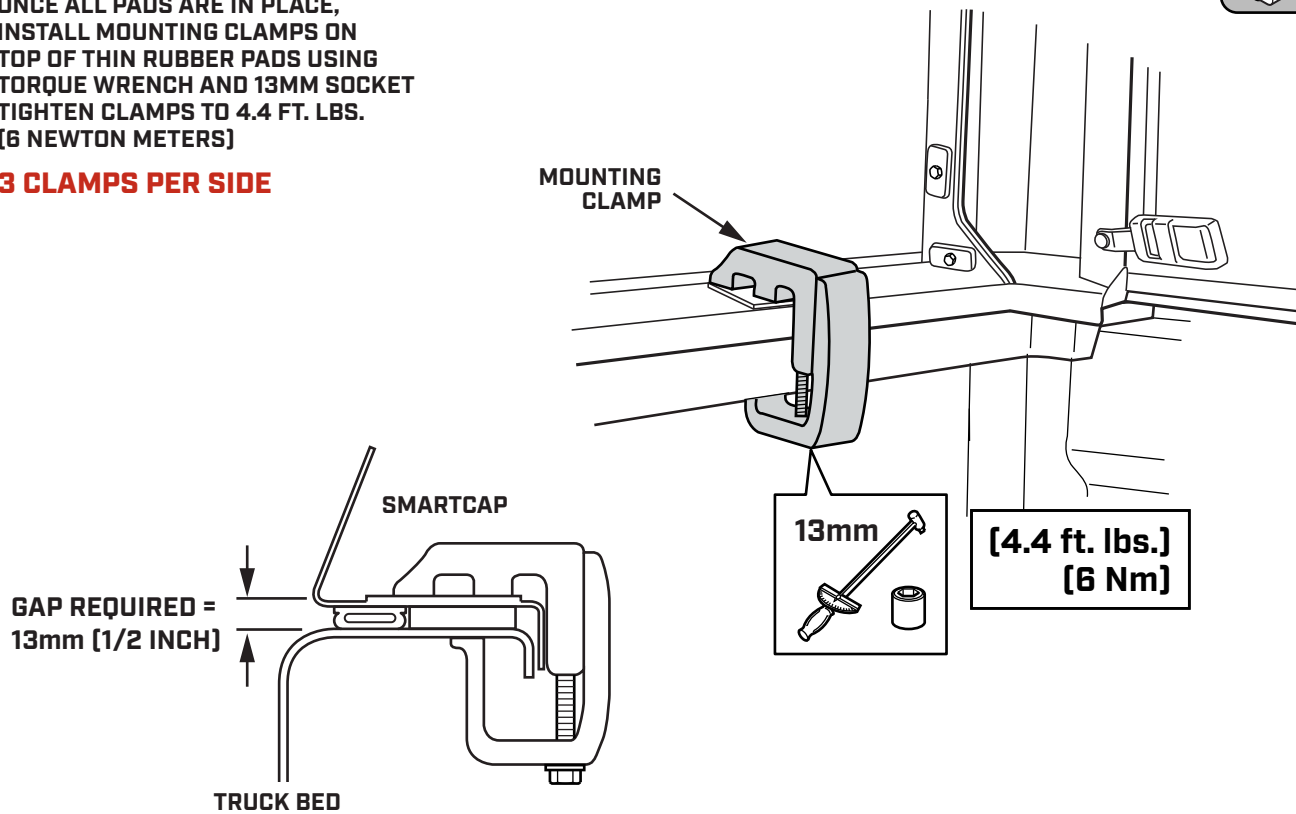

I-SHEET-NA-S3

## THIRD BRAKE LIGHT CONNECTOR INSTALLATION



### IMPORTANT

- ▼ BE SURE THE VEHICLE IS TURNED OFF FOR THIS INSTALLATION.
- ▼ READ THROUGH THE ENTIRE PROCEDURE BEFORE STARTING AND FOLLOW THE STEPS CAREFULLY TO ENSURE THE THIRD BRAKE LIGHT WILL FUNCTION PROPERLY.
- ▼ USE A TEST LIGHT TO CHECK FOR SUCCESSFUL INSTALLATION.
- ▼ DETERMINE WHICH CONNECTOR HARNESS YOUR FITMENT KIT CONTAINS.

## STEP 34-56

ZORG HARNESS 002-218/100-219

### T-HARNESS

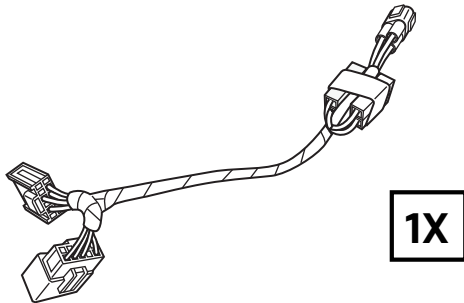

### CONNECTOR HARNESS

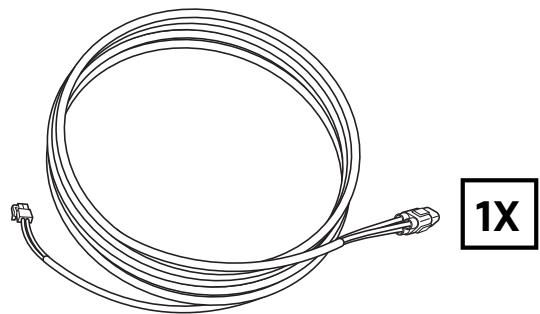

## STEP 57-68

ZORG HARNESS 100-226

### SPLICE TERMINAL

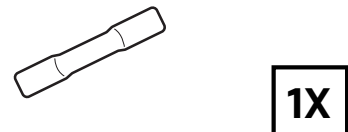

### CONNECTOR HARNESS

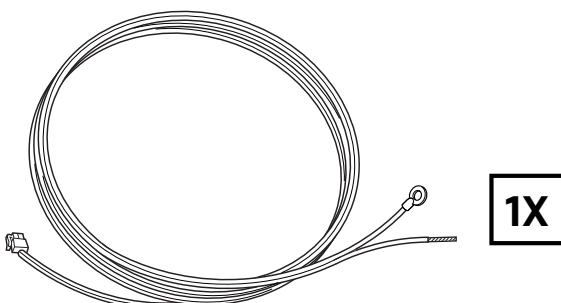

### PLASTIC SHEATH

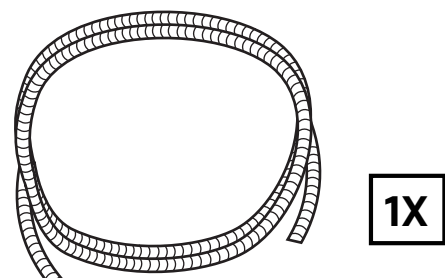

I-SHEET-NA-S3

## STEP 34

STARTING FROM THE UPPER CORNERS,  
GENTLY PRY AND RELEASE THE CLIPS  
TO REMOVE THE DRIVER-SIDE KNEE PANEL.

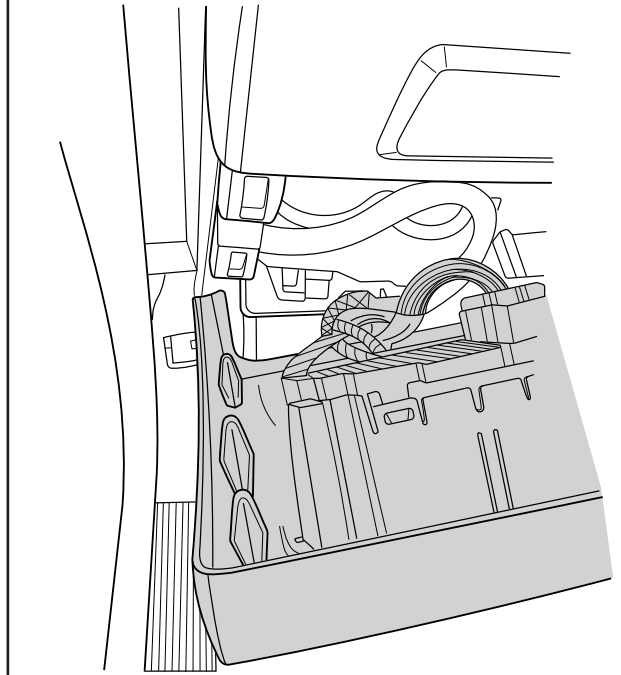
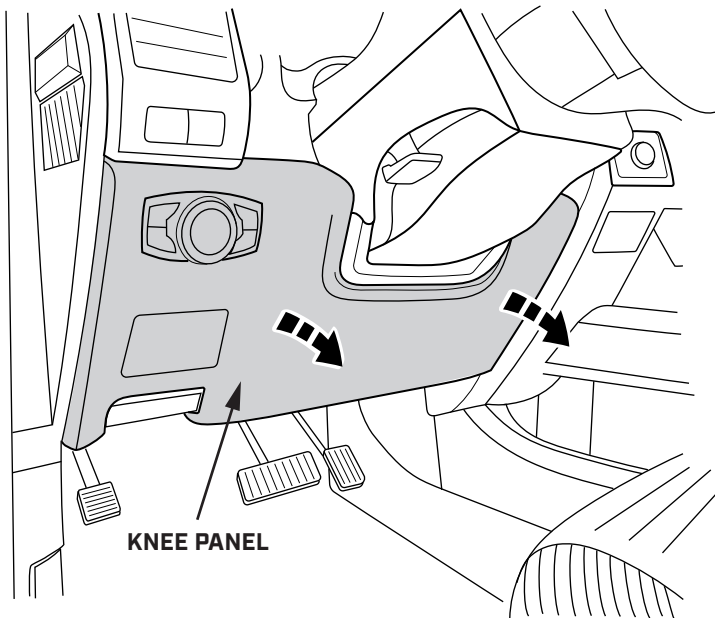

## STEP 35

USE A 10MM SOCKET WRENCH TO  
REMOVE THE 4 BOLTS HOLDING  
THE METAL PLATE.

REMOVE THE METAL PLATE.

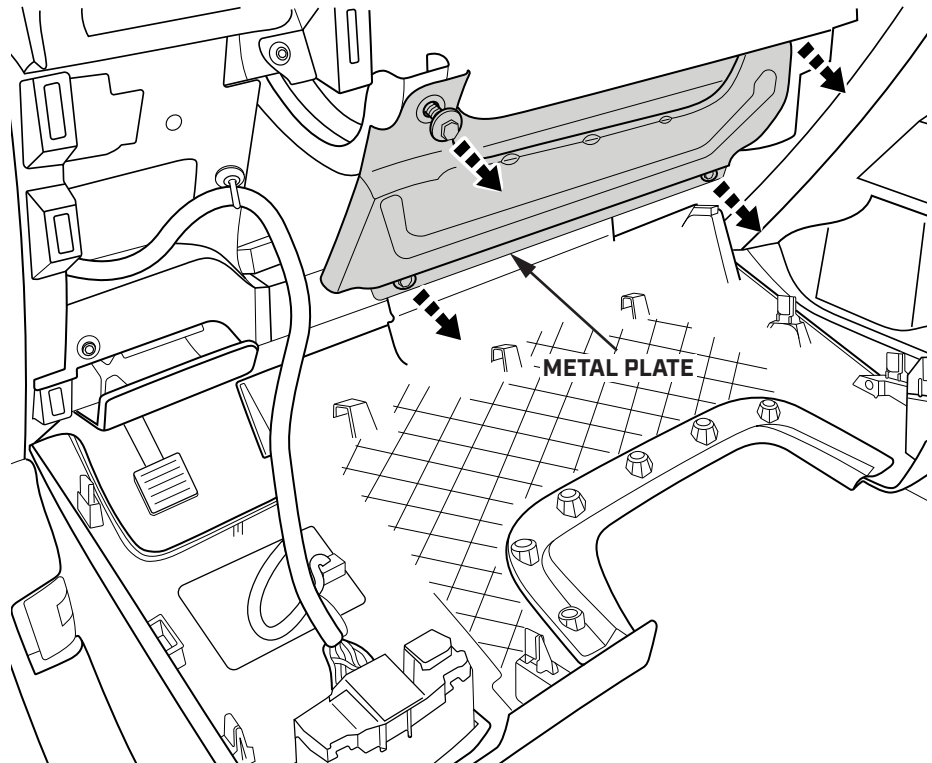

## STEP 36

LOCATE THE GREY CONNECTOR ON THE INSIDE OF THE CENTER CONSOLE, BEHIND THE DRIVE SELECTOR SWITCH.

DISCONNECT THE GREY CONNECTOR FROM THE SOCKET.

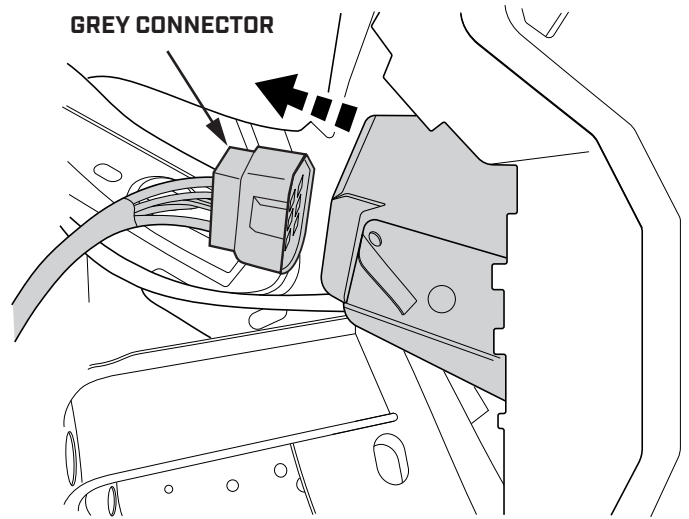
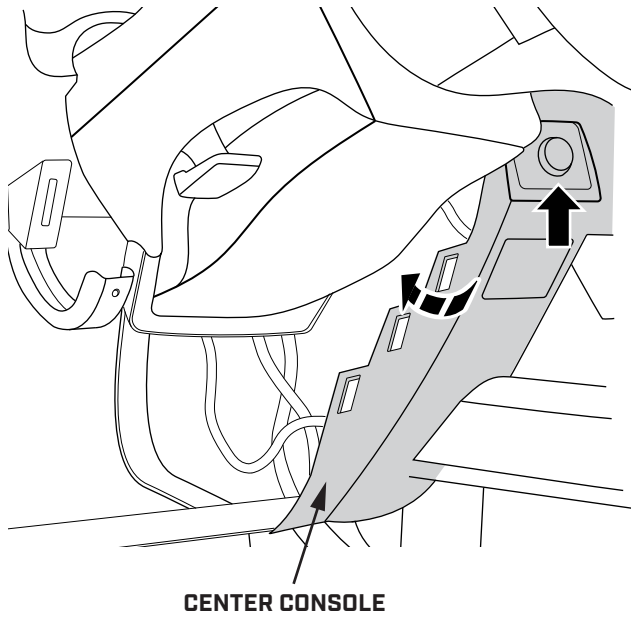

## STEP 37

CONNECT THE FEMALE END OF THE T-HARNESS TO THE GREY CONNECTOR.

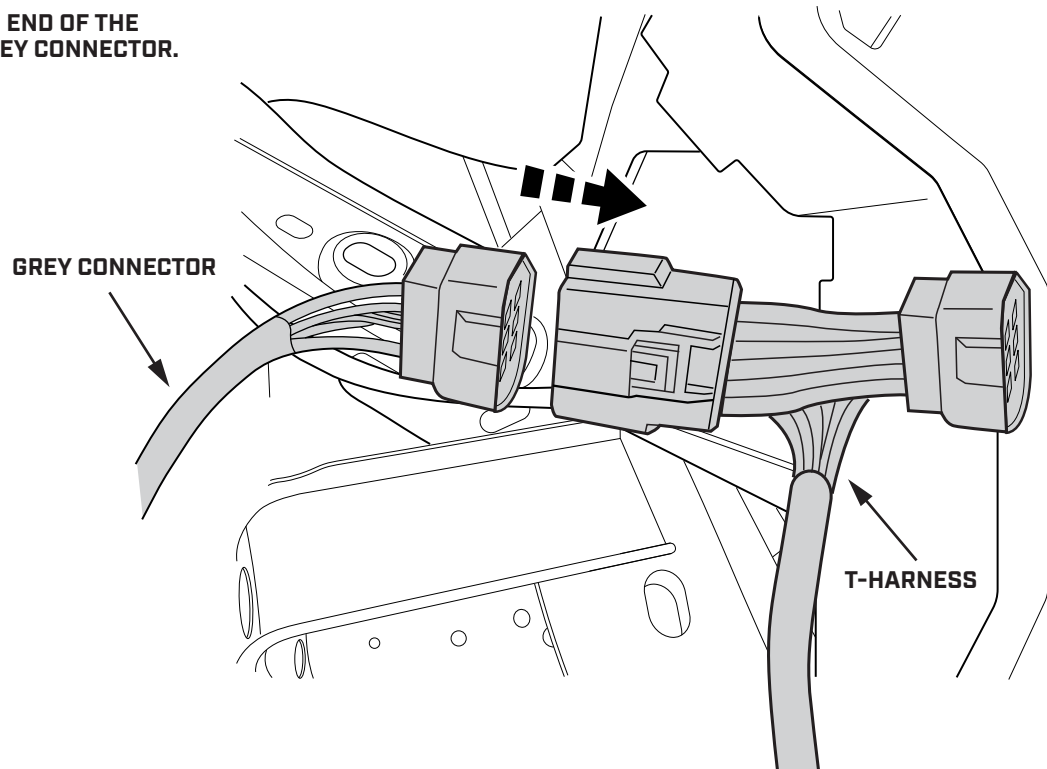

## STEP 38

PLUG THE MALE END OF THE T-HARNESS INTO THE SOCKET LOCATED ON THE INSIDE OF THE CENTER CONSOLE.

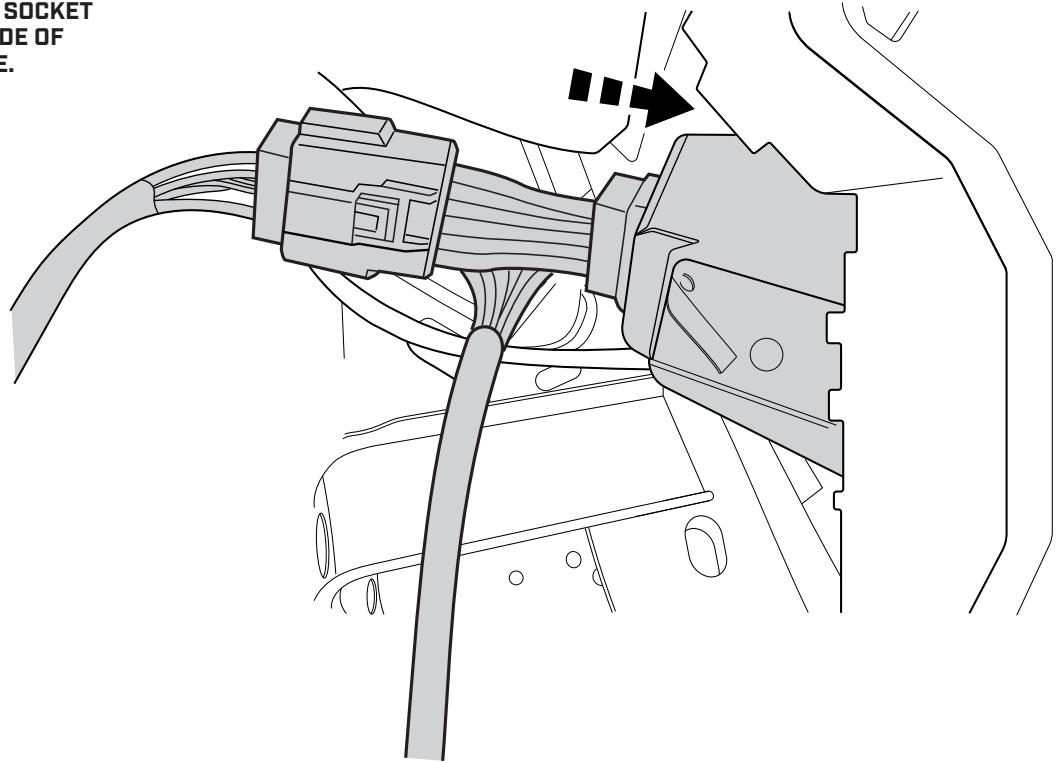

## STEP 39

REINSTALL THE METAL PLATE AND KICK PANEL.

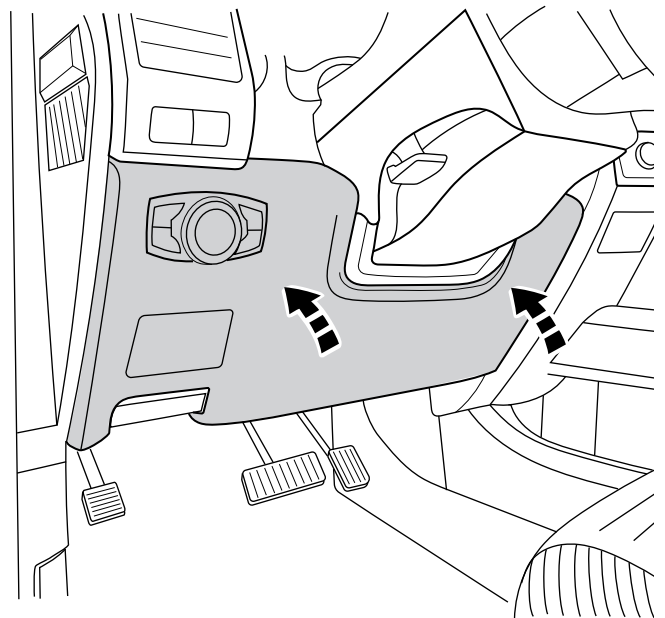
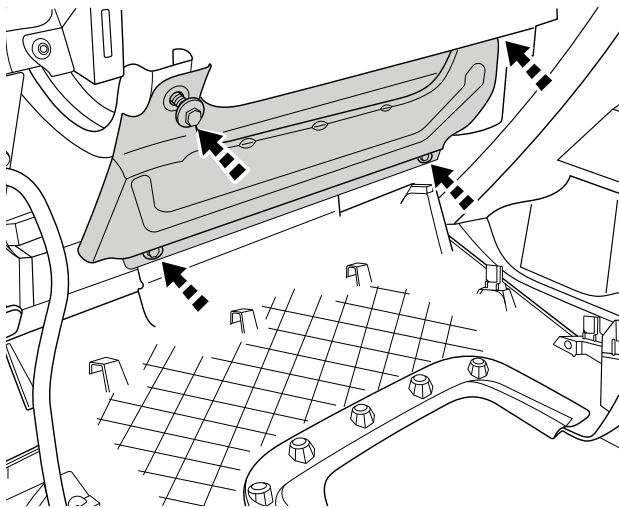

I-SHEET-NA-S3

## STEP 40

USING A PLASTIC PRY TOOL, CAREFULLY PRY OFF THE DOOR SILL TRIM PLATE ON THE DRIVER SIDE

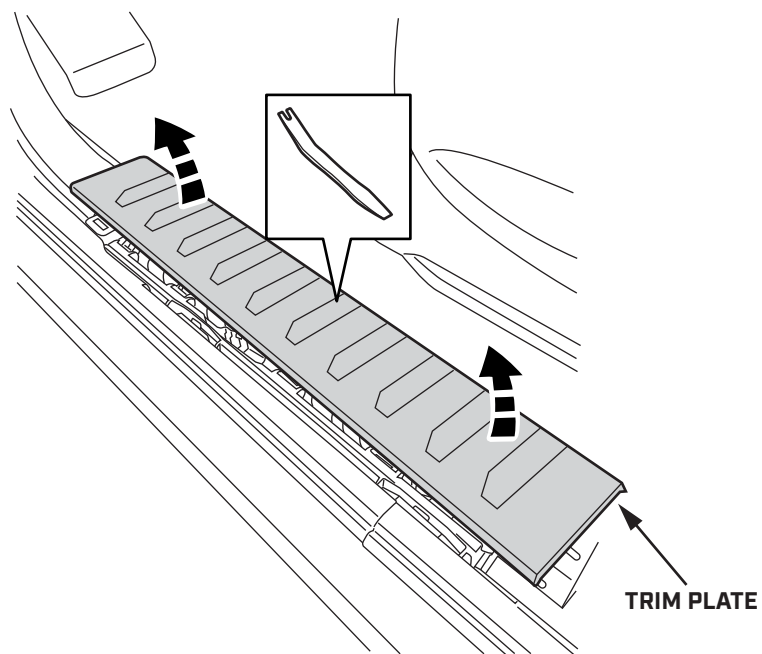

## STEP 41

UNDER THE DRIVER SIDE DASH, LOCATE THE 3-PIN PLUG OF THE T-HARNESS.

PLUG THE CONNECTOR HARNESS INTO THE 3-PIN PLUG OF THE T-HARNESS.

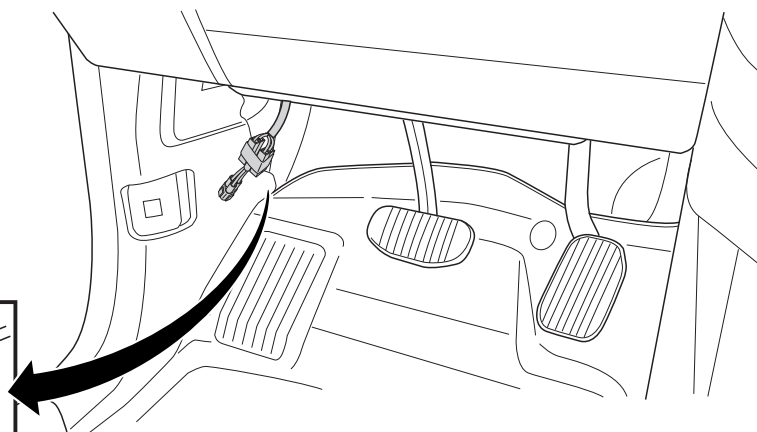
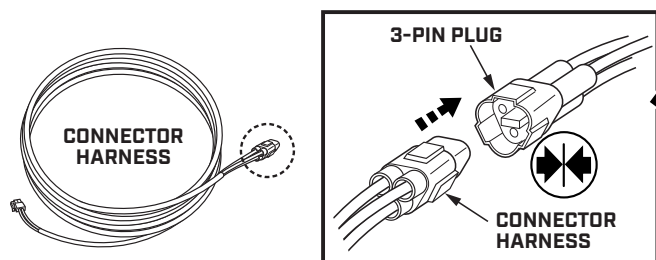

## STEP 42

TUCK THE HARNESSES UNDER THE EDGE OF THE OUTER FOOT WELL KICK PANEL AND ROUTE DOWN TOWARDS THE DOOR SILL.

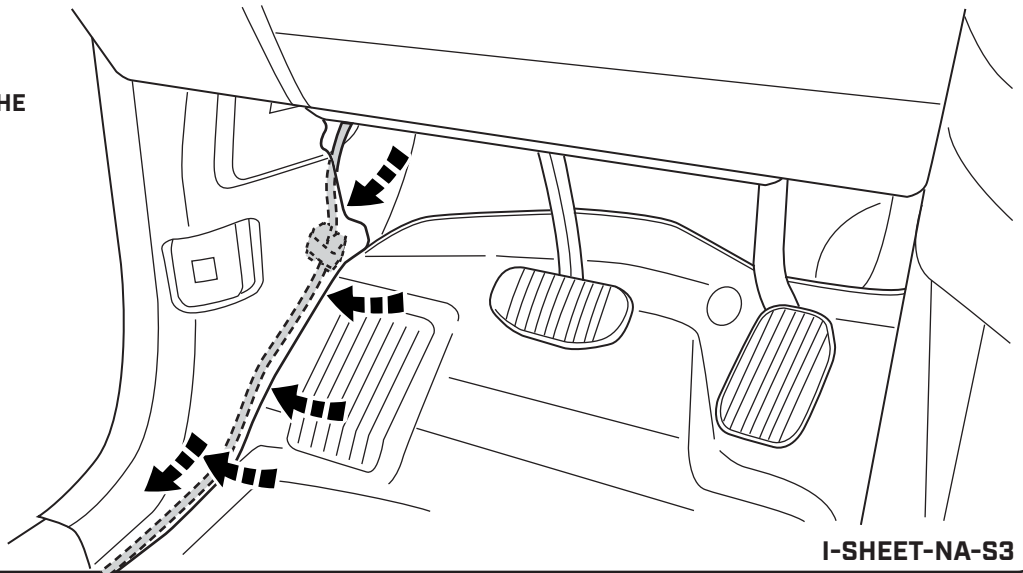

I-SHEET-NA-S3

## STEP 43

UNDERNEATH THE CARPET LINER, THERE WILL BE A RUBBER GROMMET IN THE METAL FLOOR.

LOCATE THIS GROMMET FROM UNDERNEATH THE VEHICLE.

IF NEEDED, DRILL OR CUT A SMALL OPENING THROUGH THE RUBBER GROMMET.

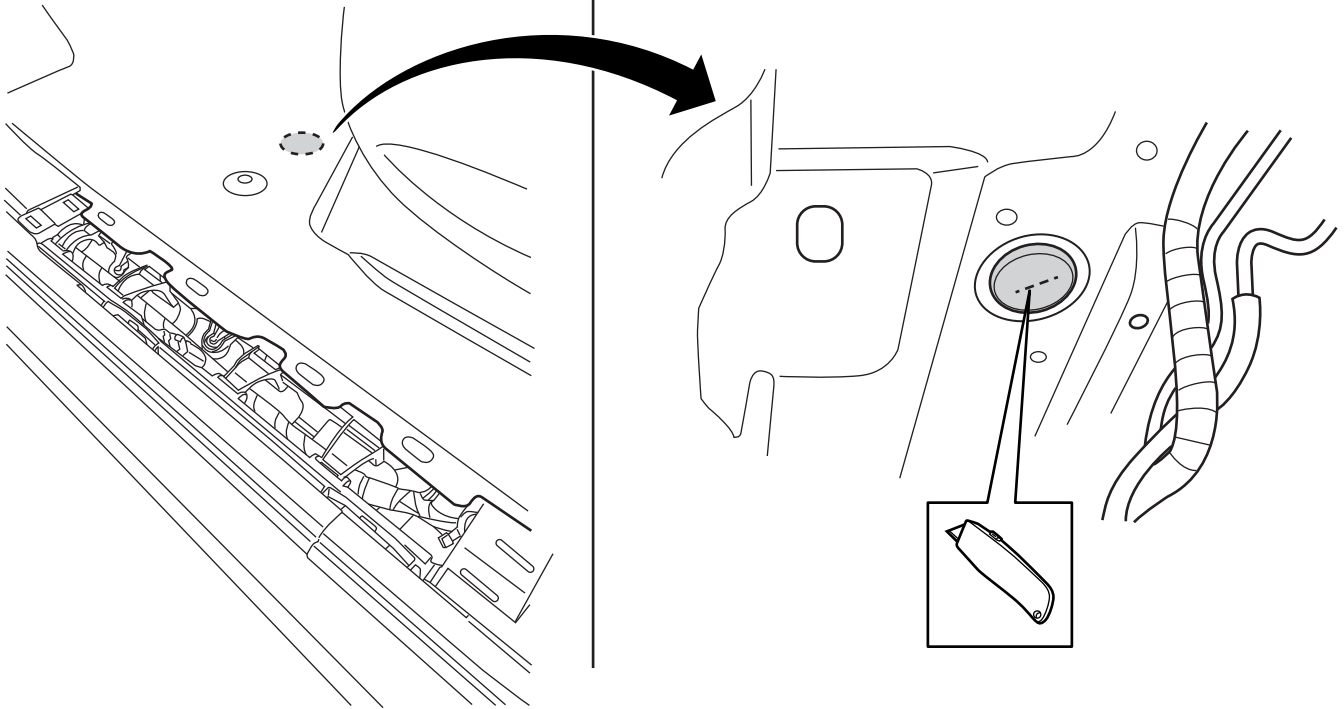

## STEP 44

ROUTE THE 2-PIN PLUG AT THE END OF CONNECTOR HARNESS UNDERNEATH THE CARPET LINER AND THROUGH THE OPENING IN THE GROMMET.

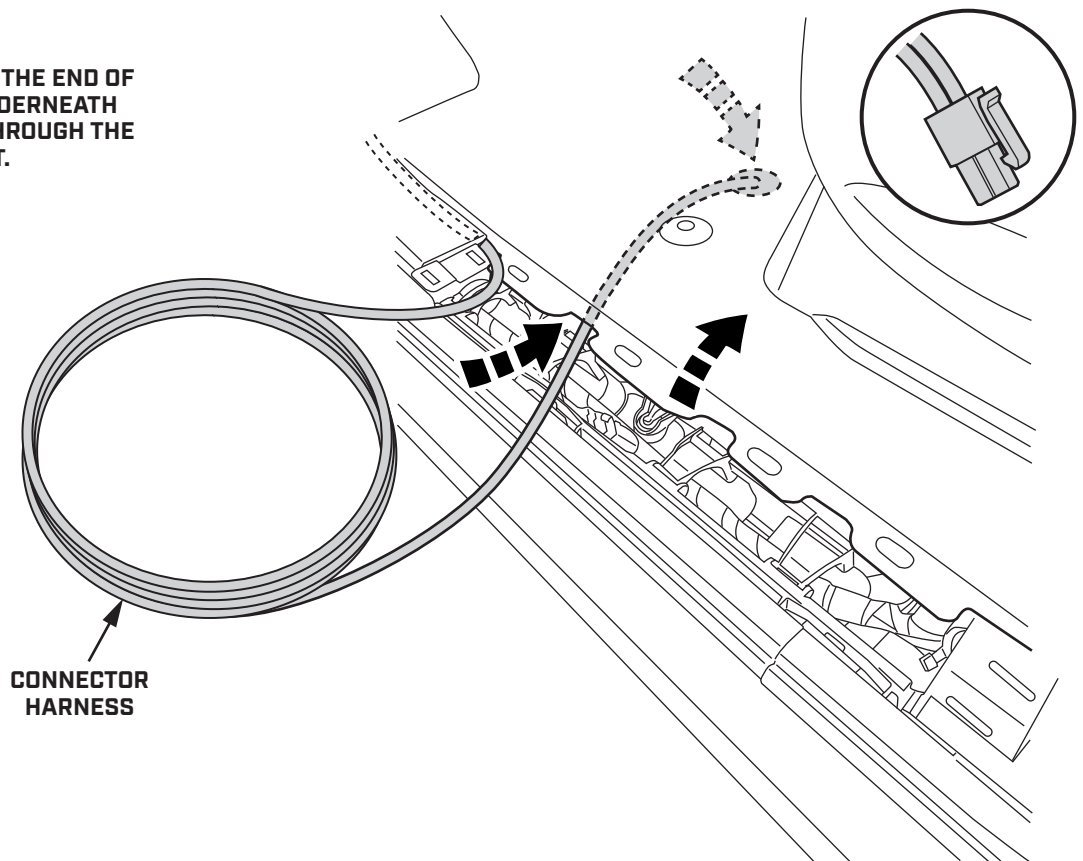

I-SHEET-NA-S3

## STEP 45

CAREFULLY PULL THE ENTIRE LENGTH OF THE CONNECTOR HARNESS DOWN THROUGH THE GROMMET.

IT IS RECOMMENDED THAT A SEALING COMPOUND BE APPLIED TO THE OPENING FOR WEATHER AND DIRT PROTECTION.

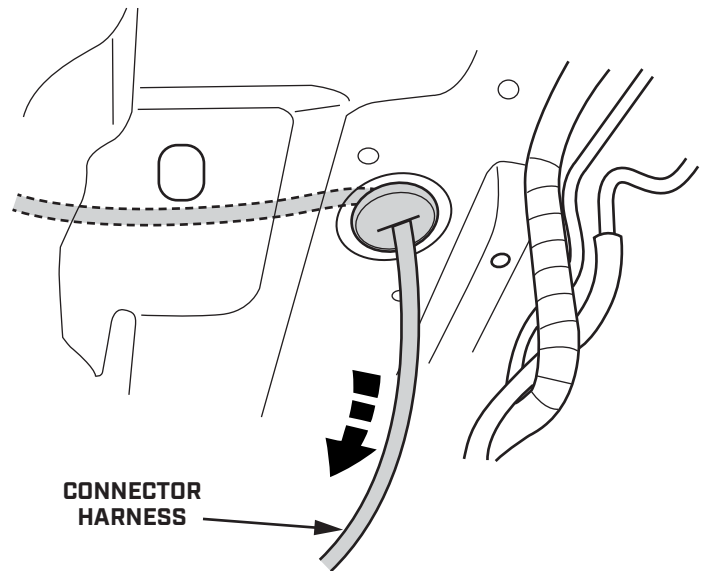

## STEP 46

FROM UNDERNEATH THE VEHICLE, BEGIN ROUTING THE CONNECTOR HARNESS OVER THE TOP OF THE DRIVER SIDE FRAME RAIL.

SECURE THE HARNESS ALONG THE OUTSIDE OF THE FRAME WITH CABLE TIES AS SHOWN.

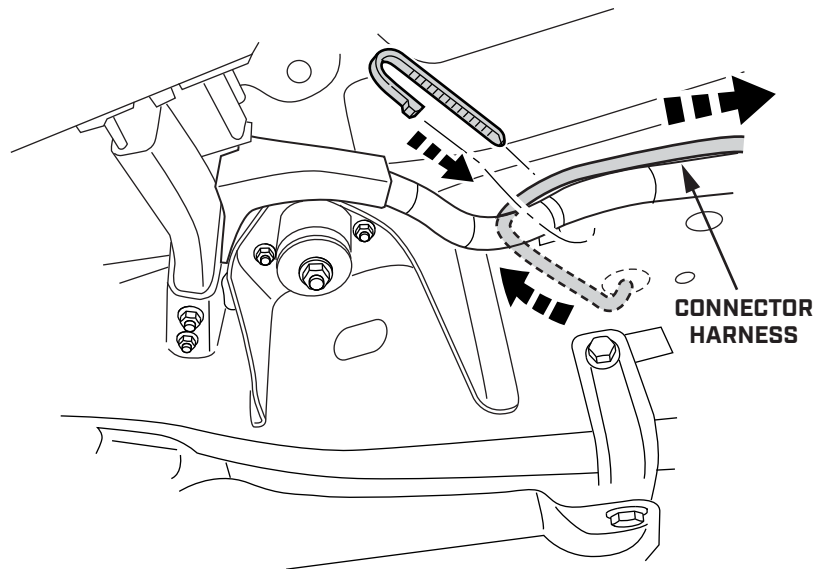
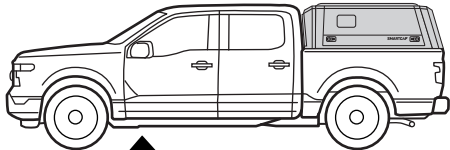

## STEP 47

CONTINUE ROUTING THE CONNECTOR HARNESS TOWARDS THE REAR OF THE VEHICLE, SECURING TO THE VEHICLE WITH CABLE TIES WHEN NECESSARY.

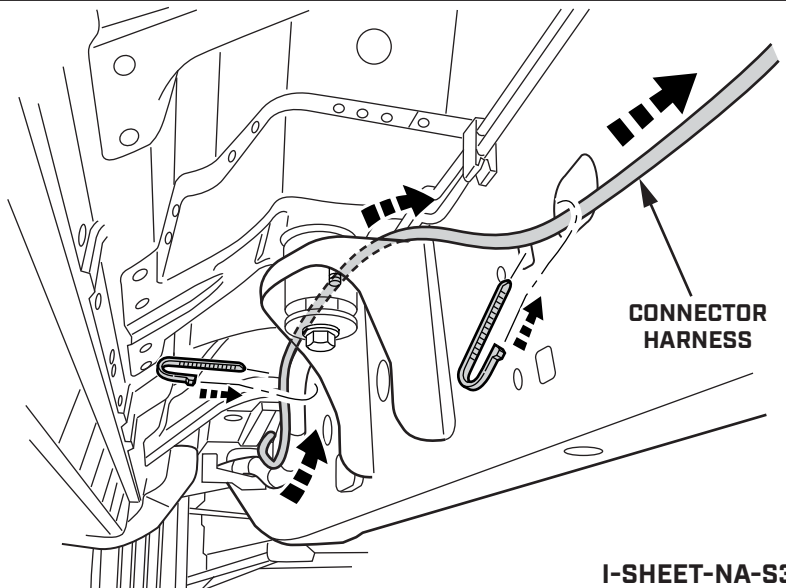
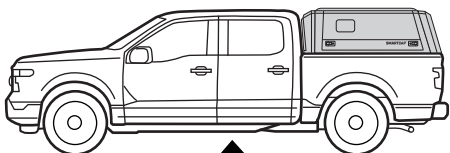

I-SHEET-NA-S3

# STEP 48

ROUTE THE CONNECTOR HARNESS UP AND OVER THE REAR WHEEL WELL.

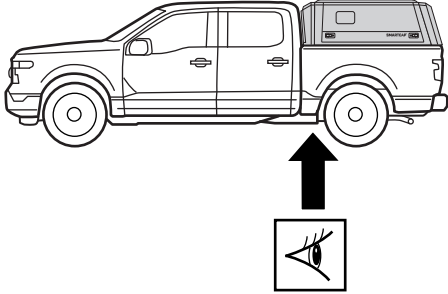

CONNECTOR HARNESS

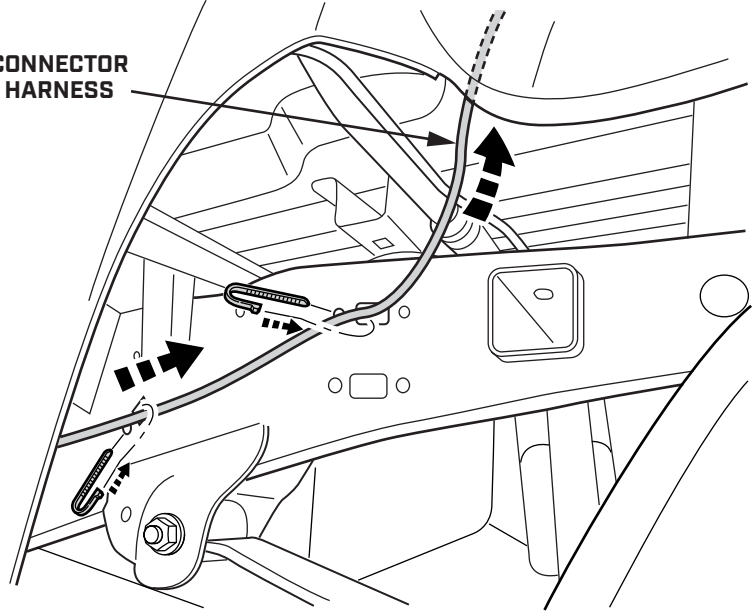

# STEP 49

ROUTE THE CONNECTOR HARNESS DOWN OVER THE BACK OF THE REAR WHEEL WELL AND SECURE WITH CABLE TIE AS SHOWN.

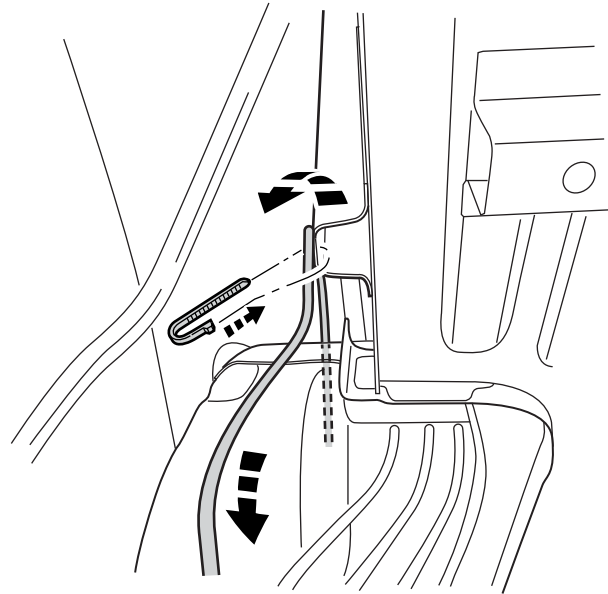
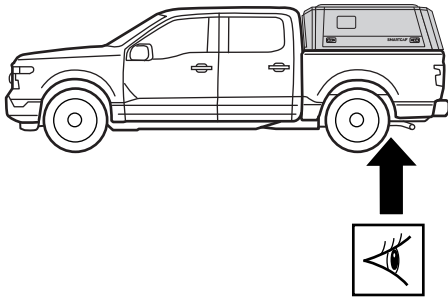

# STEP 50

REMOVE THE BOLTS HOLDING THE DRIVER SIDE TAILLIGHT ASSEMBLY

PLACE THE TAILLIGHT CAREFULLY ON THE TAILGATE. DO NOT UNPLUG ANY CONNECTORS

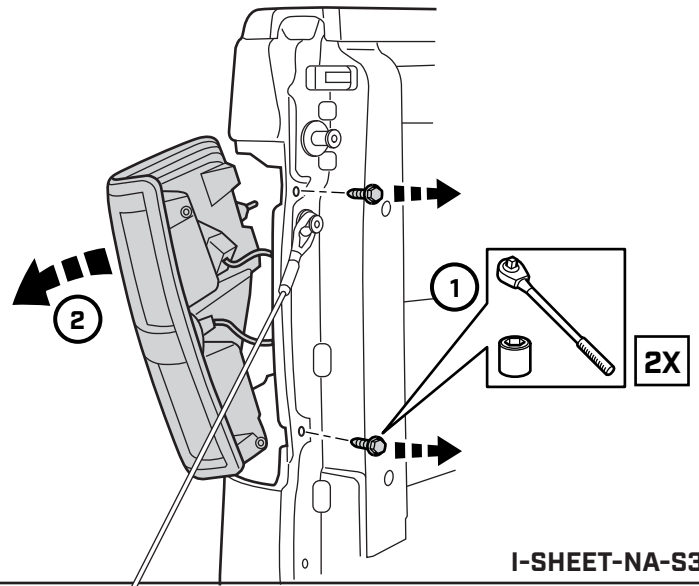

I-SHEET-NA-S3

## STEP 51

ROUTE THE CONNECTOR HARNESS UP TOWARDS THE TAILLIGHT CAVITY.

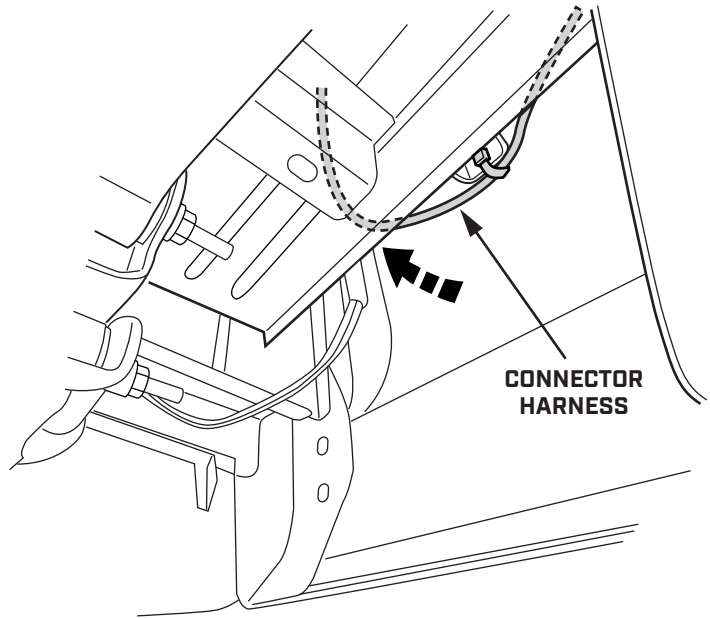
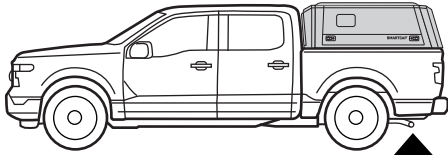

## STEP 52

CAREFULLY PULL THE CONNECTOR HARNESS OUT THROUGH THE TAILLIGHT CAVITY.

ROUTE THE CONNECTOR HARNESS UP AND OUT THROUGH THE HOLE IN THE SIDE OF THE BED.

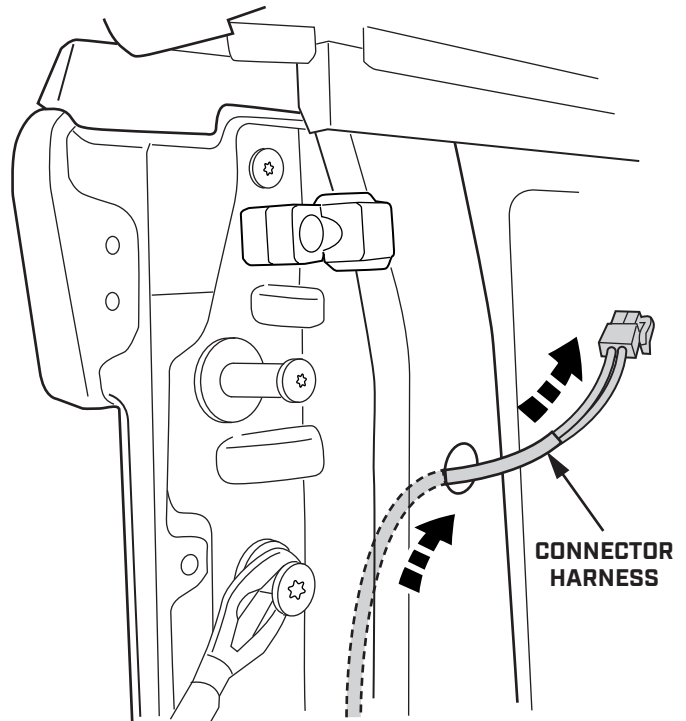
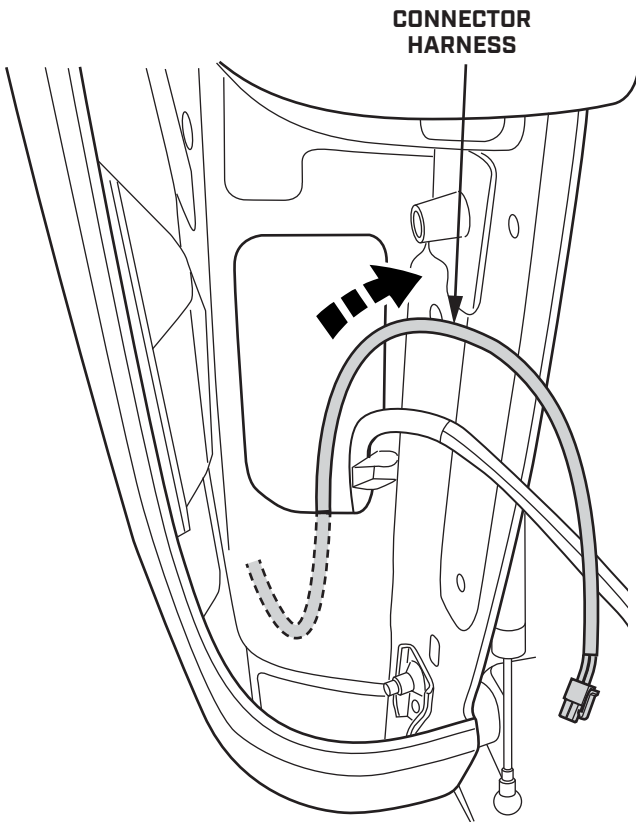

I-SHEET-NA-S3

## STEP 53

LOCATE AND DISCONNECT THE THIRD BRAKE LIGHT EXTENSION HARNESS FROM THE INSIDE BACK LEFT CORNER OF THE SMARTCAP.

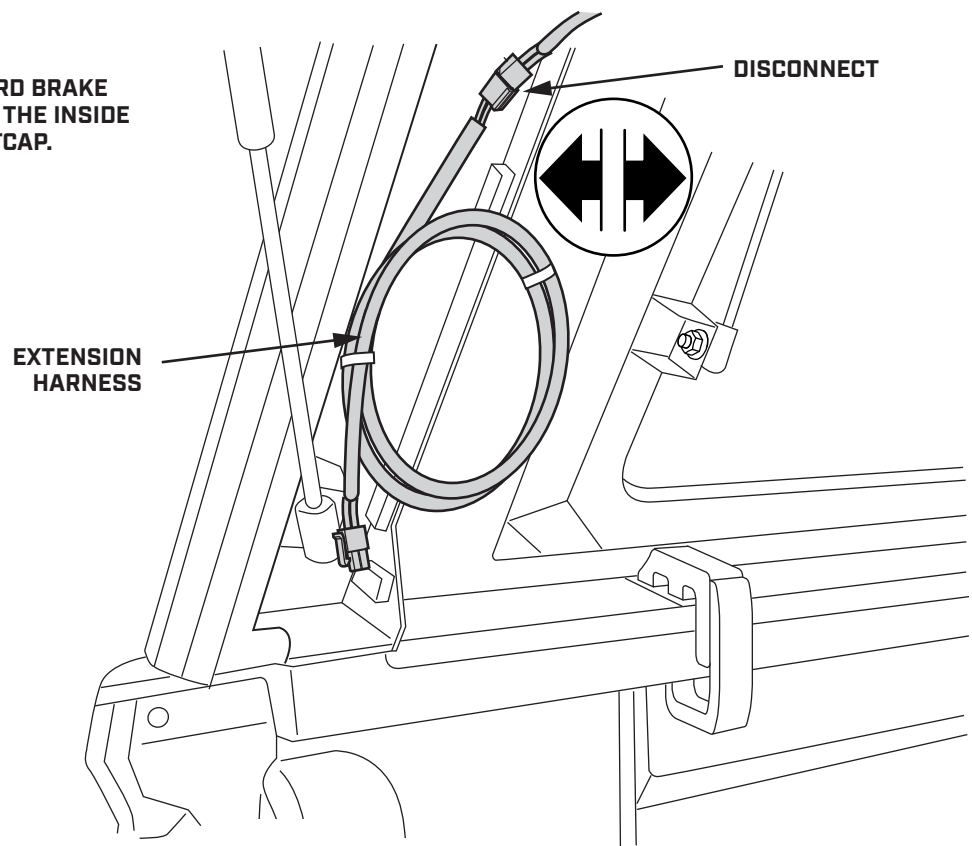

## STEP 54

CONNECT THE 2-PIN PLUG FROM THE CONNECTOR HARNESS TO THE THIRD BRAKE LIGHT HARNESS.

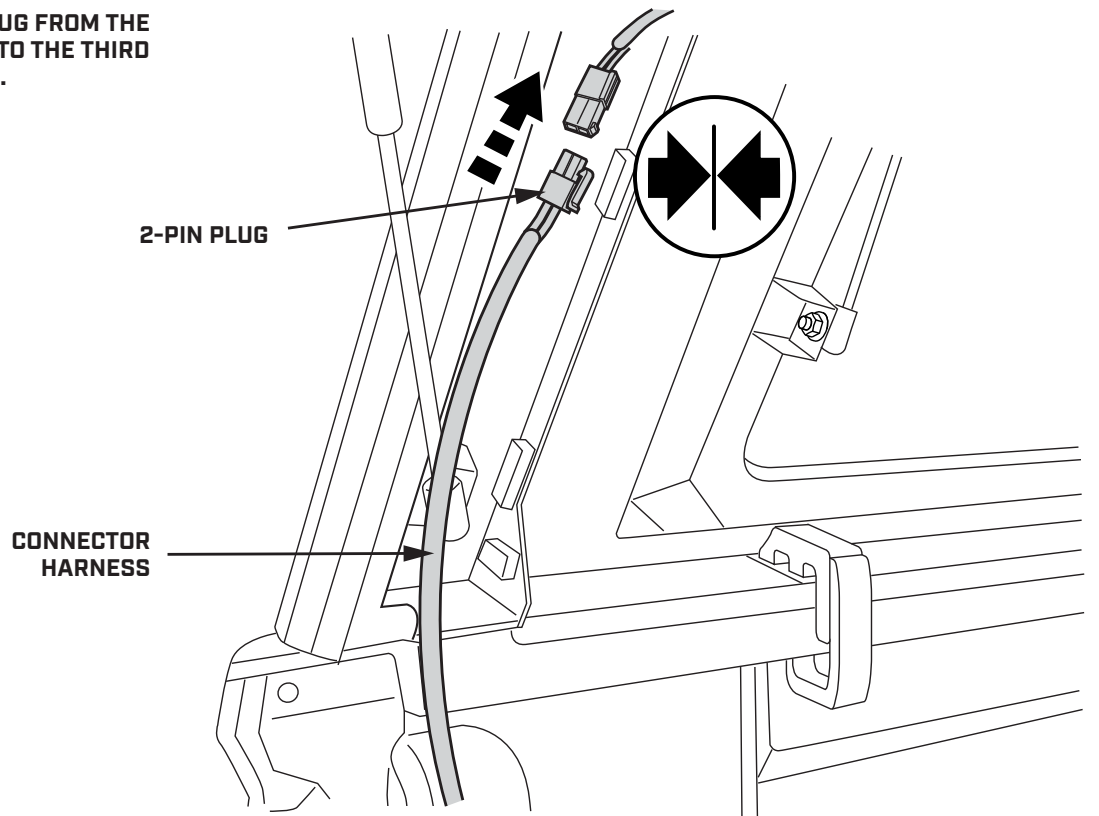

## STEP 55

REINSTALL THE TAILLIGHT ASSEMBLY.

BUNDLE EXTRA HARNESS LENGTH IN THE TAIL LIGHT CAVITY AND SECURE WITH A CABLE TIE.

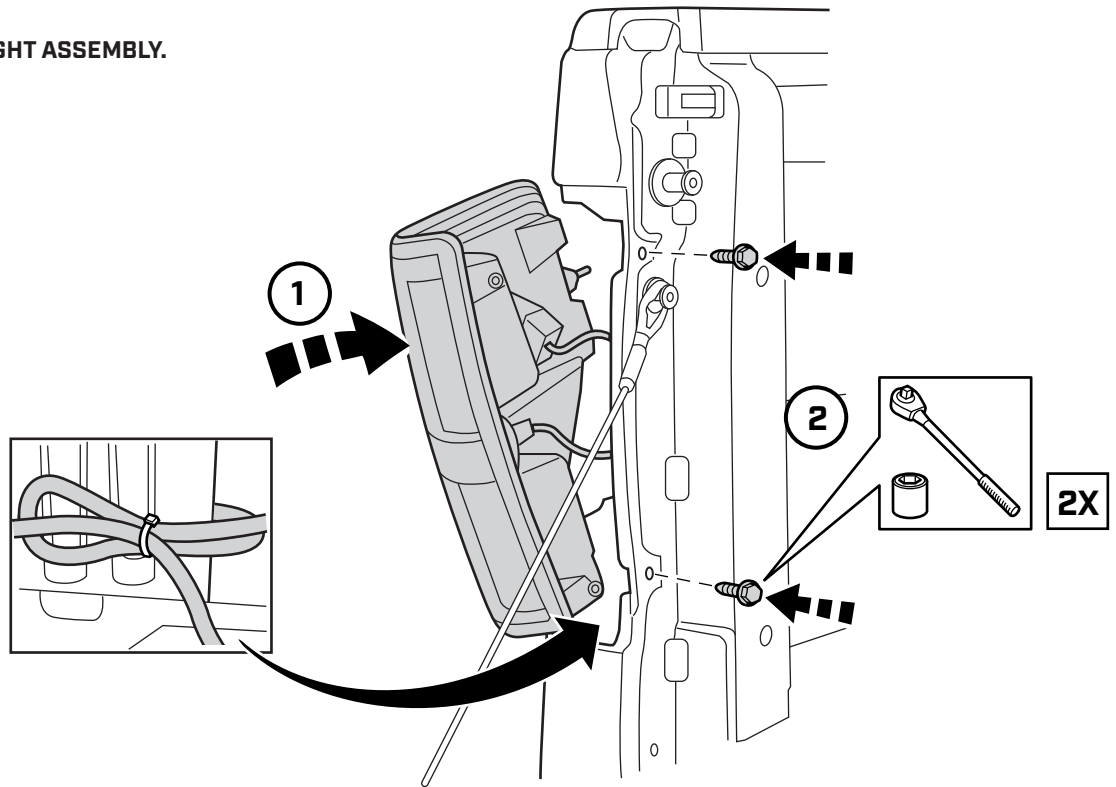

## STEP 56



### TEST YOUR BRAKE LIGHTS & TURN SIGNALS

- ▼ START THE TRUCK. SOME MODELS MAY TAKE UP TO 30 SECONDS FOR THE VEHICLE TO DETECT THE NEW CONNECTION.
- ▼ CHECK THE BRAKE LIGHTS AND TURN SIGNALS TO BE SURE THEY ARE FUNCTIONING PROPERLY.
- ▼ ONCE YOU HAVE CONFIRMED THAT THE LIGHTS ARE WORKING CORRECTLY, SECURE THE HARNESS WITH CABLE TIES.
- ▼ BE SURE NOT TO INTERFERE WITH ANY MOVING PARTS ON THE VEHICLE.

# STEP 57

LOCATE THE HIGH MOUNT STOP LAMP WIRE SITUATED WITHIN THE REAR BUMPER ASSEMBLY.

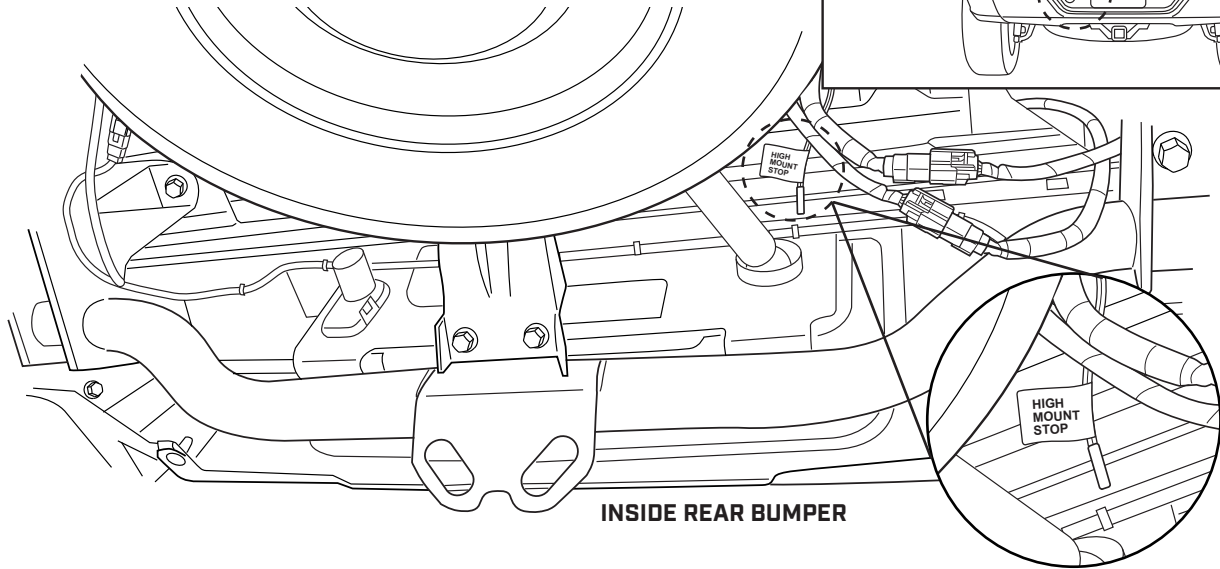
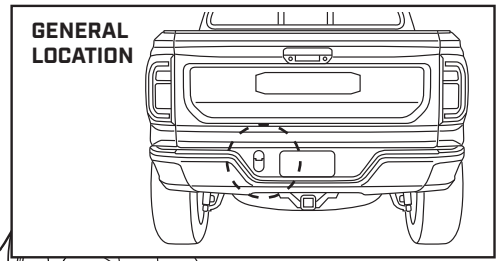

# STEP 58

USE WIRE STRIPPERS TO TRIM OFF THE END OF THE LAMP WIRE.

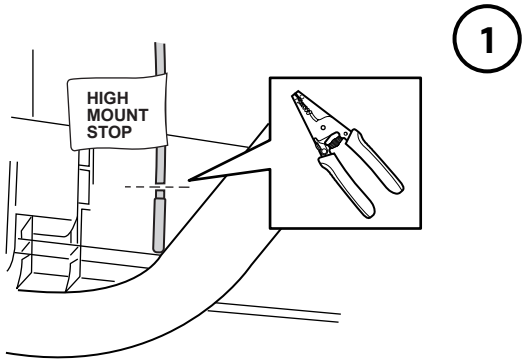

USE WIRE STRIPPERS TO REMOVE A HALF INCH OF PLASTIC WIRE INSULATION, EXPOSING THE COPPER WIRING WITHIN.

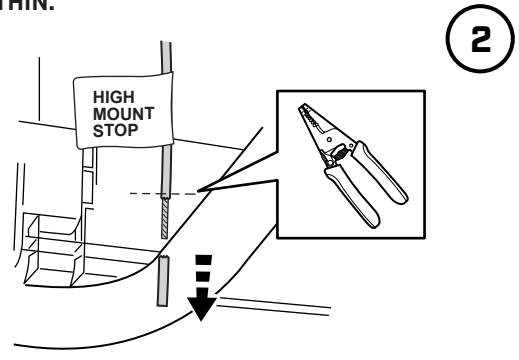

SLIDE THE STRIPPED END OF THE LAMP WIRE INTO ONE SIDE OF THE SPLICE TERMINAL.

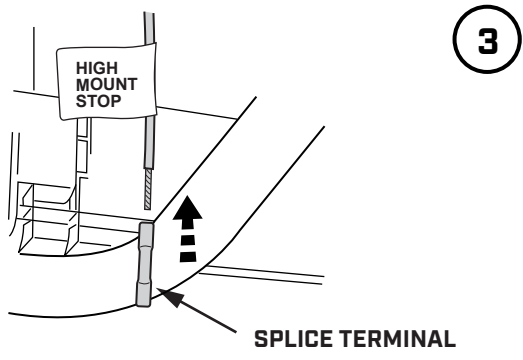

USE WIRE STRIPPERS TO APPLY FIRM PRESSURE TO THE SPLICE TERMINAL AT THE POINT WHERE THE WIRE ENTERS.

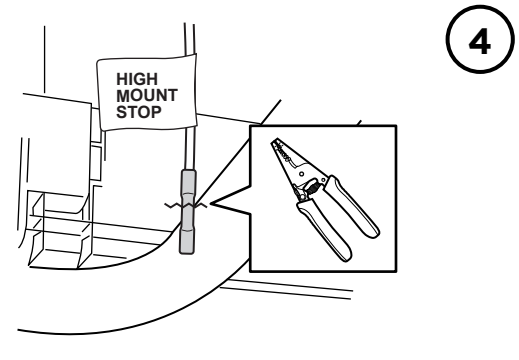

# STEP 59

LOCATE THE SUPPLIED CONNECTOR HARNESS.

USE THE WIRE STRIPPERS TO REMOVE A HALF INCH OF PLASTIC INSULATION FROM THE END OF THE BLUE WIRE

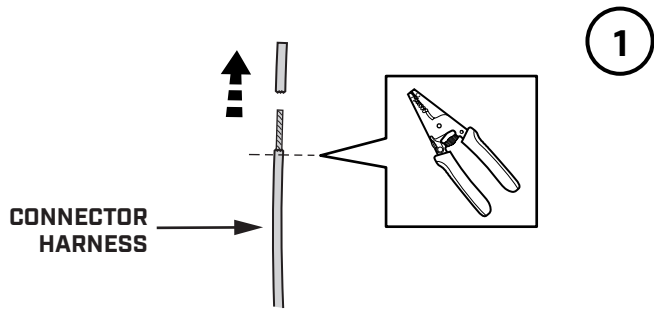

SLIDE THE STRIPPED END OF THE CONNECTOR HARNESS WIRE INTO THE OTHER SIDE OF THE SPLICE TERMINAL.

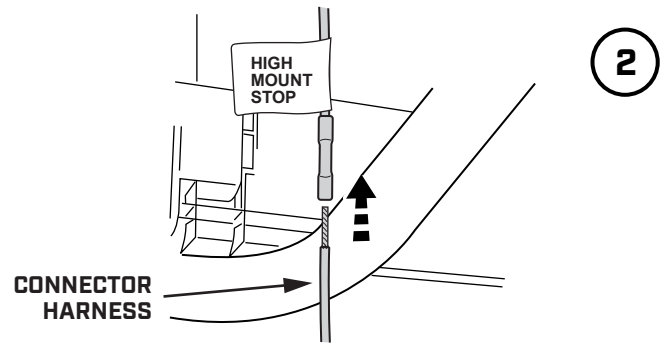

USE WIRE STRIPPERS TO APPLY FIRM PRESSURE TO THE SPLICE TERMINAL AT THE POINT WHERE THE WIRE ENTERS.

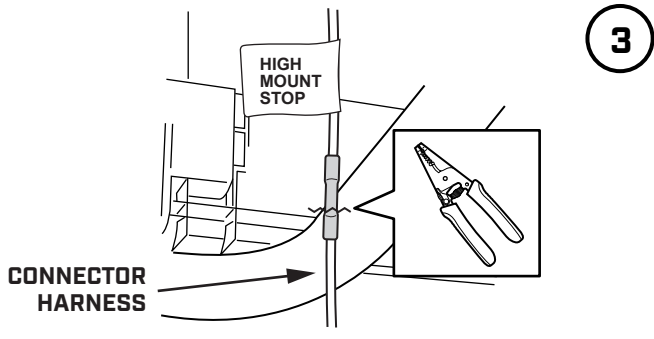

APPLY HEAT TO THE SPLICE TERMINAL TO SHRINK AND CONFORM TIGHTLY AROUND THE WIRES.

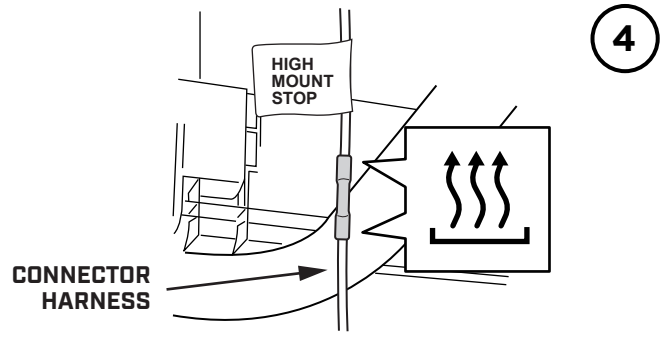

# STEP 60

SECURE THE GROUND WIRE ON THE CONNECTOR HARNESS TO THE CHASSIS AT A SUITABLE LOCATION UNDER THE VEHICLE.

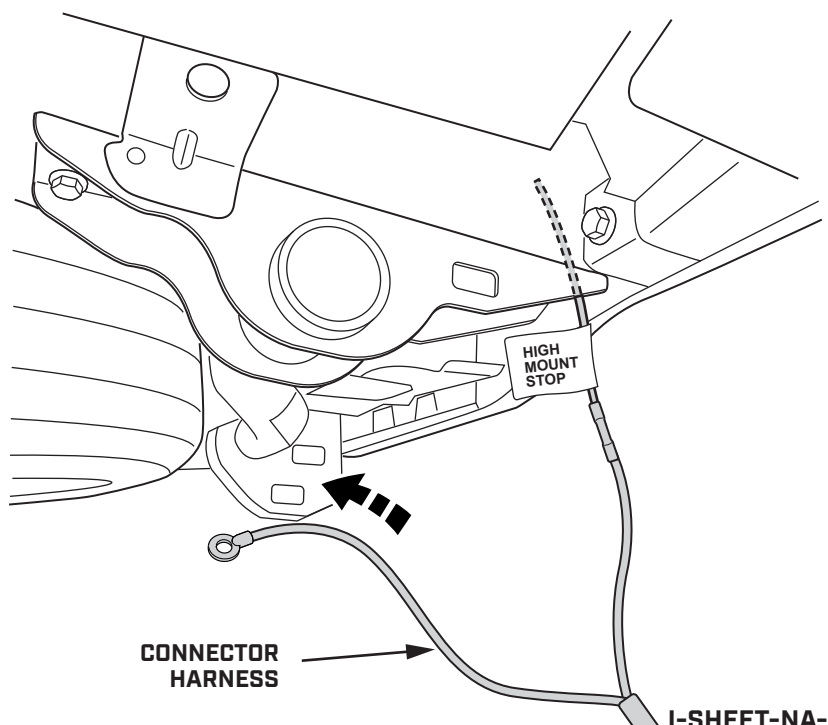
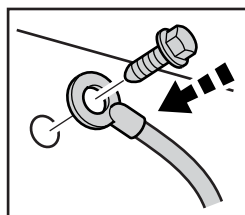

I-SHEET-NA-S3

## STEP 61

APPLY THE PLASTIC PROTECTIVE SHEATH ALONG THE ENTIRE LENGTH OF THE CONNECTOR HARNESS.

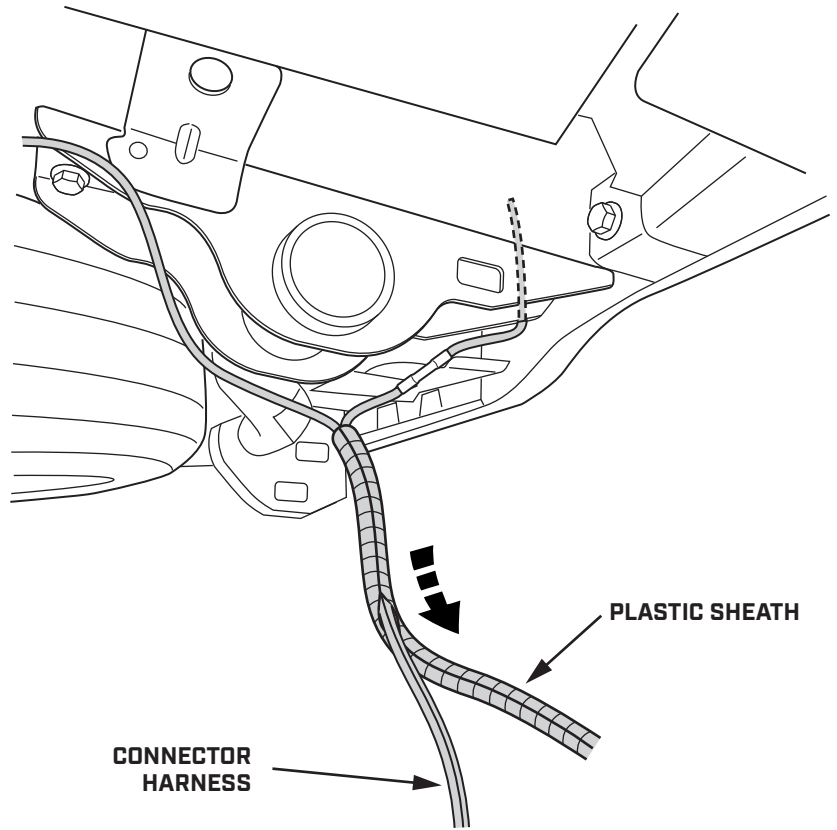

## STEP 62

REMOVE THE BOLTS HOLDING THE DRIVER SIDE TAILLIGHT ASSEMBLY

PLACE THE TAILLIGHT CAREFULLY ON THE TAILGATE. DO NOT UNPLUG ANY CONNECTORS

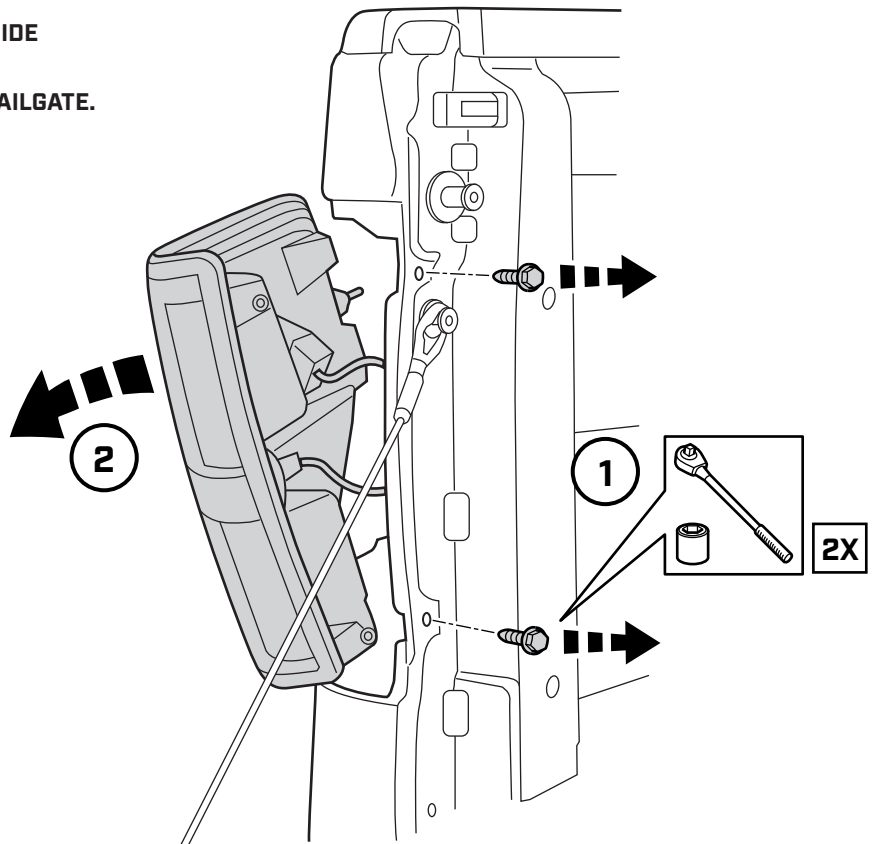

I-SHEET-NA-S3

## STEP 63

CAREFULLY PULL THE CONNECTOR HARNESS OUT THROUGH THE TAILLIGHT CAVITY.

ROUTE THE CONNECTOR HARNESS UP AND OUT THROUGH THE HOLE IN THE SIDE OF THE BED.

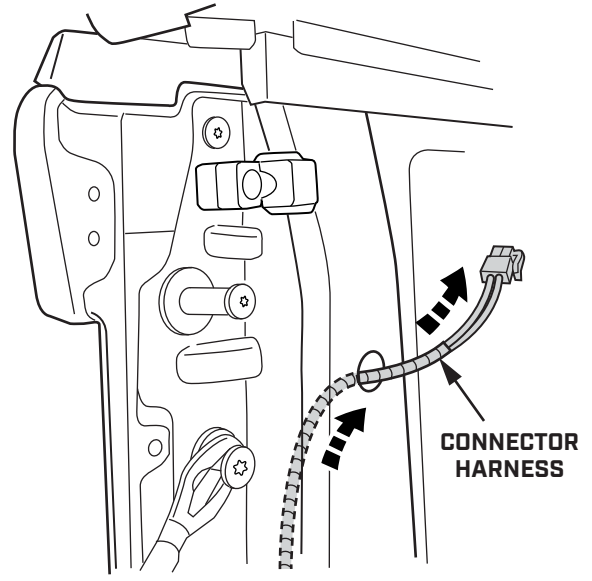
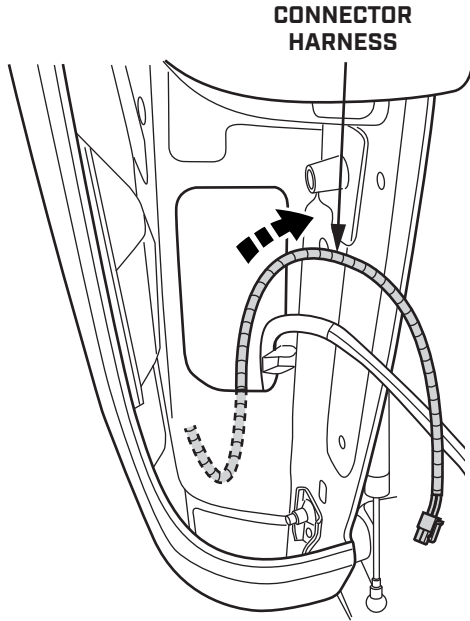

## STEP 64

LOCATE AND DISCONNECT THE THIRD BRAKE LIGHT EXTENSION HARNESS FROM THE INSIDE BACK LEFT CORNER OF THE SMARTCAP.

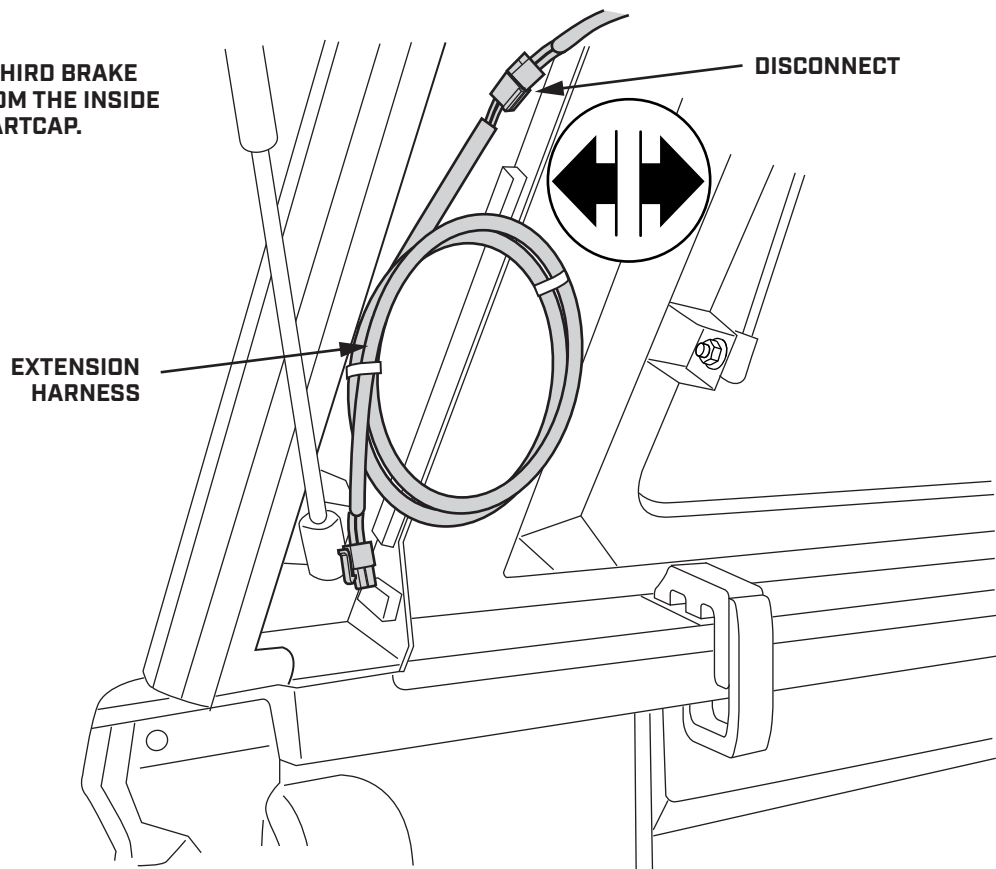

I-SHEET-NA-S3

## STEP 65

CONNECT THE 2-PIN PLUG FROM THE CONNECTOR HARNESS TO THE THIRD BRAKE LIGHT HARNESS.

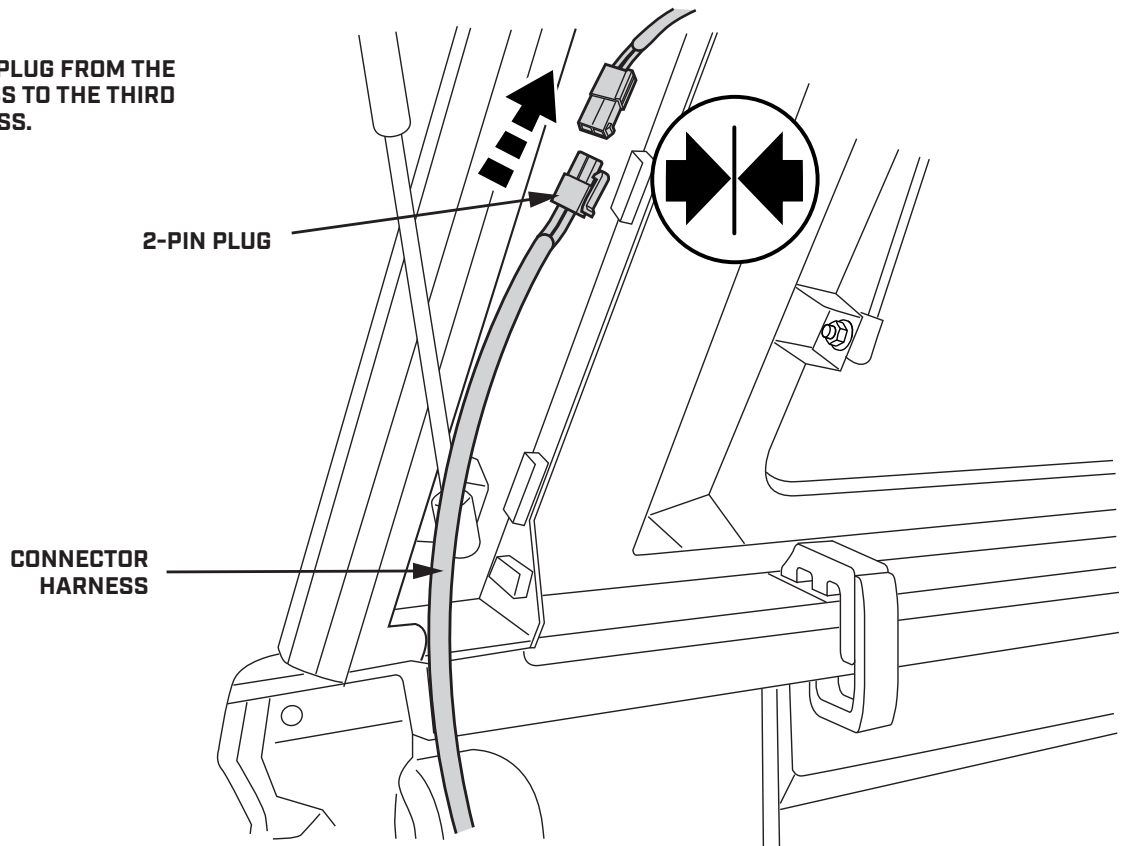

## STEP 66

REINSTALL THE TAILLIGHT ASSEMBLY.

BUNDLE EXTRA HARNESS LENGTH IN THE TAIL LIGHT CAVITY AND SECURE WITH A CABLE TIE.

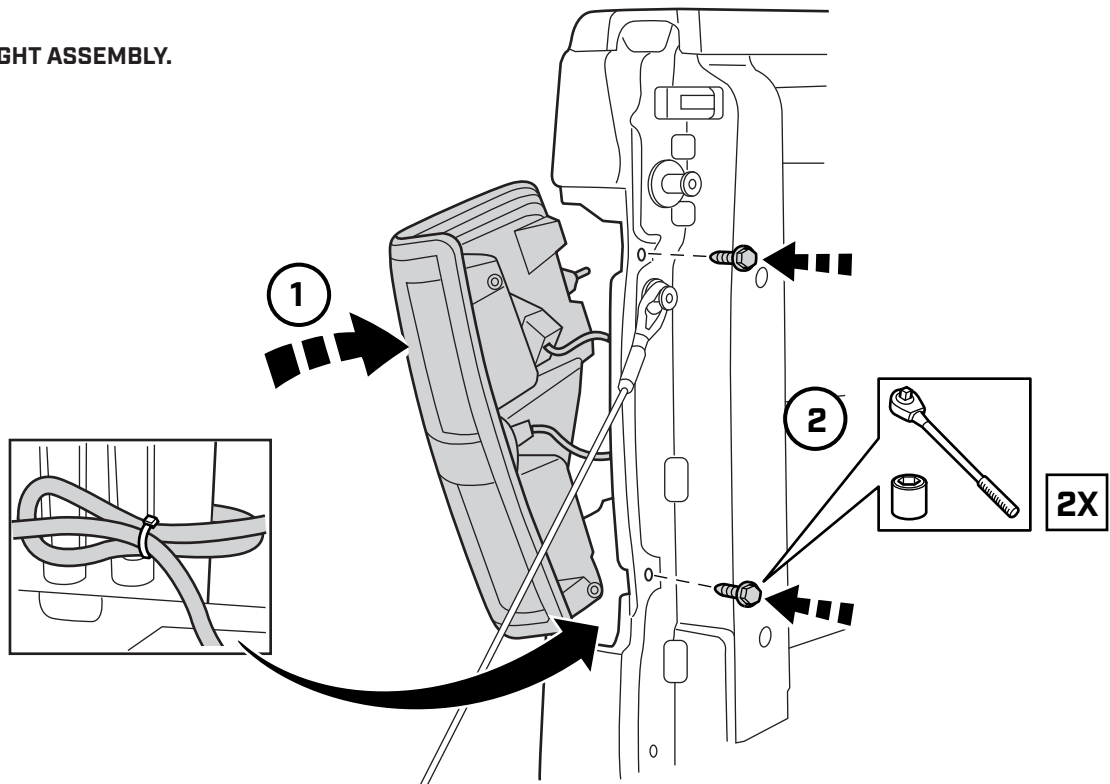

## STEP 67

SECURE LOOSE HANGING CONNECTOR HARNESS WIRES ALONG THE CHASSIS OF THE VEHICLE WITH CABLE TIES.

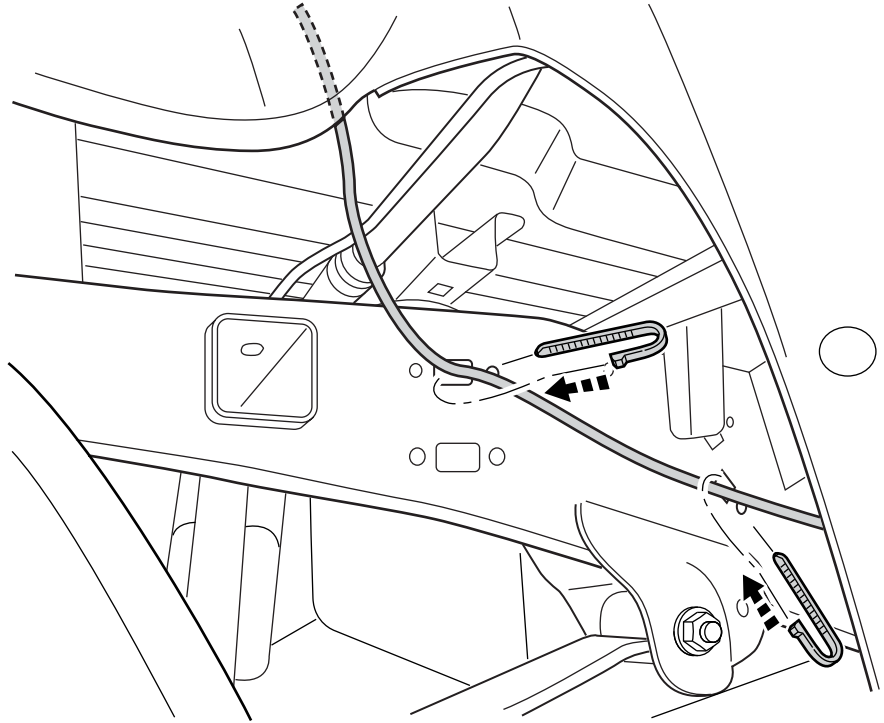

## STEP 68



### TEST YOUR BRAKE LIGHTS & TURN SIGNALS

- ▼ START THE TRUCK. SOME MODELS MAY TAKE UP TO 30 SECONDS FOR THE VEHICLE TO DETECT THE NEW CONNECTION.
- ▼ CHECK THE BRAKE LIGHTS AND TURN SIGNALS TO BE SURE THEY ARE FUNCTIONING PROPERLY.
- ▼ ONCE YOU HAVE CONFIRMED THAT THE LIGHTS ARE WORKING CORRECTLY, SECURE THE HARNESS WITH CABLE TIES.
- ▼ BE SURE NOT TO INTERFERE WITH ANY MOVING PARTS ON THE VEHICLE.

# SMARTCAP<sup>®</sup>

**THANKS FOR YOUR PURCHASE.  
PLEASE LET US KNOW IF YOU HAVE ANY QUESTIONS.**

**SMARTCAP.COM**

**SUPPORT.NA@SMARTCAP.COM - NORTH AMERICA**

**SUPPORT.SA@SMARTCAP.COM - REST OF WORLD**

